

FTB-2 and FTB-2 Pro



Copyright © 2014–2015 EXFO Inc. All rights reserved. No part of this publication may be reproduced, stored in a retrieval system or transmitted in any form, be it electronically, mechanically, or by any other means such as photocopying, recording or otherwise, without the prior written permission of EXFO Inc. (EXFO).

Information provided by EXFO is believed to be accurate and reliable. However, no responsibility is assumed by EXFO for its use nor for any infringements of patents or other rights of third parties that may result from its use. No license is granted by implication or otherwise under any patent rights of EXFO.

EXFO's Commerce And Government Entities (CAGE) code under the North Atlantic Treaty Organization (NATO) is 0L8C3.

The information contained in this publication is subject to change without notice.

Trademarks

EXFO's trademarks have been identified as such. However, the presence or absence of such identification does not affect the legal status of any trademark.

Units of Measurement

Units of measurement in this publication conform to SI standards and practices.

Patents

The design patent is pending for this product.

Version number: 1.0.9.2

Contents

Certification Information	viii
1 Introducing the FTB-2 and FTB-2 Pro	1
Main Features	1
Working With FTB and FTBx Modules	7
LED Indicators Description	10
Function Buttons Description	12
Power Sources	12
Automatic Fan Speed Management	14
Software Options for Your Unit	15
Product Registration	16
Conventions	17
2 Safety Information	19
Other Safety Symbols on Your Unit	20
Laser Safety Information	21
Electrical Safety Information	22

3 Getting Started with Your Unit	27
Grounding Your Unit	27
Positioning Your Unit	29
Installing the Carry Handle	30
Installing the Shoulder Strap	33
Installing or Removing FTB Module Adapters	34
Inserting and Removing Test Modules	39
Turning On Your Unit	49
Turning Off Your Unit	49
Configuring Your Unit At First Startup	55
Accessing and Exiting ToolBox X	57
Starting Module Applications	58
Using the On-Screen (Virtual) Keyboard	59
Working with Windows 8.1 Pro or Windows Embedded 8 Standard	60
Right-Clicking with the Touchscreen	62
Installing or Upgrading the Applications	63
Activating Software Options	66
Installing Third-Party Software on Your Unit	71
Protecting your Unit with an Antivirus Software	71
Securing your Unit Using the Kensington Lock	72
Using a Keyboard, Mouse or Other USB Devices	73
Working with Bluetooth Devices	75
4 Setting Up Your FTB-2 and FTB-2 Pro	77
Adjusting Brightness	77
Adjusting Microphone and Speaker Volume	78
Recalibrating the Touchscreen	83
Customizing the Right-Click Feature	86
Enabling or Disabling the Automatic Logon	90
Selecting the Startup Applications	94
Configuring Network Printers	96
Selecting the Language of Operation	98
Setting Date and Time Formats	109
Adjusting the Date, Time and Time Zone	111
Configuring the Power Management Options	112
Setting ToolBox X Behavior	112
Configuring the Internet Options	124
Configuring Parameters via Windows Mobility Center	127
Setting Other Parameters	128

5 Working with Your Unit	129
Printing Documents	129
Viewing PDF Files	130
Taking Screen Captures	131
Browsing the Web	132
Accessing the Internet with a 3G USB Modem Key	133
Managing Favorites	135
Using the Calculator	143
Using the Text Editor	143
Accessing Other Tools	144
6 Using the Optional Built-In Power Meter and VFL	145
7 Inspecting Fibers with a Probe	147
8 Managing Data	149
Viewing Disk Space and Managing Files	150
Transferring Data via Bluetooth	151
Connecting to a Wireless Network	160
Using the USB to RS-232 Adapter	162
Freeing Up Disk Space with the Disk Cleanup Utility	168
Enabling or Disabling the Wireless Communication	172
Connecting to a VPN from Your Unit	176
9 Accessing Your Unit Remotely	185
Working with Remote Desktop	186
Working With TightVNC	196
Adding Exceptions to the Firewall	203
10 Testing Network Connections	207
Performing a Ping Test	207
Performing a Trace Route Test	210
Exporting the Results	212
11 Preparing for Automation	213
Linking Units with the Ethernet Port	215
Linking Units Using a Serial Port	215
Getting Optimum Performance from Your Unit	216
Changing Communication Settings	218
Configuring DCOM Access to Your Unit	222
Preparing to Control Modules with a Dedicated Application	246

12 Using Your Unit and Modules in an Automated Test Environment	251
Standard Status Data Structure	252
SCPI Command Structure	256
Consulting Data Types	259
Writing Remote Control Code	260
Error Message Format	262
Monitoring Remote Commands	263
13 Maintenance	267
Cleaning Detector Ports	268
Cleaning VFL-Type Connectors	269
Cleaning the Touchscreen	270
Recharging the Batteries	271
Replacing Batteries	274
Installing or Removing the Power Meter and VFL	279
Managing Windows Updates	286
Recycling and Disposal (Applies to European Union Only)	288
14 Troubleshooting	289
Solving Common Problems	289
Restoring Your Unit to Normal Operation	294
Accessing the Online Documentation	313
Contacting the Technical Support Group	314
Viewing System Information	315
Retrieving Network Interfaces Information	318
Transportation	322
15 Warranty	323
General Information	323
Liability	324
Exclusions	324
Certification	324
Service and Repairs	325
EXFO Service Centers Worldwide	326
A Technical Specifications	327
B Data Types	329
Applicable Data Types for Input—IEEE 488.2	330
Applicable Data Types for Output —IEEE 488.2	339
Applicable Data Types for Input—SCPI	349
Special Numeric Values Received on Output	350

C IEEE 488.2 and Specific Command Reference	351
IEEE 488.2 Commands—Quick Reference	351
IEEE 488.2 Required Commands	352
Specific Commands—Quick Reference	372
Specific Commands	373
D SCPI-Based Errors	391
E COM Properties and Events	407
ActiveX (COM/DCOM)—Quick Reference	408
Properties	409
Events	416
F Communicating Through TCP/IP over Telnet	417
Introducing TCP/IP over Telnet	417
Features	418
Activating TCP/IP over Telnet	419
Executing SCPI Commands Over Telnet	420
Releasing Modules	426
Internal Commands of the TCP/IP over Telnet Protocol	427
Index	435

Certification Information

North America Regulatory Statement

This unit was certified by an agency approved in both Canada and the United States of America. It has been evaluated according to applicable North American approved standards for product safety for use in Canada and the United States.

Electronic test and measurement equipment is exempt from FCC part 15, subpart B compliance in the United States of America and from ICES-003 compliance in Canada. However, EXFO Inc. makes reasonable efforts to ensure compliance to the applicable standards.

The limits set by these standards are designed to provide reasonable protection against harmful interference when the equipment is operated in a commercial environment. This equipment generates, uses, and can radiate radio frequency energy and, if not installed and used in accordance with the user guide, may cause harmful interference to radio communications. Operation of this equipment in a residential area is likely to cause harmful interference in which case the user will be required to correct the interference at his own expense.

Modifications not expressly approved by the manufacturer could void the user's authority to operate the equipment.

Your unit comes with an internal wireless module and antenna for which the following information applies:

- This equipment has been tested and found to comply with the limits for a Class A digital device, pursuant to Part 15 of the FCC Rules. Operation is subject to the following two conditions: (1) This device may not cause harmful interference, and (2) this device must accept any interference received, including interference that may cause undesired operation.
- This device complies with Industry Canada license-exempt RSS standard(s). Operation is subject to the following two conditions: (1) this device may not cause interference, and (2) this device must accept any interference, including interference that may cause undesired operation of the device.
- This device complies with the US/Canada portable RF exposure limit set forth for an uncontrolled environment and is safe for intended operation as described in this user documentation. The further RF exposure reduction can be achieved if the device can be kept as far as possible from the user's body.
- This device does not contain any user-serviceable components. Any unauthorized product changes or modifications will invalidate warranty and all applicable regulatory certifications and approvals.

Note: *You will only be able to work with Wi-Fi and Bluetooth if you have purchased the corresponding option.*

European Community Declaration of Conformity

Warning: This is a class A product. In a domestic environment, this product may cause radio interference in which case the user may be required to take adequate measures.

Hereby, EXFO declares that the radio equipment type “Wide Band Data Transmission” is in compliance with Directive 2014/53/EU.

An electronic version of the complete declaration of conformity for your product is available on our website at www.exfo.com. Refer to the product’s page on the Web site for details.

The information about the Bluetooth and Wi-Fi frequency bands is as follows:

- Bluetooth: Between the frequencies 2400.0 MHz - 2483.5 MHz.
The output power is 2.0 dBm typical.
- Wi-Fi: Between the frequencies 2400.0 MHz - 2483.5 MHz.
The maximum output power is 17 dBm.

1 Introducing the FTB-2 and FTB-2 Pro

Note: *In this documentation, the words “tap” and “double-tap” (related to the use of a touchscreen) replace the words “click” and “double-click”.*

Note: *Many of the illustrations referring to Windows features were made using Windows 8.1 Pro. For this reason, depending on the model that you have purchased, the appearance of the applications may vary slightly from the illustrations presented in this documentation.*

Main Features

Your unit includes the following:

- 10.1-inch color touchscreen (LCD and touchscreen optimized for outdoor use available as an option)
- Two USB 2.0 host ports and one USB 3.0 host port
- Ethernet port (10/100/1000 Base-T)
- Headset/microphone port (for headsets equipped with a microphone)
- External monitor port (for monitors with DisplayPort interface)
- Optional Wi-Fi and Bluetooth capability
- Optional built-in power meter and VFL
- Windows 8.1 Pro (FTB-2 Pro)/ Windows Embedded 8 Standard (FTB-2) operating system
- Multitasking possibilities
- Remote access to your unit (via TightVNC or Remote Desktop)
- Modules and instruments can be controlled locally via the ToolBox X software or remotely through RS-232 or Ethernet TCP/IP (using SCPI commands).
- Direct Web access from your unit
- Possibility to take screen captures

Introducing the FTB-2 and FTB-2 Pro

Main Features

- PDF file viewer available from your unit
- Easy transfer of files and folders to an external storage device
- Easy software updates

Front

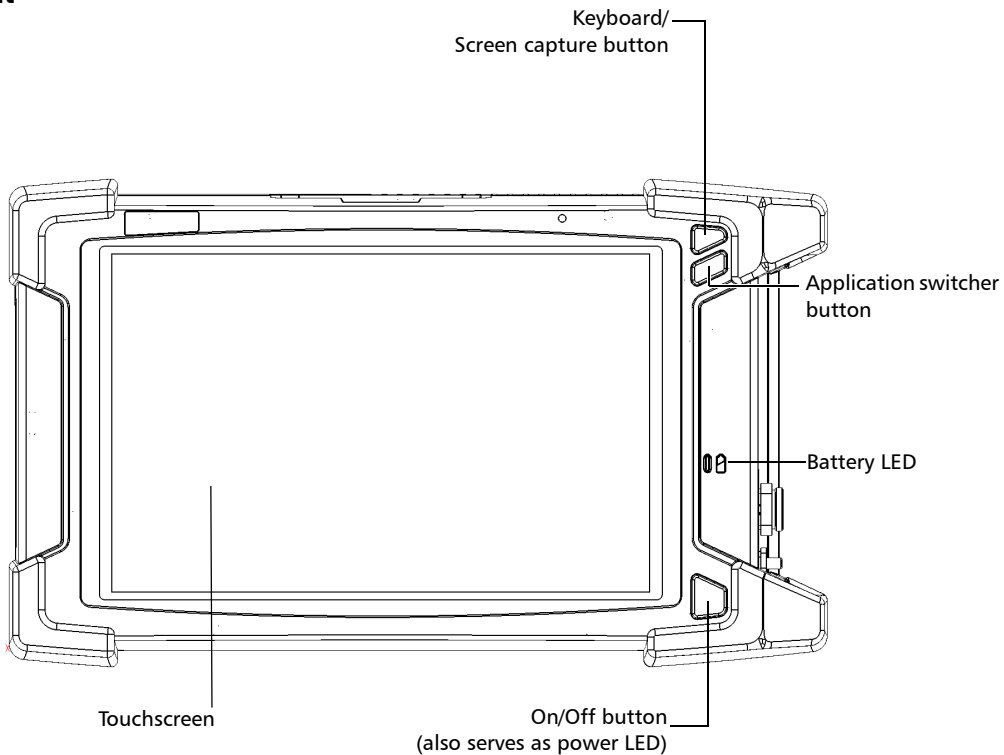

Right panel

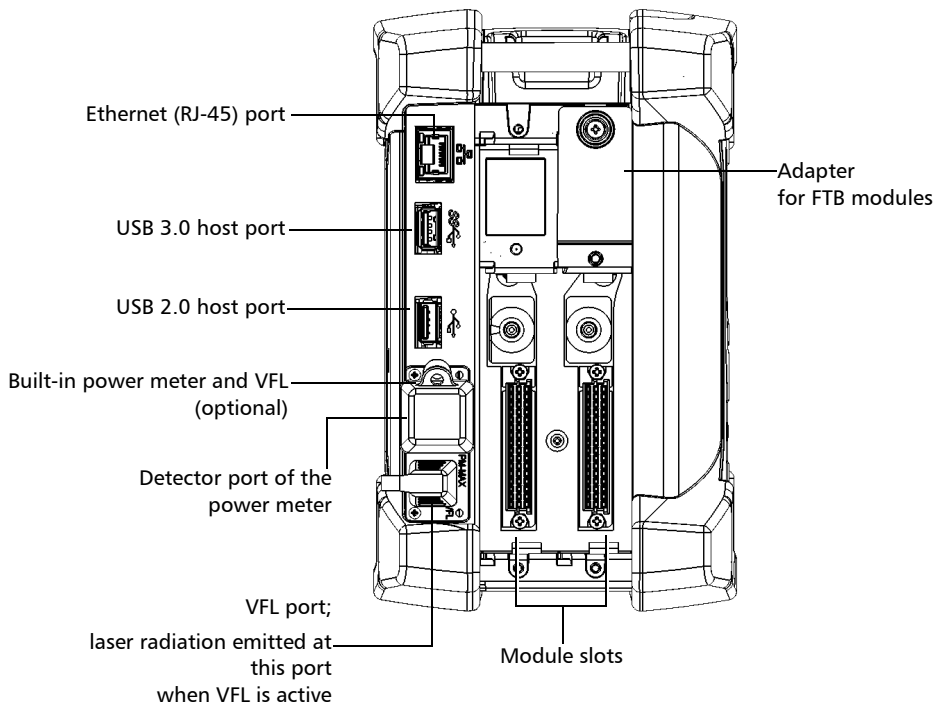

Introducing the FTB-2 and FTB-2 Pro

Main Features

Left panel

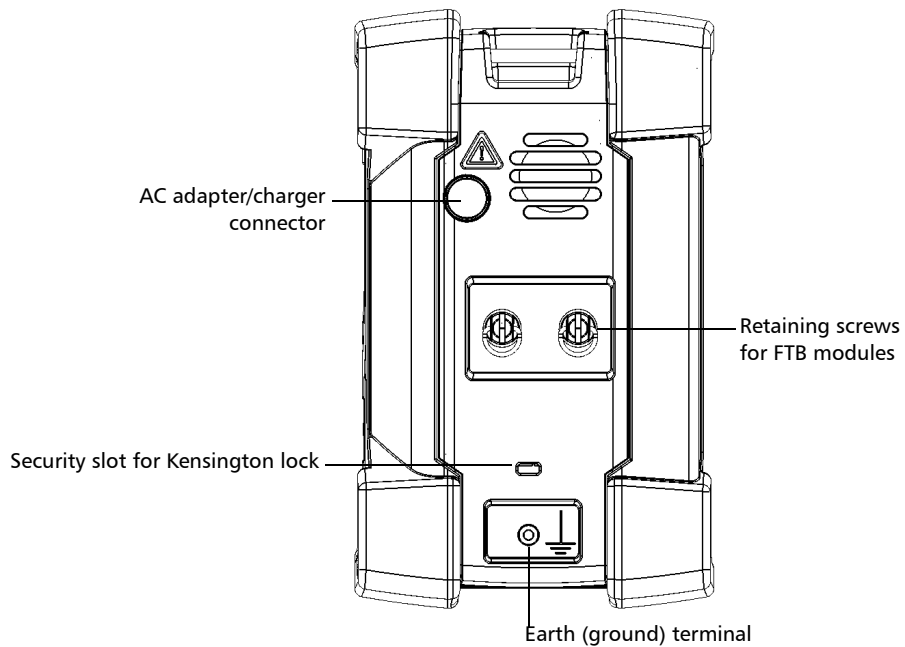

Top

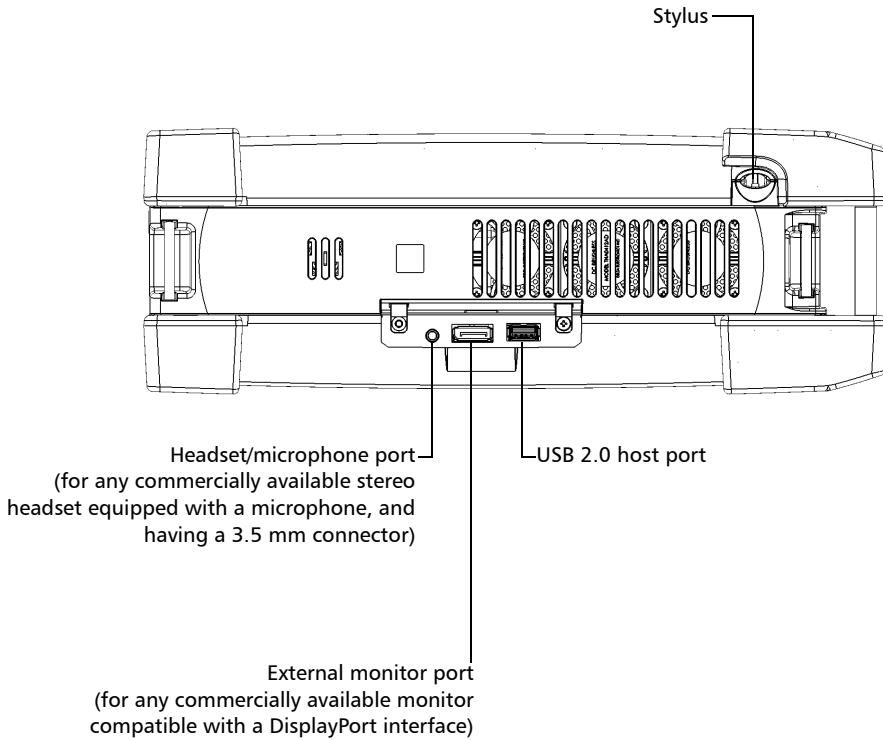

Introducing the FTB-2 and FTB-2 Pro

Main Features

Back

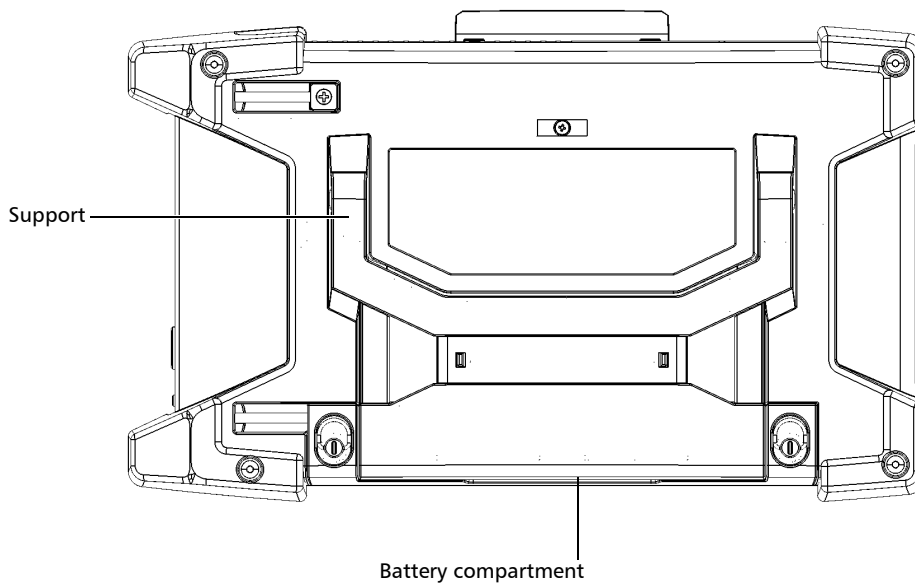

Working With FTB and FTBx Modules

You can insert FTBx modules, FTB modules, or a combination of both in your unit.



CAUTION

Your unit is compatible with some of the FTBx modules and some of the FTB modules. For a list of supported modules, refer to your unit's technical specifications. To avoid damaging your unit, use it only with modules approved by EXFO.

The type of modules (FTBx or FTB) is indicated both on the front panel of the module and on the identification sticker affixed to its side. However, since the two types of modules have very different heights and lengths, you can also identify them just at a glance.

On the images below, the FTBx module is shown in dark gray.

Side

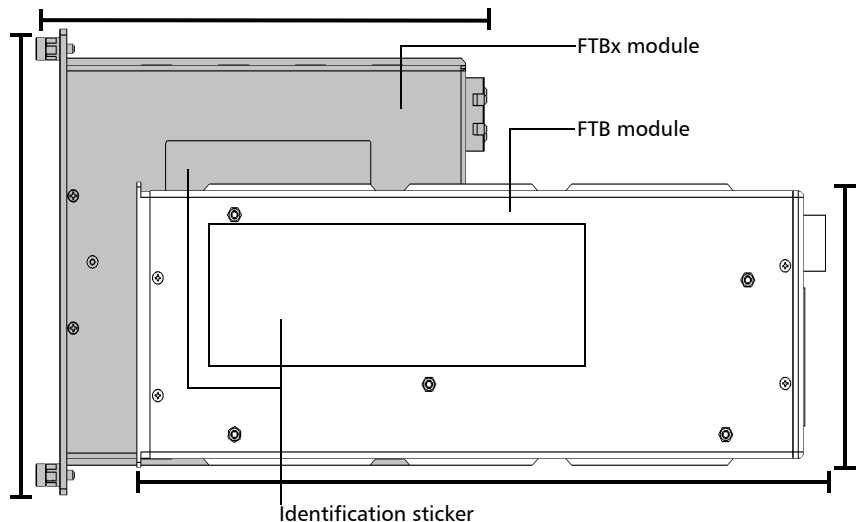

Introducing the FTB-2 and FTB-2 Pro

Working With FTB and FTBx Modules

Front

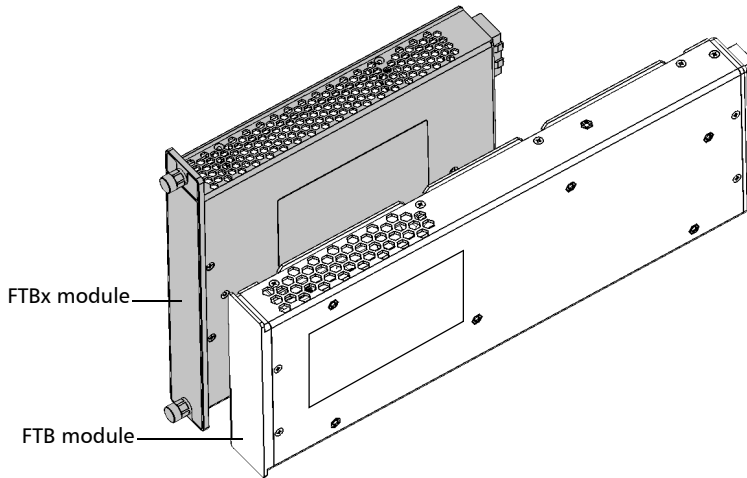

Back

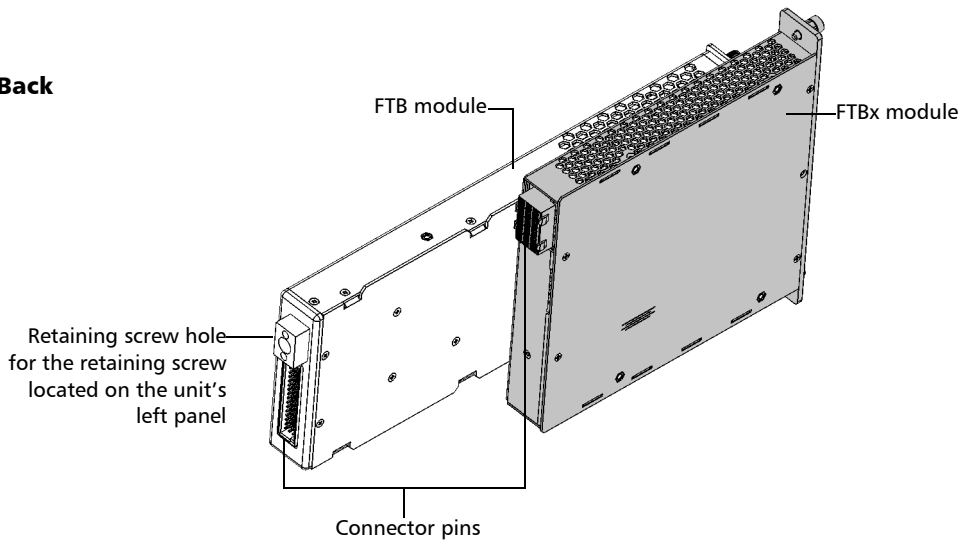

Introducing the FTB-2 and FTB-2 Pro

Working With FTB and FTBx Modules

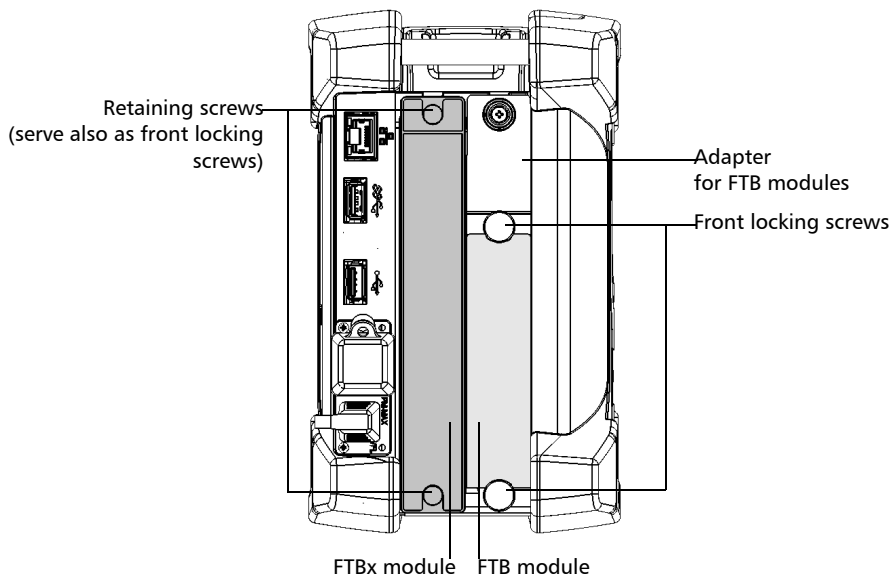

Because the two types of modules have different sizes, you need a module adapter to work with FTB modules if your unit is not already equipped with such adapters. The adapters must be removed before inserting FTBx modules.



For more information on how to install or remove the adapters, see *Installing or Removing FTB Module Adapters* on page 34. For more information on how to insert or remove modules, see *Inserting and Removing Test Modules* on page 39.

LED Indicators Description

There are two LED indicators located on the front panel of your unit, providing you with information about the power and battery statuses.

LED	Status	Meaning
	Green	Unit is on.
	Green, blinking	Unit is in Sleep mode.
	Off	Unit is off or in Hibernation mode.
	Red	There is a major hardware problem with the unit. Contact EXFO.
 (when unit is connected to an external power source)	Green	All batteries are fully charged.
	Green, blinking	At least one battery is charging.
	Yellow, blinking	The unit and its modules would be using more power than what is available from the batteries. Do not disconnect AC power while this module is in use. A blinking yellow LED takes precedence over a blinking green one, so when AC power is connected, even if the LED is blinking yellow, batteries are probably charging (depending on conditions).
	Red	Battery error. Contact EXFO.
	Red, blinking	The detected temperature is too high. This could lead to a thermal shutdown of the unit if no action is taken to reduce the temperature.
	Off	No battery present in the unit.

LED	Status	Meaning
 (when unit is not connected to an external power source)	Off	The global level of the batteries is above the “low-battery threshold”.
	Yellow	The global level of batteries is low.
	Yellow, blinking	The unit and its modules would be using more power than what is available from the batteries. Connect AC power as soon as possible.
	Red, blinking	The detected temperature is too high. This could lead to a thermal shutdown of the unit if no action is taken to reduce the temperature.



Introducing the FTB-2 and FTB-2 Pro

Function Buttons Description

Function Buttons Description

Your unit is equipped with function buttons that give you access to features at all times.

The table below shows an overview of their purpose.

Button	Meaning
	<ul style="list-style-type: none">▶ Displays the on-screen keyboard. Press once to show the keyboard. Press once again to hide it.▶ Takes a screen capture. Hold down for a few seconds.
	<p>Enables you to switch from one task to another. It is the equivalent of pressing the ALT + TAB key combination on a hardware keyboard.</p> <ul style="list-style-type: none">▶ Press once to view the list of running applications.▶ Press as many times as needed to select the desired application.
	<p>Turns your unit on and off.</p> <p>Press for one second to turn the unit on.</p> <p>For more information on the various ways to turn off your unit, see <i>Turning Off Your Unit</i> on page 49.</p>

Power Sources

Your unit operates with the following power sources:

- ▶ AC adapter/charger (connected to standard power outlet—indoor use only).

When it is connected to an external power source with the AC adapter/charger, the unit will function even if the batteries are not present.

- Lithium-ion rechargeable batteries (automatically take over if you disconnect the unit from its external power source). The number of batteries that power your unit and that come with it depends on the model that you have purchased. The table below gives detailed information.

Model	Number of batteries that power the unit	Number of batteries provided with the unit
FTB-2	1 Battery must be inserted in the first battery slot (use the markings at the back of the unit to guide you). The second battery slot does not power the unit. It only serves as storage for an extra battery that you would swap in the first battery slot when required.	1 You can purchase an extra battery and store it in the second battery slot.
FTB-2 Pro	2	2

- Possible to switch from an external power source to battery power or vice versa without affecting operation.
- The battery recharges automatically when the unit is connected to an external power source (with the AC adapter/charger).

Note: *When the ambient temperature is below 0 °C (32 °F) or when it reaches or exceeds about 40 °C, the batteries can either charge more slowly than usual, or not charge at all, depending on the internal temperature of your unit.*

For more information, see *Electrical Safety Information* on page 22.

Introducing the FTB-2 and FTB-2 Pro

Automatic Fan Speed Management

Automatic Fan Speed Management

Your unit will determine the most appropriate fan speed, depending on the power requirements and the type of modules you are using.



IMPORTANT

Fan speed is always determined to cool down the most heat-generating modules.



CAUTION

Make sure to use protective covers over empty slots of your unit to avoid overheating.

Software Options for Your Unit

The following software options are offered for the platform itself.

Name of the Option	Description	Comments
IPT	Enables you to perform <i>ping</i> and <i>trace route</i> tests.	Available for FTB-2 and FTB-2 Pro units.
RF	Enables you to work with Wi-Fi and Bluetooth.	Option for the FTB-2 Pro units only. The Wi-Fi and Bluetooth option is a hardware option for the FTB-2 units.
Automation	Enables you to perform automation tasks and use your unit in an automated test environment.	Option for the FTB-2 units only. The automation features are part of the applications delivered with the FTB-2 Pro units.

For more information on how to activate software options for your unit, see *Activating Software Options* on page 66.

For more information on the software options available for modules, test instruments, or dedicated applications, refer to the user documentation that comes with these products.

Product Registration

You can now register your new EXFO products either online or directly from your unit (if it is connected to the Internet), and benefit from every possible opportunity to optimize their performance. By doing so, you will always be notified of the latest software updates, key product enhancements and up-to-date support information related to your products.

To register your product directly from your unit:

1. Ensure that your unit can access the Internet.
2. From ToolBox X, tap **Utilities**, and then **Product Registration**.
3. Follow the on-screen instructions.

To register your product online:

1. Open a Web browser and go to www.exfo.com.
2. Log in to your EXFO account.
3. Tap **Support**.
4. Under **Tools**, tap **Manage My Products**.
5. Tap **Register**.
6. Follow the on-screen instructions.

Conventions

Before using the product described in this guide, you should understand the following conventions:



WARNING

Indicates a potentially hazardous situation which, if not avoided, could result in *death or serious injury*. Do not proceed unless you understand and meet the required conditions.



CAUTION

Indicates a potentially hazardous situation which, if not avoided, may result in *minor or moderate injury*. Do not proceed unless you understand and meet the required conditions.



CAUTION

Indicates a potentially hazardous situation which, if not avoided, may result in *component damage*. Do not proceed unless you understand and meet the required conditions.



IMPORTANT

Refers to information about this product you should not overlook.

2 **Safety Information**



WARNING

Do not install or terminate fibers while a light source is active. Never look directly into a live fiber and ensure that your eyes are protected at all times.



WARNING

The use of controls, adjustments and procedures, namely for operation and maintenance, other than those specified herein may result in hazardous radiation exposure or impair the protection provided by this unit.



IMPORTANT

When you see the following symbol on your unit , make sure that you refer to the instructions provided in your user documentation. Ensure that you understand and meet the required conditions before using your product.



IMPORTANT











Other safety instructions relevant for your product are located throughout this documentation, depending on the action to perform. Make sure to read them carefully when they apply to your situation.

Safety Information

Other Safety Symbols on Your Unit

Other Safety Symbols on Your Unit

One or more of the following symbols may also appear on your unit.

Symbol	Meaning
	Direct current
	Alternating current
	The unit is equipped with an earth (ground) terminal.
	The unit is equipped with a protective conductor terminal.
	The unit is equipped with a frame or chassis terminal.
	On (Power)
	Off (Power)
 OR 	On/Off (Power)
	Fuse

Laser Safety Information

Units with a Built-In VFL

Your instrument is a Class 2 laser product in compliance with standards IEC 60825-1: 2007 and 21 CFR 1040.10, except for deviations pursuant to Laser Notice No. 50, dated June 24, 2007. Laser radiation is emitted at the output port.

The following label(s) indicate that the product contains a Class 2 source:



Affixed to back panel of unit.

The VFL laser is active when the  symbol is displayed in the power meter and VFL application.

The modules that you use with your unit may have different laser classes. Refer to the user guide or the online help of the different modules for the exact information.

Units without a Built-In VFL

If your unit is not equipped with a VFL, the laser class of your unit depends on the modules that you use. Refer to the user guide or the online help of the different modules for the exact information.

Safety Information

Electrical Safety Information

Electrical Safety Information

If you need to ensure that the unit is completely turned off, disconnect the power cable and remove the batteries. For more information on how to remove the batteries, see the section about replacing the batteries in this user documentation.



WARNING

- Insert the power cable plug into a power outlet with a protective ground contact. Do not use an extension cord without a protective conductor.
- Before turning on the unit, connect all grounding terminals and extension cords to a protective ground via a ground socket. Any interruption of the protective grounding is a potential shock hazard and may cause personal injury. Whenever the ground protection is impaired, do not use the unit and secure it against any accidental operation.
- Do not tamper with the protective ground terminal.



WARNING

- Never connect the unit to the AC mains (with the adapter/charger) when it is used outdoors.
- Position the unit so that the air can circulate freely around it.
- Operation of any electrical instrument around flammable gases or fumes constitutes a major safety hazard.
- To avoid electrical shock, do not operate the unit if any part of the outer surface (covers, panels, etc.) is damaged.
- Only authorized personnel should carry out adjustments, maintenance or repair of opened units under voltage. A person qualified in first aid must also be present. Do not replace any components while the power cable and batteries are connected.
- Unless otherwise specified, all interfaces are intended for connection to Safety Extra Low Voltage (SELV) circuits only.
- Capacitors inside the unit may be charged even if the unit has been disconnected from its electrical supply.

Safety Information

Electrical Safety Information



WARNING

- Use only the listed and certified AC adapter/charger provided by EXFO with your unit. It provides reinforced insulation between primary and secondary, and is suitably rated for the country where the unit is sold.
- Use only accessories (such as the batteries and fiber inspection probe) designed for your unit and approved by EXFO. For a complete list of accessories available for your unit, refer to its technical specifications.
- When you use the unit outdoors, ensure that it is protected from liquids, dust, direct sunlight, precipitation, and full wind pressure.

Equipment Ratings	
Temperature	
➤ Operation	<ul style="list-style-type: none">➤ unit powered by batteries: 0 °C to 50 °C (32 °F to 122 °F)^{a,b}➤ unit connected to AC adapter : 0 °C to 40 °C (32 °F to 104 °F)
➤ Storage	<ul style="list-style-type: none">➤ unit without batteries: -40 °C to 70 °C (-40 °F to 158 °F)➤ unit with batteries: -20 °C to 60 °C (-4 °F to 140 °F)
Relative humidity ^c	<ul style="list-style-type: none">➤ unit: ≤ 95 % non-condensing➤ AC adapter: 10 % to 80 % non-condensing
Maximum operation altitude	<ul style="list-style-type: none">➤ 2000 m (6562 ft) (unit connected to external power supply)➤ 5000 m (16405 ft) (unit operated from batteries)
Pollution degree	<ul style="list-style-type: none">➤ 2 (unit connected to external power supply)➤ 3 (unit operated from batteries)^d

Equipment Ratings	
Overvoltage category	<ul style="list-style-type: none"> ➤ unit: I ➤ AC adapter: II
Measurement category	Not rated for measurement categories II, III, or IV
Input power ^e	<ul style="list-style-type: none"> ➤ unit (FTB-2): --- 24 V; 3.75 A ➤ unit (FTB-2 Pro): --- 24 V; 8.33 A ➤ AC adapter: ~ 100 - 240 V; 50/60 Hz; 4 A

- a. When the unit is used at an altitude of 5000 m, the maximum operating temperature is 32 °C (89.6 °F)
- b. Operating time is dependent upon power consumption and temperature. If the unit is used at maximum power and maximum temperature, it will power off automatically any time after 10 minutes for safety reasons.
- c. Measured in 0 °C to 31 °C (32 °F to 87.8 °F) range, decreasing linearly to 50 % at 40 °C (104 °F).
- d. Equipment must be normally protected against exposure to direct sunlight, precipitation and full wind pressure.
- e. Not exceeding $\pm 10\%$ of the nominal voltage.



CAUTION

The use of voltages higher than those indicated on the label affixed to your unit may damage the unit.



CAUTION

The operation and storage temperatures, as well as the altitude and relative humidity values of some modules may differ from those specified for your platform. In this case, always ensure that you comply with the most restrictive conditions (either module or platform).

3 Getting Started with Your Unit

Grounding Your Unit

When you perform outside plant tests with certain modules, you may want to ground your unit because it can be exposed to overvoltages from the telecommunication network. Refer to the user documentation that comes with your modules to know if you need to ground your unit.



WARNING

- Not grounding your unit when it is recommended may cause serious injuries to communication network staff or other users.
- Ensure to ground the unit using a grounding method that complies with your local regulations. If you are not sure on how to proceed, consult a certified electrician.

Note: *To ground your unit, you need a grounding wire (18 AWG minimum) with a U-shaped terminal.*

Getting Started with Your Unit

Grounding Your Unit

To ground your unit:

1. Position the unit so that you can see its left panel.
2. Place the U-shaped terminal under the grounding stud's screw head.

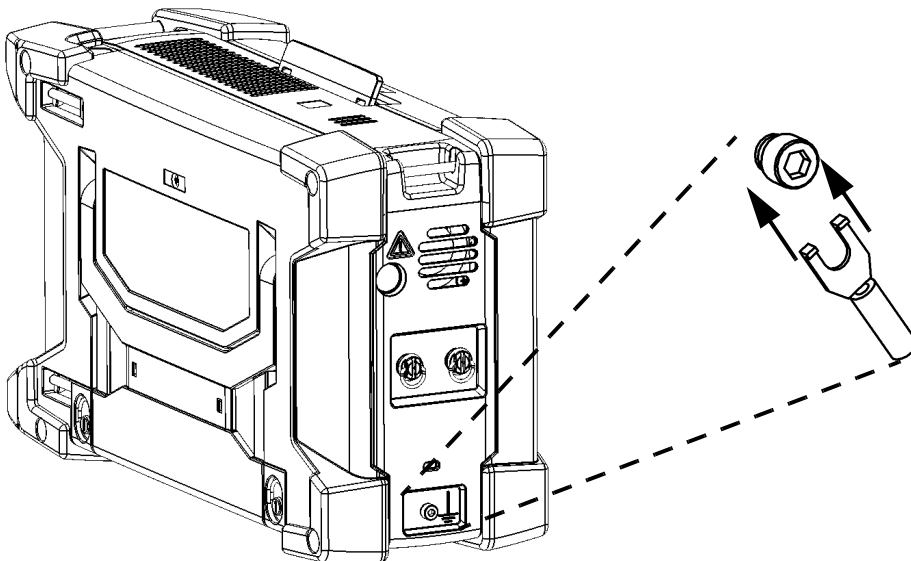

3. Turn the grounding stud clockwise to screw it tight.
 4. Ground the other end of the wire as per your local regulation.
- Your unit is now grounded properly.

Positioning Your Unit

You can position your unit either vertically (with the screen facing you), or at an angle, using the support on the back panel. You can also hold your unit with the provided hand strap.

Note: *The stand ensures optimum stability to the unit during your tests.*

To position the unit using the support:

Pull out the support.

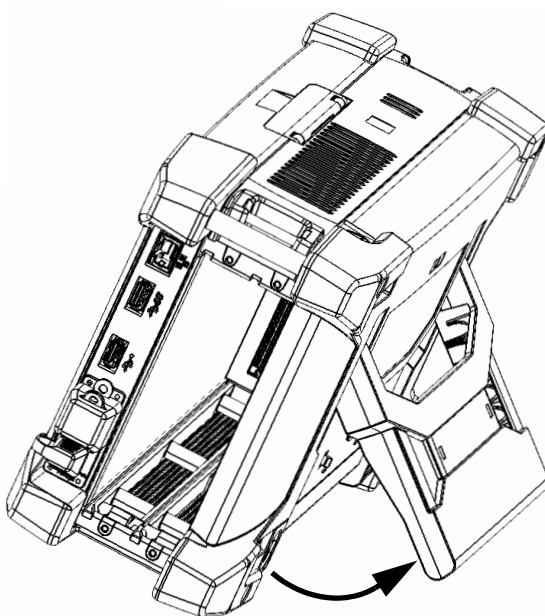

Getting Started with Your Unit

Installing the Carry Handle

Installing the Carry Handle

In addition to the hand strap, you can install a carry handle on your unit.

Note: *If you wish to use a shoulder strap (sold separately by EXFO), you must first install the carry handle.*

To install the carry handle:

1. Position the unit so that its front panel is facing you, and that you can see its top panel.

Top panel



2. Ensure that both ends of the carry handle are fully extended.

Getting Started with Your Unit

Installing the Carry Handle

3. Place the handle flat on the top of your unit as shown below.



4. Slide each end of the handle *under* the corresponding metal rod.
5. Pull on the straps until the base of each D-shaped metal ring rests on the corresponding rod.



6. Slide the straps through the D-shaped rings.



Getting Started with Your Unit

Installing the Carry Handle

7. Fold the Velcro straps towards the center. Both ends should meet without any gap.



8. Fold the large part of the handle over the straps, and secure it in place with the Velcro.



You are now ready to use the carry handle, or to attach a shoulder strap (see *Installing the Shoulder Strap* on page 33).

Installing the Shoulder Strap

Your unit comes with a hand strap and a carry handle, but you can also install an optional shoulder strap for more versatility.



CAUTION

Always attach the snap hooks of the shoulder strap to the D-shaped metal rings of the carry handle. Attaching the shoulder strap anywhere else could damage your unit or cause your unit to fall.

To install the shoulder strap:

Attach each of the snap hooks to a D-shaped metal ring of the carry handle (one hook per ring), as shown below.



Getting Started with Your Unit

Installing or Removing FTB Module Adapters

Installing or Removing FTB Module Adapters

You can insert FTBx modules, FTB modules, or a combination of both in your unit. If you intend to work with FTB modules and your unit is not already equipped with module adapters, you must first install such adapters. These adapters must be removed before inserting FTBx modules.

To install the FTB modules adapters:

1. Position the adapter so that you can see the retaining screw as shown below.

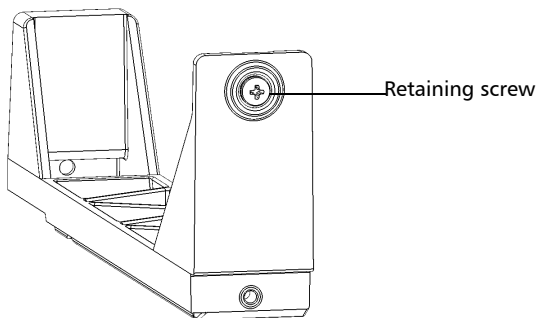

Getting Started with Your Unit

Installing or Removing FTB Module Adapters

2. Slide the adapter into the unit until it stops, making sure that the retaining screw is well aligned with the corresponding screw hole on the unit.

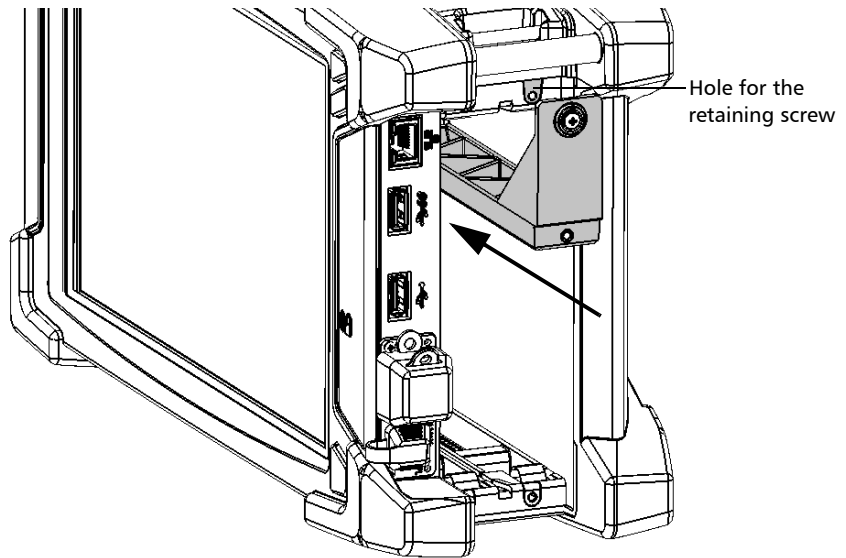

Getting Started with Your Unit

Installing or Removing FTB Module Adapters

3. Using a screwdriver, turn the retaining screw clockwise to secure the adapter in place.

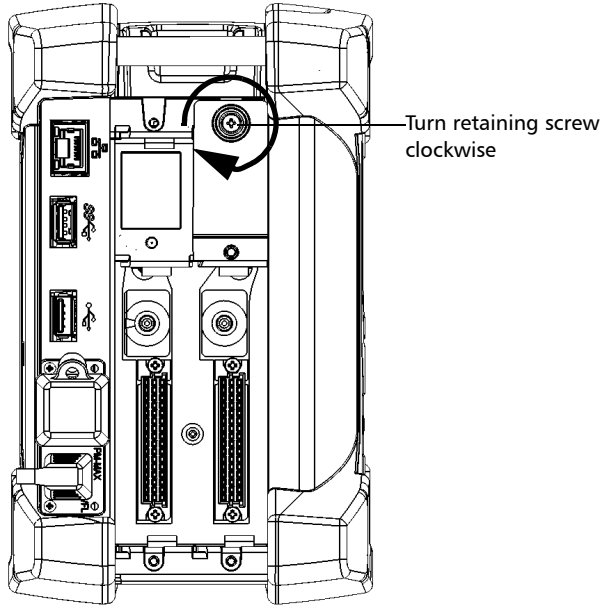

4. If necessary, repeat the steps above with a second adapter.
You are now ready to work with FTB modules.

To remove the FTB modules adapters:

1. Using a screwdriver, turn the retaining screw counterclockwise until it is loose. Since it is a captive screw, you cannot remove it completely.

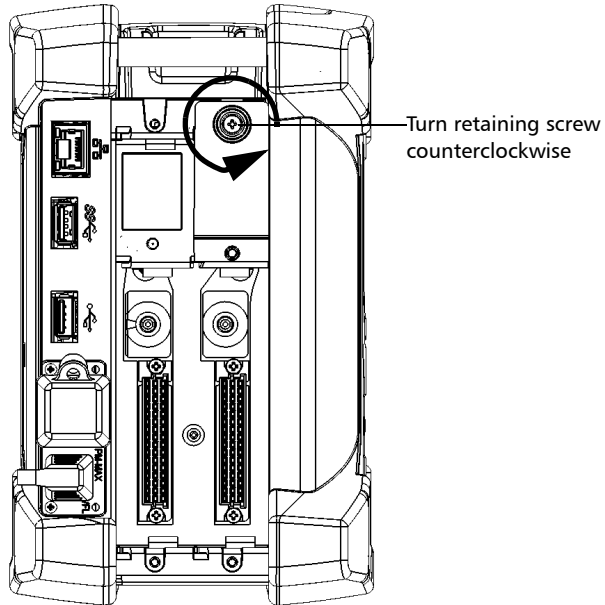

Getting Started with Your Unit

Installing or Removing FTB Module Adapters

2. Place your fingers just under the protruding edge on the faceplate of the adapter, and then slide the adapter out of the unit.

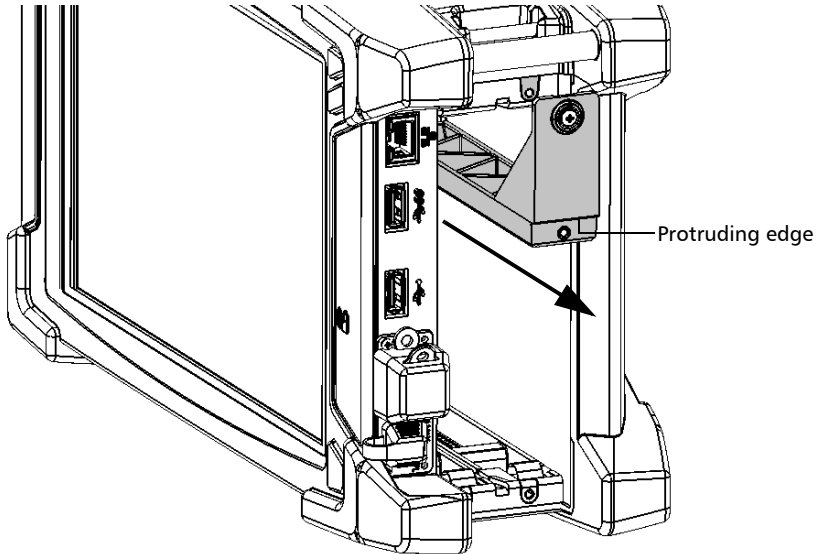

3. If necessary, repeat the steps above with the second adapter.
You are now ready to work with FTBx modules.

Inserting and Removing Test Modules



CAUTION

Never insert or remove a module while the FTB-2 or FTB-2 Pro unit is turned on. This will result in immediate and irreparable damage to both the module and unit.



CAUTION

Your unit is compatible with some of the FTBx modules and some of the FTB modules. For a list of supported modules, refer to your unit's technical specifications. To avoid damaging your unit, use it only with modules approved by EXFO.



IMPORTANT

You can insert FTBx modules, FTB modules, or a combination of both in your unit. However, to be able to work with the FTB modules, you need to first install module adapters. These adapters must be removed before inserting FTBx modules. For more information on how to install or remove the module adapters, see the corresponding section in this documentation.

To insert a module into the FTB-2 or FTB-2 Pro:

1. Turn off your unit (shut down, not hibernate or sleep).
2. Position the unit so that its right panel is facing you.

Getting Started with Your Unit

Inserting and Removing Test Modules

3. Take the module and place it so that the connector pins are at the back, as explained and shown below.

The identification sticker must be on the right side and the protruding edges on the left side. In the case of the FTB modules, ensure that the retaining screw hole is *over* the connector pins.

Right panel

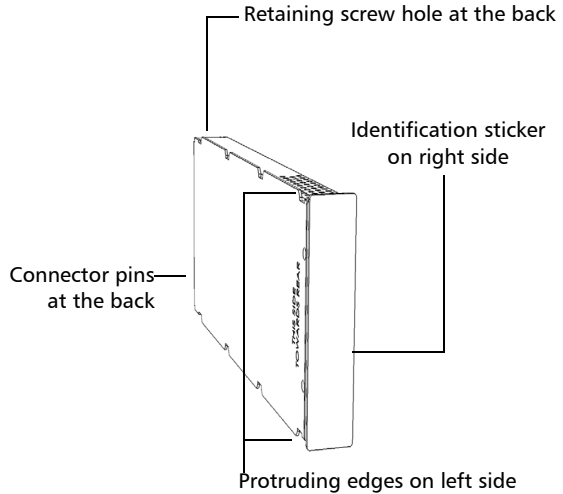
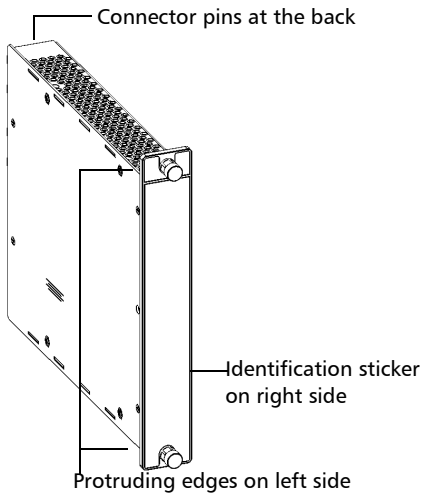
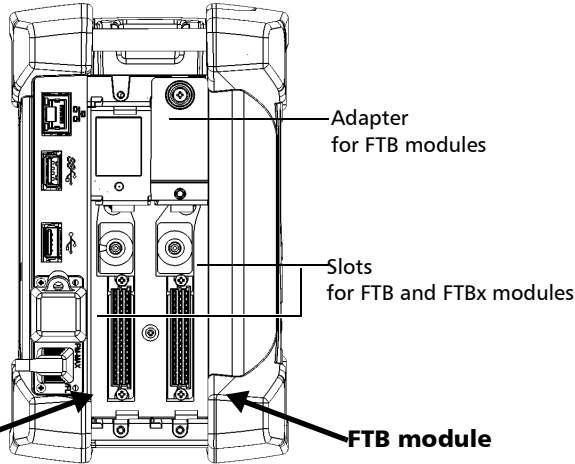

Getting Started with Your Unit

Inserting and Removing Test Modules

- 4. Insert the protruding edges of the module into the grooves of the receptacle's module slot.
- 5. Push the module all the way to the back of the slot, until it stops.
- 6. If you are working with an FTBx module, turn the two retaining screws clockwise until they are tightened.

This will secure the module into its "seated" position.

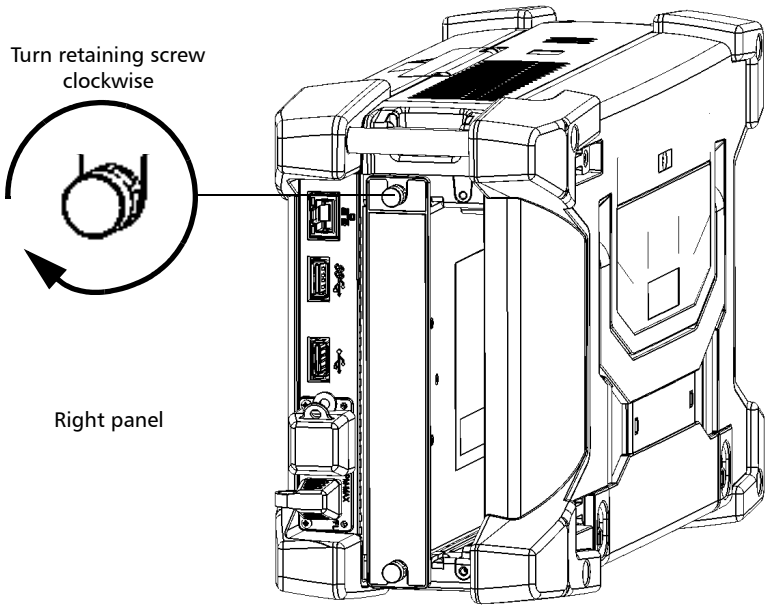

Getting Started with Your Unit

Inserting and Removing Test Modules

7. If you are working with an FTB module, secure it as follows:
 - 7a. Place the unit so that its left panel is facing you.
 - 7b. While applying slight pressure to the module, lift the mobile part of the retaining screw and use it to turn the retaining screw clockwise until it is tightened.

This will secure the module into its “seated” position.

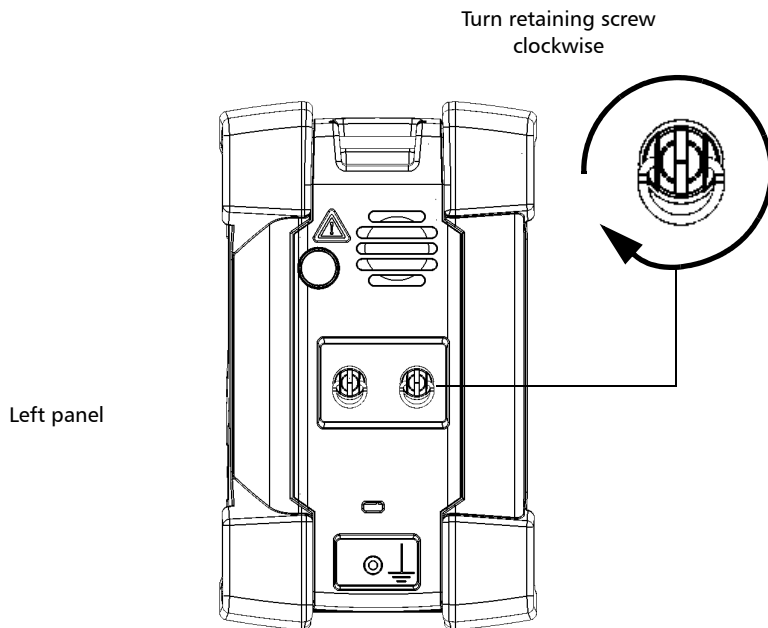



IMPORTANT

For FTB modules: EXFO recommends that you use the front locking screws to secure the modules in your unit, especially when you work with heavier modules such as the OSA, or the FTB-88100NGE PowerBlazer.

- 8.** If you are working with a larger or heavier FTB module, secure it with locking screws as follows:
 - 8a.** Position the unit so that its right panel is facing you.
 - 8b.** Insert a locking screw in one of the screw holes on the front of the unit.

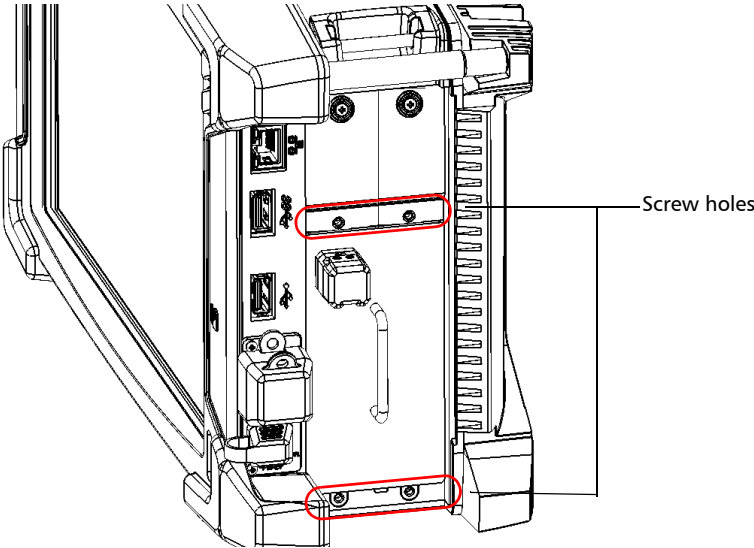

Getting Started with Your Unit

Inserting and Removing Test Modules

- 8c.** Turn the screw clockwise until it makes contact with the faceplate of the module.

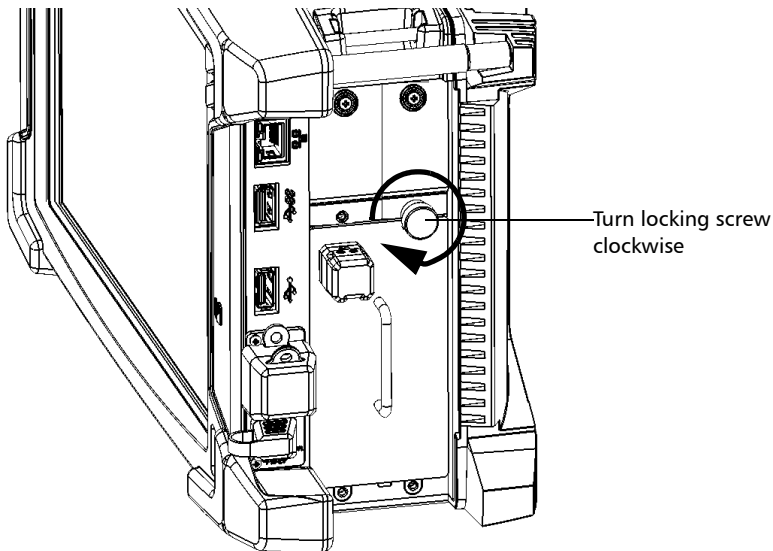

- 8d.** Repeat steps 8b and 8c with the three remaining screws.

When you turn on the unit, the startup sequence will automatically detect the module.

To remove a module from the FTB-2 or FTB-2 Pro:

1. Turn off your unit (shut down, not hibernate or sleep).
2. Position the unit so that its right panel is facing you.
3. If you are working with an FTBx module, turn the two retaining screws counterclockwise until they are loose. Since they are captive screws, you cannot remove them completely.

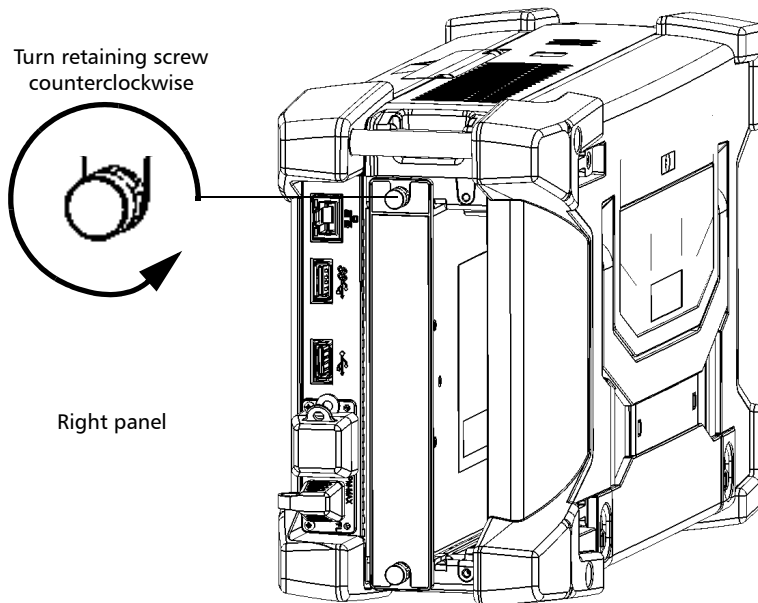

Getting Started with Your Unit

Inserting and Removing Test Modules

4. If you are working with an FTB module, proceed as follows:
 - 4a. Turn one locking screw counterclockwise until you can remove it completely.

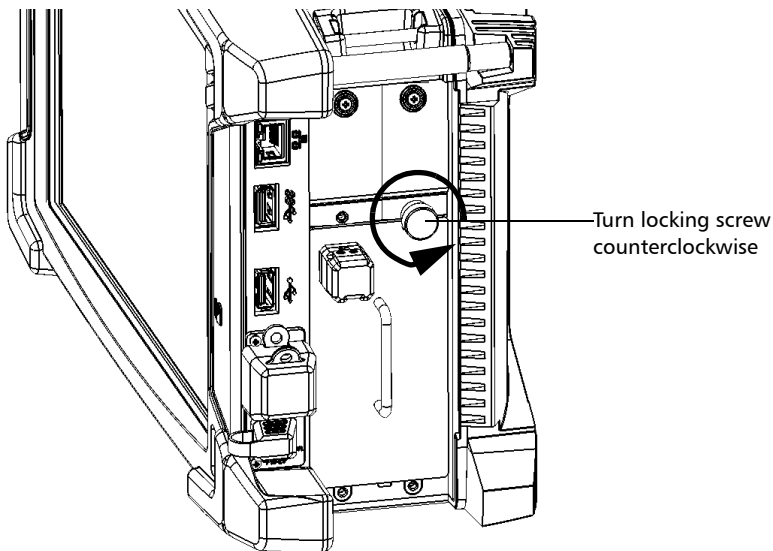

- 4b. Remove the three remaining screws in the same way.
 - 4c. Position the unit so that the left panel is facing you.

Getting Started with Your Unit

Inserting and Removing Test Modules

- 4d.** Lift the mobile part of the retaining screw and use it to turn the retaining screw counterclockwise until it stops.

The module will be slowly released from the slot.

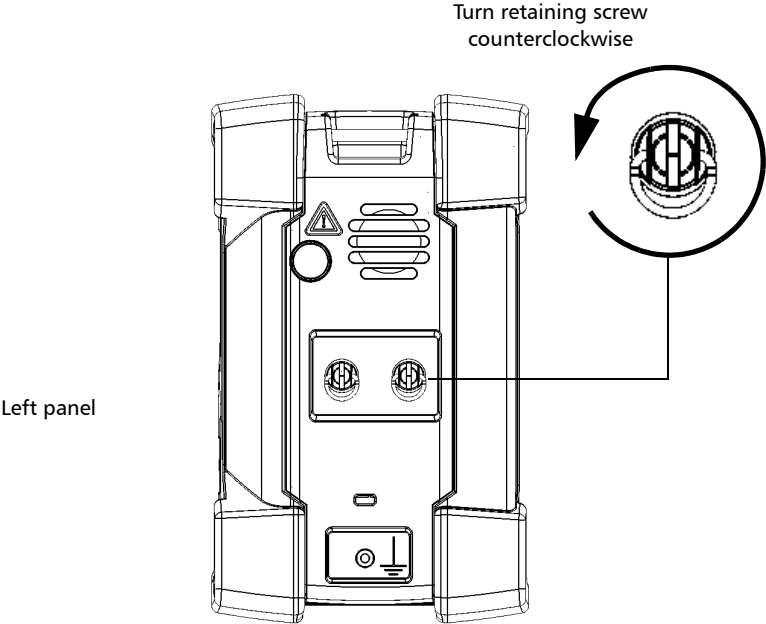

- 4e.** Place the unit so that the right panel is facing you.

Getting Started with Your Unit

Inserting and Removing Test Modules

5. Hold the module by its sides or by the handles (*NOT by the connectors*) and pull it out.

Note: *On the FTBx modules, the retaining screws can be used as handles to pull out the module safely.*

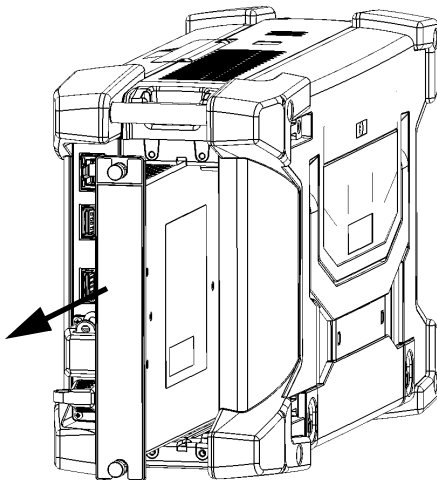

CAUTION

Pulling out a module by its connectors could seriously damage both the module and connectors. Always pull out a module by its casing or the handles.

6. Cover empty slots with the supplied protective covers.



CAUTION

Failure to reinstall protective covers over empty slots will result in ventilation problems.

Turning On Your Unit

When you turn on the unit for the very first time, a wizard for license agreements and safety instructions is displayed (see the corresponding section for more information).

Once you have accepted all the license agreements and confirmed the reading of safety instructions, the main window is displayed.

To turn on the unit:

Press the On/Off button.

Turning Off Your Unit

There are several ways to turn off the unit, including the following:

- *Sleep*: keeps the unit's status information in memory (RAM). The next time you turn your unit on, you will quickly return to your work environment (running applications will still be running). This mode will take more battery power while the unit is off.
- *Hibernation*: saves the unit's status information that was in memory (RAM) to a special file on the disk. The next time you turn your unit on, this file will be used to ensure that you return to your work environment (running applications will still be running). The unit will take longer to start up than in *Sleep* mode, but it requires less battery power when the unit is off.
- *Shutdown*: the unit will perform a complete restart routine the next time you use it. You should perform a shutdown if you do not intend to use your unit for a week or more.

After a shutdown, the unit will start in Toolbox X or in the application you defined as the startup application.

Note: *Should the unit ever stop responding, you can force a hardware reset by pressing and holding down the power button for more than 15 seconds.*

Getting Started with Your Unit

Turning Off Your Unit

By default, your unit will shut down when you press the power button. However, you can configure your unit to perform a different action when the power button is pressed.

You can also configure your unit to automatically restart when AC power comes back after the unit has turned off (power outage, emergency shutdown, sleep, or hibernation modes) when battery level is too low.

To exit the sleep mode (or hibernation mode) and resume your work:

Press the On/Off button.

To turn off the unit completely from the unit itself:

Press the On/Off button.

To turn off the unit completely from Windows:

1. From the right side of the screen, swipe left to display the Charm bar. For more information, see the section about working with Windows 8.1 Pro or Windows Embedded 8 Standard.
2. Tap **Settings > Power > Shut down**.

To define the behavior of the power button:

- 1. From the main window, tap the **System Settings** button.
- 2. Tap **Control Panel**.



- 3. Tap **Hardware and Sound**.

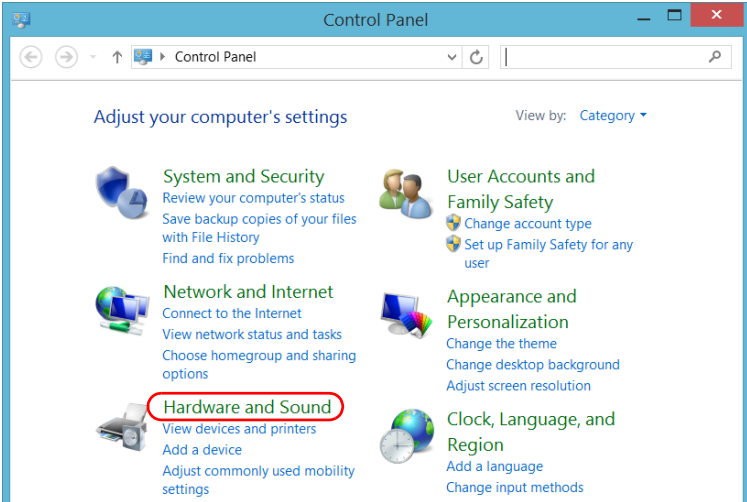

Getting Started with Your Unit

Turning Off Your Unit

4. Under **Power Options**, tap **Change what the power buttons do**.

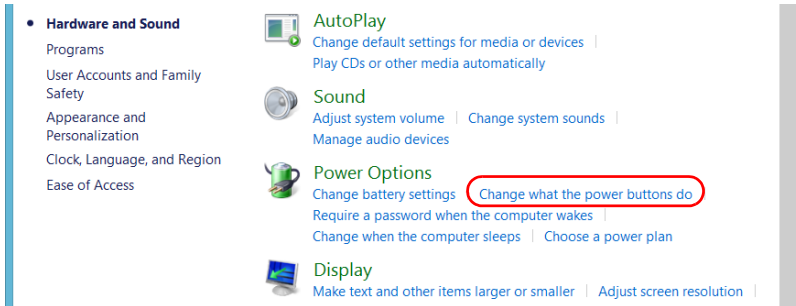

5. Tap **Changes settings that are currently unavailable**.

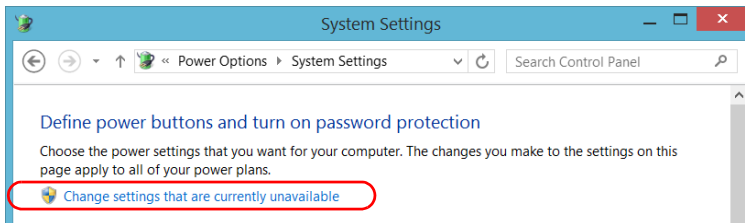

- From the **When I press the power button** lists, select the desired behavior when the unit is powered by batteries, or by AC current (**Shut down** option is selected by default in both cases).



- Tap **Save changes** to confirm the changes and return to the **Power Options** window.

Getting Started with Your Unit

Turning Off Your Unit

To configure your unit to automatically restart after AC power comes back:

1. From the main window, tap the **System Settings** button.
2. Tap **ToolBox X Setup**.



3. Select the **Power on the unit when AC outlet is connected or after power outage** box to enable the corresponding option.

OR

Clear the box if you prefer that your unit does not restart automatically after AC power comes back.

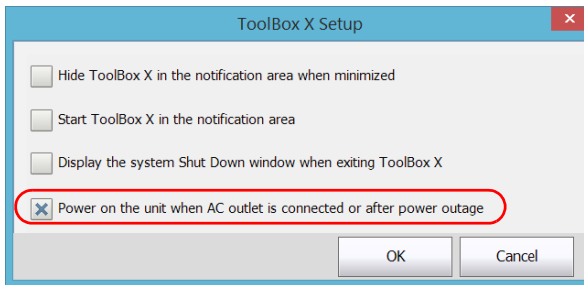

4. Tap **OK** to confirm the changes and return to the **System Settings** window.

Configuring Your Unit At First Startup

The first time you turn on the unit, a Windows configuration wizard is displayed, enabling you to set all the regional and language settings such as the country and operation language.



IMPORTANT

The operation language that you select at the first startup (labelled "App language") becomes the default system language, that is the language that will be available at logon.

During the configuration process, you will also be asked to read and accept the Microsoft end-user license agreement (EULA).

Once the configuration is complete in Windows, an EXFO wizard will be displayed, allowing you to read the user documentation for important safety information, and to read and accept the EULA related to your unit and instruments.

Note: *To be able to work with the unit, you must accept all the EULA (from Microsoft and EXFO), and confirm that you have read the security information.*

To configure your unit at first startup:

1. If it is not already done, turn on the unit (see *Turning Off Your Unit* on page 49).
2. When the Windows wizard is displayed, set the parameters according to your needs.
3. Read and accept the Microsoft EULA.
The configuration of Windows parameters may take several minutes.

Getting Started with Your Unit

Configuring Your Unit At First Startup

4. When the EXFO wizard is displayed, follow the on-screen instructions.

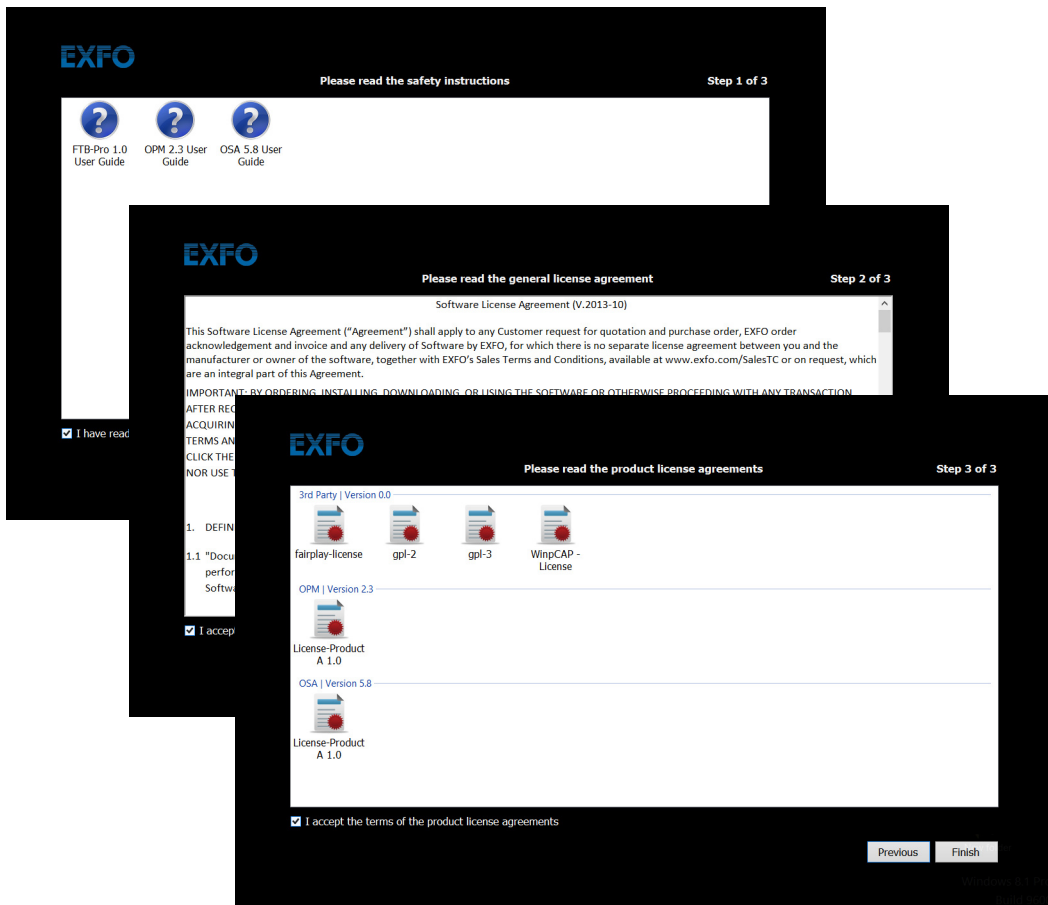

5. Tap **Finish** to close the wizard and start working.

Accessing and Exiting ToolBox X

By default, ToolBox X is displayed automatically when you turn on the unit.

However, you can configure your unit to send ToolBox X to the notification area (see *Setting ToolBox X Behavior* on page 122). This could be useful, for example, if you prefer to start working in Windows. You can also configure your unit to start any of the available applications as soon as ToolBox X is started (see *Selecting the Startup Applications* on page 94).

To access ToolBox X from the Windows environment:

Double-tap the  icon on your desktop.

Note: *If ToolBox X has been sent to the notification area, from this location, right-click the  icon, and then select **Restore ToolBox X**.*

To exit ToolBox X:

Tap .

Getting Started with Your Unit

Starting Module Applications

Starting Module Applications

Your modules can be configured and controlled from their dedicated applications in Toolbox X.

To start a module application:

1. If necessary, tap the **Modules** button to display the modules window.

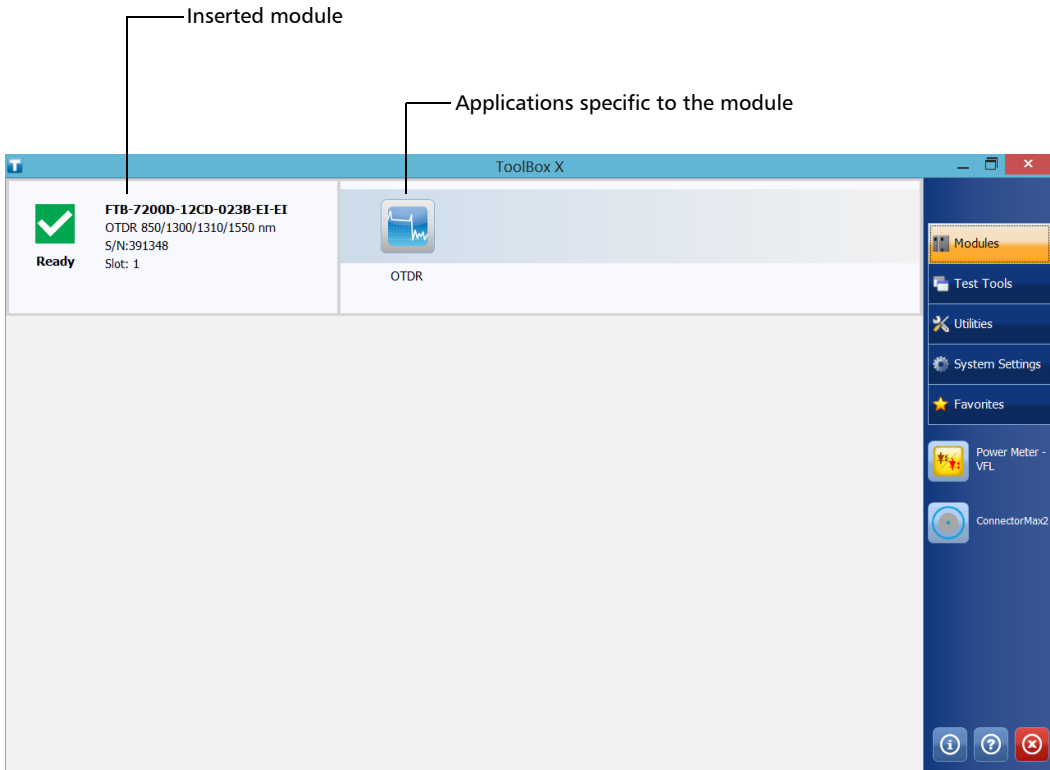

Note: The slots are identified by 1 and 2 both on the unit and in Toolbox X.

2. On the row corresponding to the desired module, tap the icon of the application with which you want to work.

Using the On-Screen (Virtual) Keyboard

Whenever you need to enter alphanumeric data, you can use the on-screen keyboard. This keyboard supports multilingual features, and functions according to the keyboard settings set in Windows.

To use the on-screen keyboard:

1. Select the location where you want to enter text.
2. From the unit's front panel, press the  button.
OR
3. From the taskbar, tap the on-screen keyboard icon (located to the left of the clock).



4. Enter the data as required.
5. Close the keyboard when you are done entering data.

Working with Windows 8.1 Pro or Windows Embedded 8 Standard

If you are not familiar with Windows 8.1 Pro (FTB-2 Pro) or Windows Embedded 8 Standard (FTB-2), you may want to visit Microsoft Web site for tutorials as well as detailed information on the features and concepts brought by this operating system.

One of the new features is the use of touchscreen gestures to perform certain tasks. In this documentation, all the necessary gestures are explained throughout the procedures.

Note: *For an optimal accuracy with the touchscreen, use the stylus provided with your unit.*

Here is an overview of the gestures that you may use the most with your unit.

- Tap and double-tap: Equivalent of a click and double-click with a mouse.
- Swipe right: To return to the last used application.
From the left edge of the screen, swipe towards the right.

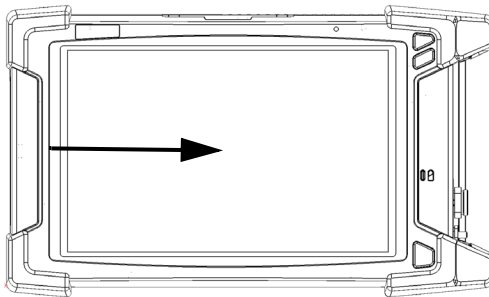

Getting Started with Your Unit

Working with Windows 8.1 Pro or Windows Embedded 8 Standard

- **Swipe down:** To close windows that do not have a close button. From the top edge of the screen, swipe towards the bottom.

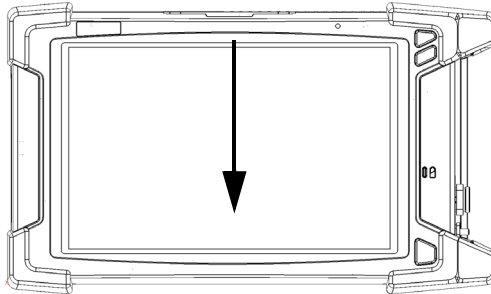

- **Swipe left:** To display the Charm bar, which is a special toolbar that gives you access to many tools and settings. From the right edge of the screen, swipe towards the left.

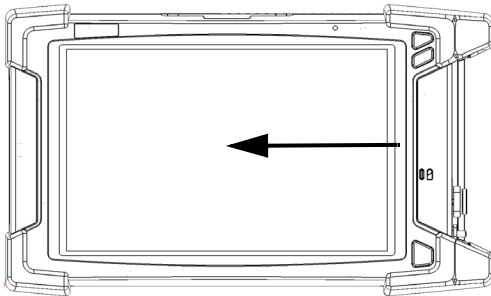

Right-Clicking with the Touchscreen

If you are used to work with a mouse, you may find it useful to be able to perform a right-click on your touchscreen.

This feature is enabled by default, but you can disable it if you prefer. You can also modify the right-click behavior. For more information, see *Customizing the Right-Click Feature* on page 86.

To right-click with the touchscreen:

From the location where you want to right-click, using the stylus or any blunt pointing device, press the screen for a few seconds until the shortcut menu appears.

If you want to hide the shortcut menu without performing any action, simply tap anywhere outside the menu.

Installing or Upgrading the Applications

All the necessary applications have been preinstalled and configured at the factory. However, you may have to upgrade some applications when new versions become available or to reinstall them.

Note: *Only administrator-level users can install software under Windows.*

Each time you purchase a new module, it could be a good idea to verify that the most recent Update Manager application is installed on your unit.

When updates are available for an application, you will need to download them from Internet, either directly on your unit or on a computer. The update files must be copied to the location that has been specified for the deployment packages in Update Manager.

For the installation or upgrade, you will need:

- your unit
- a computer equipped with a USB port; Windows must be installed on the computer
- a USB memory key

Note: *The computer and USB key are only necessary if you do not wish to download the files directly on your unit.*

Note: *For more information on the installation, refer to the Update Manager online help.*

Getting Started with Your Unit

Installing or Upgrading the Applications

To update or reinstall Update Manager:

- 1.** If necessary, retrieve the desired installation files from the Internet.
If you do not intend to download files directly on your unit, connect a USB memory key to one of the USB ports of the computer and copy the installation files to this USB key.
- 2.** If it is not already done, turn on your unit.
- 3.** Exit Toolbox X and the modules' applications.
- 4.** If you want to install Update Manager using the USB key, disconnect it from the computer and connect it to one of the USB ports of your unit.
- 5.** On your unit, create a folder on the Windows desktop.
- 6.** Copy the installation files (from the USB key) to the newly created folder.
- 7.** From the newly created folder, double-tap the Update Manager setup file to start the installation.
- 8.** Follow the on-screen instructions.
- 9.** When the installation is complete, simply disconnect the USB memory key.

To install or upgrade the applications:

- 1.** If necessary, retrieve the desired installation files from the Internet.

If you do not intend to download files directly on your unit, connect a USB memory key to one of the USB ports of the computer and copy the installation files to this USB key.
- 2.** If it is not already done, turn on your unit.
- 3.** Exit Toolbox X and the modules' applications.
- 4.** If you want to install or update applications using the USB key, disconnect it from the computer and connect it to one of the USB ports of your unit.
- 5.** Copy the installation files (from the USB key) to the folder containing the update and installation packages on your unit. By default, Update Manager will search for files at the root of the USB key. For more information, refer to the Update Manager online help.
- 6.** On your unit, from Windows desktop, double-tap the **Update Manager** icon to start the corresponding application. For more information on how to install or upgrade applications, refer to the Update Manager online help.
- 7.** When the installation is complete, simply disconnect the USB memory key.

Activating Software Options

The software options purchased at the same time as your unit have been activated for you already. However, if you purchase options afterwards, you will have to activate them yourself.

Before being able to activate options, you need to contact EXFO with the following information:

- Purchase order number of the newly purchased options
- Module or platform serial number (depending on whether the software options were purchased for a module or the platform)
- Customer's name
- Customer's company name
- Customer's phone number
- Customer's e-mail address
- Module or platform on which the option will be installed

You will receive a single key (.key) file with which you will be able to unlock all the new options that you have purchased.

To activate the options for your unit:

- 1.** Connect a USB memory key to one of the USB ports of your computer.
- 2.** Copy the key file to the USB memory key.
- 3.** Disconnect the USB key from the computer and connect it to your unit.
- 4.** From the main window, tap the **System Settings** button, and then tap **Options Activation**.

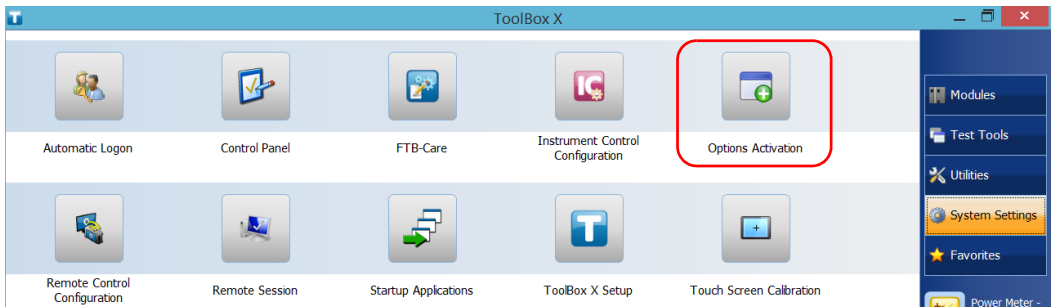

Getting Started with Your Unit

Activating Software Options

5. In the **Platform Options** tab, use the **Browse** button to locate the key file that you want to use.

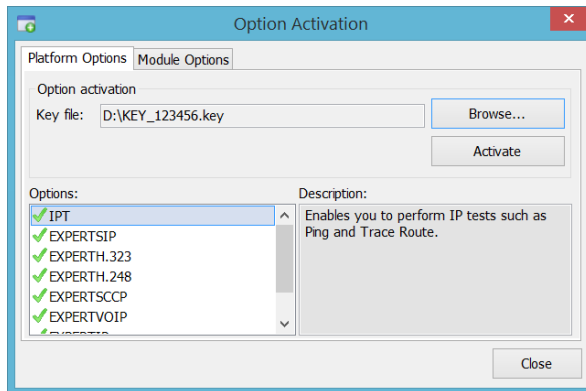

6. Tap **Activate**.

The option indicator will turn into a green check mark to confirm that the option is now active.

7. Tap **OK** to close the confirmation message, and then **Close** to exit.

Note: *At this point, if you have used a USB key to copy your key file, you can remove it as it is not required to use your new options.*

To activate software options for your module:

- 1.** Connect a USB memory key to one of the USB ports of your computer.
- 2.** Copy the key file to the USB memory key.
- 3.** Disconnect the USB key from the computer and connect it to your unit.
- 4.** From the main window, tap the **System Settings** button, and then tap **Options Activation**.



Getting Started with Your Unit

Activating Software Options

5. In the **Module Options** tab, use the **Browse** button to locate the key file that you want to use.

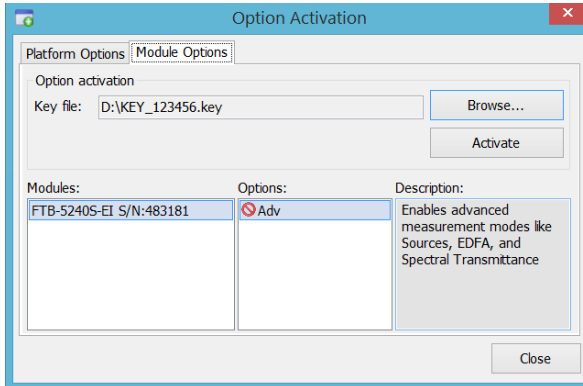

6. Tap **Activate**.

The option indicator will turn into a green check mark to confirm that the option is now active.

Note: You can see the supported options for the module in the **Options** list.

7. Tap **OK** to close the confirmation message, and then **Close** to exit.

Note: At this point, if you have used a USB key to copy your key file, you can remove it as it is not required to use your new options.

Installing Third-Party Software on Your Unit

The applications that can be installed on your unit depend on your specific model (FTB-2 units do not have the same type of license as FTB-2 Pro units).



IMPORTANT

- On the FTB-2, to comply with the terms of the Microsoft license, you should only install antivirus software and the applications provided by EXFO.
- On the FTB-2 Pro, you can install any third-party software, as long as it is compatible with Microsoft Windows 8.1 Pro.

In all cases, EXFO does not provide any support for the installation, use or troubleshooting of third-party software. Should you need help, refer to the corresponding third-party software documentation or technical support.

Protecting your Unit with an Antivirus Software

By default, your unit is protected with the Windows Defender antivirus software. However, you can apply your own security standards and antivirus strategy.

Getting Started with Your Unit

Securing your Unit Using the Kensington Lock

Securing your Unit Using the Kensington Lock

Your unit is equipped with a security slot to which you can connect an optional Kensington lock (security cable) to help prevent theft.

To secure your unit:

Connect your lock to the security slot located on the left panel of your unit.

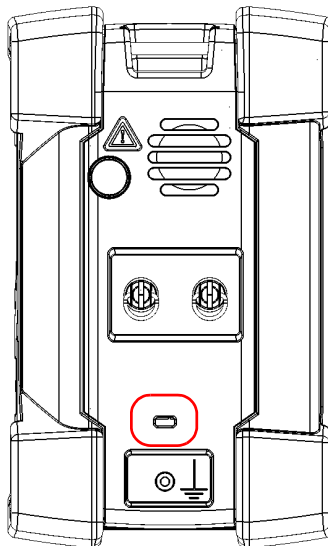

Using a Keyboard, Mouse or Other USB Devices

Your unit supports many USB devices. The table below gives an overview of the supported USB devices.

Device	Details
Memory key	For data transfer between your unit and a computer when you do not have access to a network. If you need information on how to transfer data using a memory key, see <i>Managing Data</i> on page 149.
Keyboard	When you are required to enter alphanumeric data, an on-screen (virtual) keyboard is displayed. However, if you prefer, you can use a hardware keyboard. Note: <i>Even if a keyboard is connected, the on-screen keyboard will still be displayed when you work in Toolbox X.</i>
Mouse	If you prefer to use a mouse instead of the touchscreen, you can connect one.
Composite device	You can use composite devices, that is devices that input information to your unit using more than one mean (for example, combinations of keyboard and mouse).
Hub	This device will be particularly useful to you if you need extra USB ports.
Printer	To print documents such as reports directly from you unit. If you prefer to use a network printer, you can also configure one. For more information, see <i>Configuring Network Printers</i> on page 96.

Getting Started with Your Unit

Using a Keyboard, Mouse or Other USB Devices

Device	Details
3G USB modem key	To access the Internet without having to connect to a Wi-Fi or an Ethernet network. For more information, see <i>Accessing the Internet with a 3G USB Modem Key</i> on page 133.
USB to RS-232 adapter (purchased from EXFO)	To be able to transfer data between your unit and a device only equipped with RS-232 (serial) ports. For more information, see <i>Using the USB to RS-232 Adapter</i> on page 162.

You can connect several devices at the same time.

To use a USB device with your unit:

Connect the USB device to any of the USB ports located on the right panel or on the top of the unit (see *Main Features* on page 1).

Note: *It is not necessary to turn off the unit before connecting the USB device. The software will automatically detect its presence.*

Your device is automatically recognized and immediately usable (provided that it uses the drivers already available on your unit).

Working with Bluetooth Devices

If you have purchased the Wi-Fi and Bluetooth option, you can use many Bluetooth devices with your unit.

With the supported Bluetooth profiles, you can do the following:

- Use a wireless mouse and keyboard.
- Use a wireless headset.
- Print from your unit to a Bluetooth-enabled printer.
- Transfer files between your unit and a cell phone (see *Transferring Data via Bluetooth* on page 151).
- Share files between your unit and Bluetooth-enabled computers (see *Transferring Data via Bluetooth* on page 151).

4 **Setting Up Your FTB-2 and FTB-2 Pro**

Adjusting Brightness

You may want to adjust the screen brightness yourself to better fit your work environment or preferences. Values are kept in memory even when you turn the unit off.

If you want to set the delay after which the display is dimmed to save power, see *Configuring the Power Management Options* on page 112.

To adjust the display brightness:

1. From the right side of the screen, swipe left to display the Charm bar.
2. Tap **Settings**, and then the  icon.
3. Move the slider until the screen appearance is to your liking.

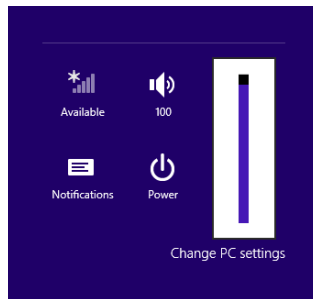

The new brightness value is taken into account immediately.

Setting Up Your FTB-2 and FTB-2 Pro

Adjusting Microphone and Speaker Volume

Adjusting Microphone and Speaker Volume

To fit your work environment, you may adjust the microphone and speaker (or headphones) volume. Values are kept in memory even when you turn the unit off.

To adjust microphone volume:

1. Ensure that your headset is connected to the audio port located on the top panel of the unit.

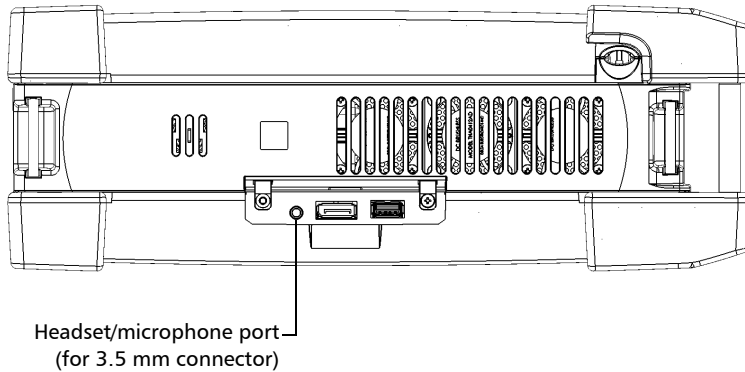

2. From the main window, tap the **System Settings** button.
3. Tap **Control Panel**.



4. Tap **Hardware and Sound**.

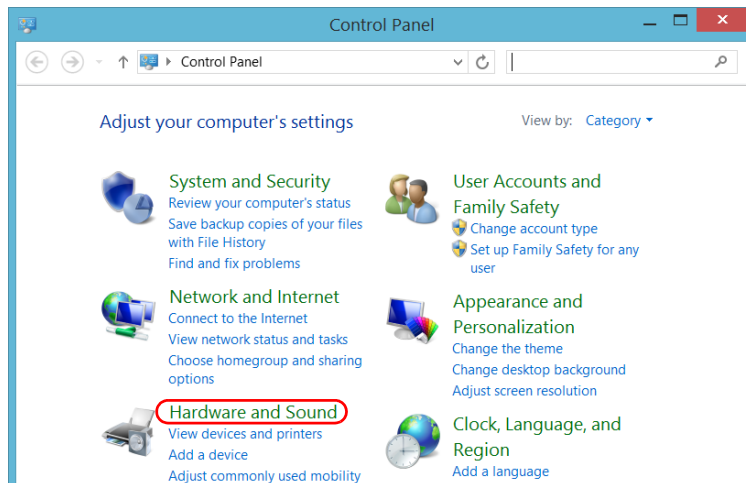

5. Under **Sound**, tap **Manage audio devices**.

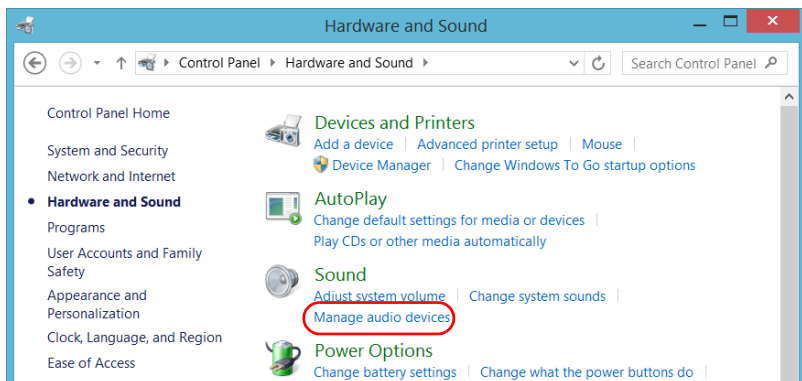

Setting Up Your FTB-2 and FTB-2 Pro

Adjusting Microphone and Speaker Volume

6. Select the **Recording** tab.
7. Ensure that your microphone is selected, and then tap **Properties**.

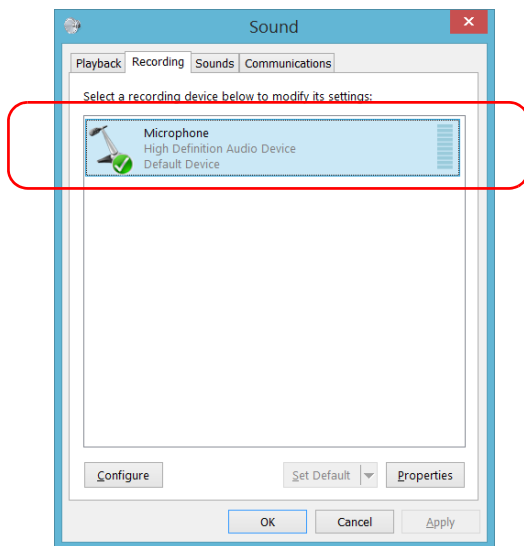

Setting Up Your FTB-2 and FTB-2 Pro

Adjusting Microphone and Speaker Volume

- From the **Levels** tab, move the sliders until the settings are to your liking. If the sound coming from your microphone is too low, you may want to adjust the boost level as well.

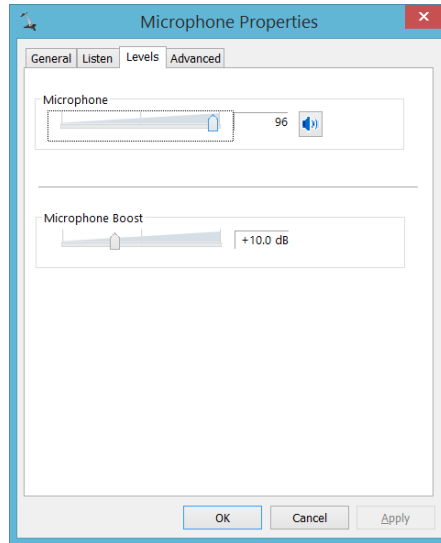

- Tap **OK** to confirm your new settings and close the window.
- Tap **OK** to close the window and return to Control Panel.

Setting Up Your FTB-2 and FTB-2 Pro

Adjusting Microphone and Speaker Volume

To adjust speaker (or headphones) volume:

1. From the right side of the screen, swipe left to display the Charm bar.
2. Tap **Settings**, and then the  icon.
3. Move the slider until the sound level is to your liking.

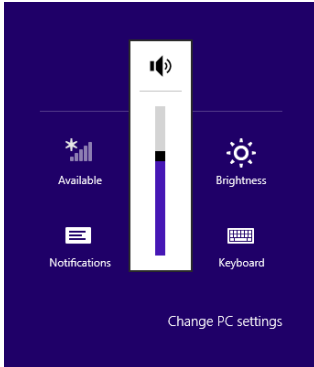

Note: You can also access the sound level slider by tapping the  icon from the taskbar.

The new value is taken into account immediately.

Recalibrating the Touchscreen

If you notice the touchscreen does not behave in the way it used to (for example, it is now difficult to select items) it probably needs a recalibration. You can perform a 4-point, 9-point (linearization), or even a 25-point (linearization) calibration. You can perform a 25-point linearization when you need more accuracy on screen edges and corners.

You can stop the calibration process at any time, but the touchscreen will still need calibration. The parameters are taken into account only when the process is complete.

Note: *If you have trouble accessing the touchscreen calibration feature because the touchscreen is not behaving as expected, you can connect a USB mouse.*



IMPORTANT

To get the optimum performance out of your touchscreen:

- Always use the calibration tool provided with ToolBox X (not the tool provided with Windows).
- Be as accurate as possible when you press the center of the targets that appear during touchscreen calibration. This will ensure a greater accuracy of the touchscreen, especially along the edges and in corners.

Setting Up Your FTB-2 and FTB-2 Pro

Recalibrating the Touchscreen

To recalibrate the touchscreen:

1. From the main window, tap the **System Settings** button.
2. Tap **Touch Screen Calibration**.

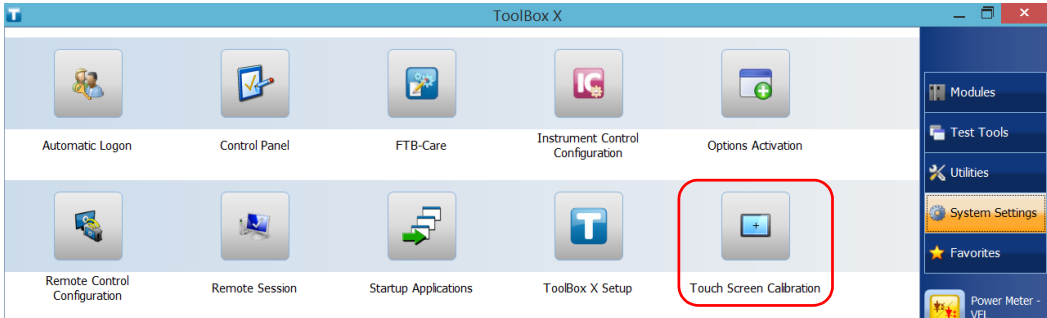

3. Tap the button corresponding to the type of calibration (or linearization) that you want to perform.

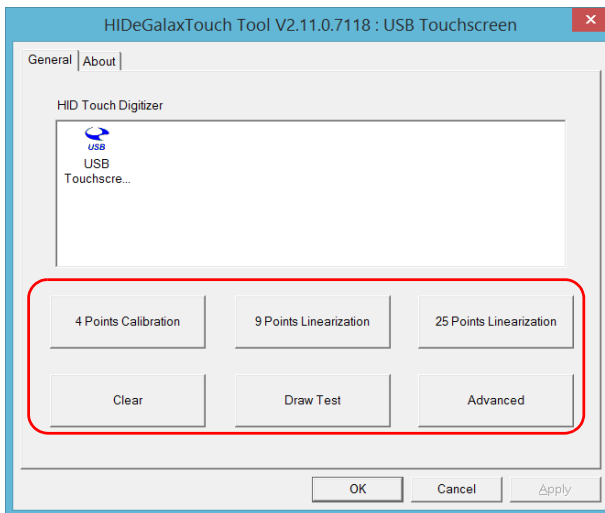

- Using the stylus (or any blunt pointing device), simply press the center of the different targets that appear on the screen. Keep pressing until the application displays **OK** to indicate that the new parameters have been taken into account.

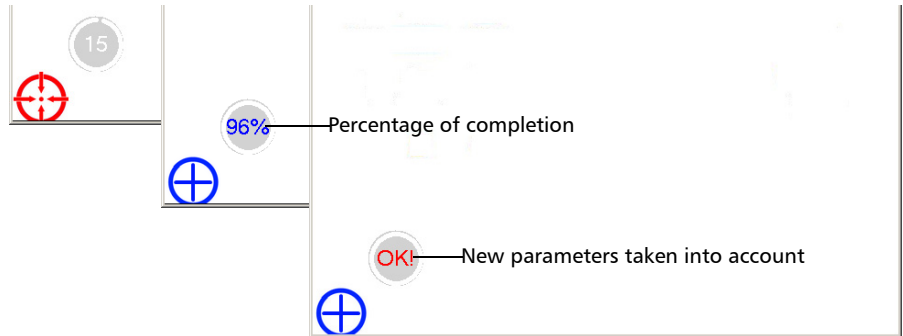

Note: *If you want to stop the calibration process, stop pressing the screen. The application will close automatically after a few seconds and you will return to the **System Settings** window.*

- When you see the message indicating that the calibration is complete, tap **OK** to return to the **System Settings** window.

Customizing the Right-Click Feature

By default, you can perform a “press and hold” action which corresponds to right-clicking with your touchscreen (see *Right-Clicking with the Touchscreen* on page 62). However, you can disable this feature if you prefer.

You can also modify the delay before the unit considers that you are right-clicking, as well as the amount of time before displaying the shortcut menu once you have right-clicked.

To customize the right-click feature:

1. From the main window, tap the **System Settings** button.
2. Tap **Control Panel**.



3. Tap **Hardware and Sound**.

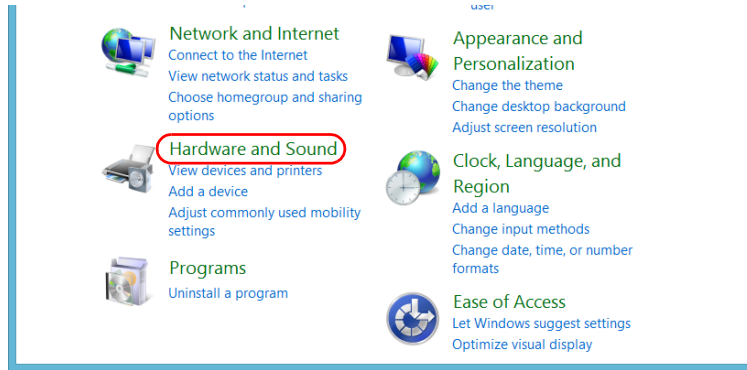

4. Tap **Pen and Touch**.

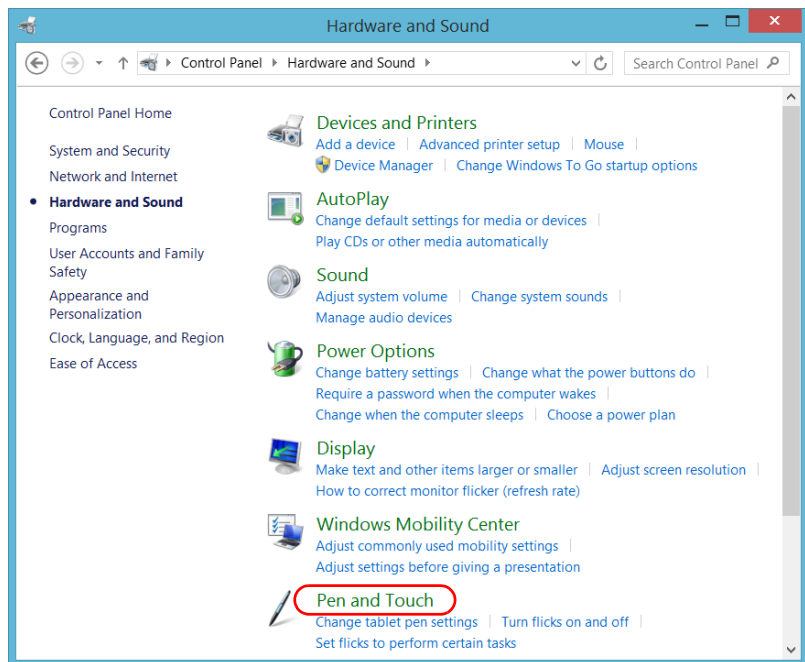

Setting Up Your FTB-2 and FTB-2 Pro

Customizing the Right-Click Feature

5. From the list, select **Press and hold**.

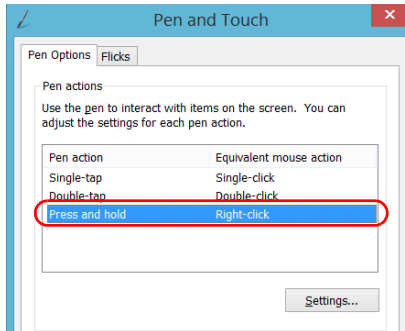

6. Tap **Settings**.
7. If you want to use the right-click feature with your unit, select the **Enable press and hold for right-clicking** check box. Clear the check box if you prefer not to use this feature.

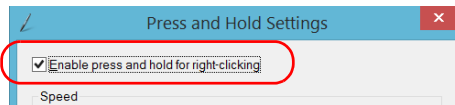

8. If you want to modify the response time of the right-click, move the **Speed** or **Duration** sliders to adjust the configuration to your needs.

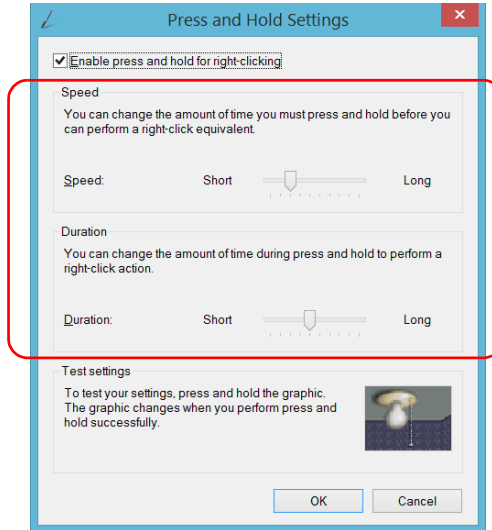

9. Tap **OK** to confirm your changes.

Enabling or Disabling the Automatic Logon

Note: *Only administrator-level users can enable or disable the automatic logon feature.*

You can configure your unit to automatically log on to Windows at startup (no need to select a user and enter a password). You can also disable this feature if you prefer to define separate user accounts with different user access rights and passwords.

Note: *For security reasons, when the unit comes back from sleep mode, the application will prompt you to select a user and enter a password, even if you have enabled the automatic logon feature.*

Also for security reasons, by default, the automatic logon is not enabled. Once it is enabled, if you want to modify the password of the user account for which the automatic logon is enabled, you will have to disable the feature first, and then enable it again once the new password is defined.

If you want to modify the account used for the automatic logon, you will also have to disable the feature first, and then enable it again for the new account.



IMPORTANT

The user name and password that you specify for the automatic logon must correspond to those of an existing user account.

You can create user accounts or modify passwords from the Accounts window (For FTB-2: Charm bar > Settings > Change PC settings > Users; for FTB-2 Pro: Charm bar > Settings > Change PC settings > Accounts).

To enable the automatic logon:

1. From the main window, tap the **System Settings** button.
2. Tap **Automatic Logon**.



3. From the User Accounts window, clear the **Users must enter a user name and password to use this computer** check box.

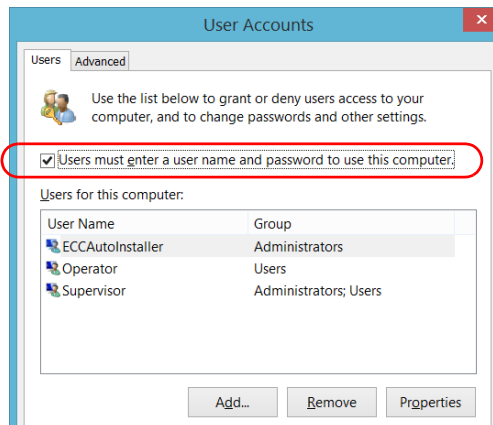

4. Tap **OK** to confirm.

Setting Up Your FTB-2 and FTB-2 Pro

Enabling or Disabling the Automatic Logon

5. Enter the desired user name (account) and the corresponding password.

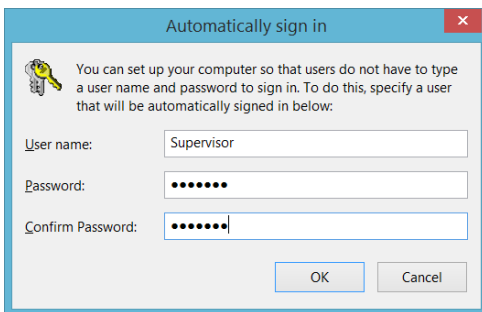

6. Tap **OK** to confirm and to return the **System Settings** window.

At next startup, you will no longer need to specify a user name and password (except if the unit comes back from sleep mode).

To disable the automatic logon:

1. From the main window, tap the **System Settings** button.
2. Tap **Automatic Logon**.



3. From the User Accounts window, select the **Users must enter a user name and password to use this computer** check box.

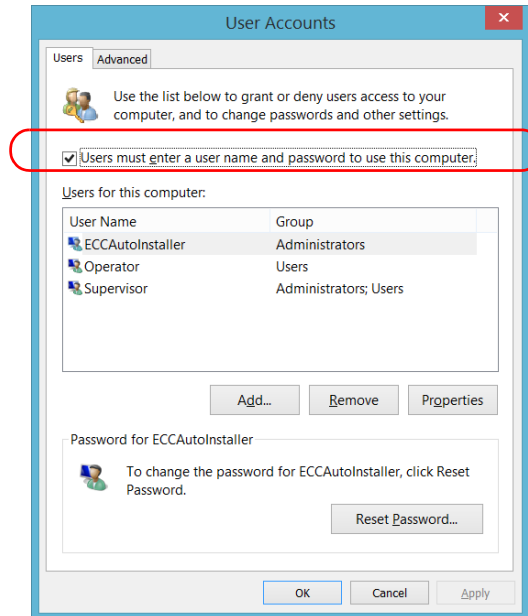

4. Tap **OK** to confirm and to return the **System Settings** window.
At next startup, you will have to specify the user name and password.

Selecting the Startup Applications

The first time you start your unit, Toolbox X is displayed. You can configure your unit to automatically start any of the available applications as soon as ToolBox X is started. This can save you time, as you do not need to ensure that they are already running before starting your tests.

If the required module is not present in the unit, the specified applications will simply not be started. In some cases, you may have to select the applications again the next time the module is inserted into the unit.

To set applications to start automatically at ToolBox X startup:

1. From the main window, tap the **System Settings** button.
2. Tap **Startup Applications**.

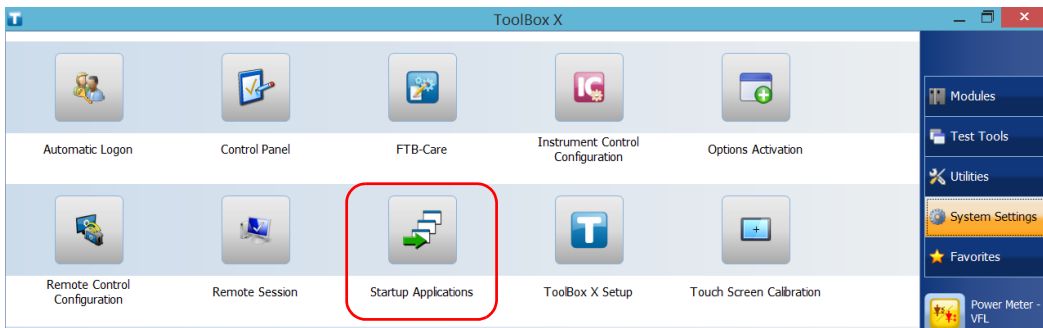

- Under **Module Applications** or **Other Applications**, select the applications you want to start automatically by selecting the corresponding check boxes.

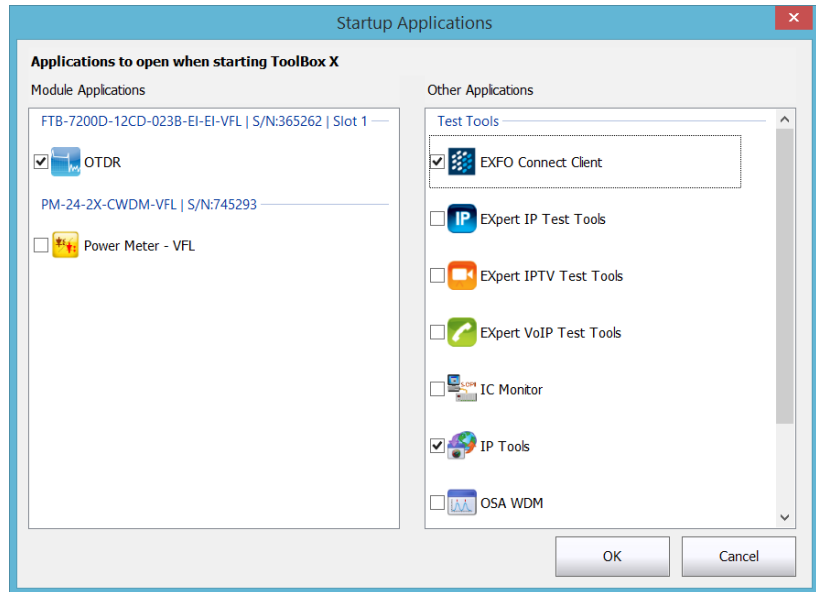

- Tap **OK** to use the new settings. Tap **Cancel** to exit without using the new settings.

Note: *The new settings will be taken into account the next time ToolBox X is started.*

Configuring Network Printers

Your unit supports both (local) USB and network printers (you may have to install specific drivers on your unit).

For more information on USB printers connection, see *Using a Keyboard, Mouse or Other USB Devices* on page 73.

To print documents and images on a network printer, you must configure the printer first. You must know the IP address of the network printer that you want to configure, and ensure that your unit is connected to the same network as the printer (either wireless or Ethernet connection). Contact your network administrator for more information on your specific network configuration.

For more information on printing, see *Printing Documents* on page 129.

To configure the printer:

1. From the main window, tap the **System Settings** button.
2. Tap **Control Panel**.



3. Under **Hardware and Sound**, tap **View devices and printers**.

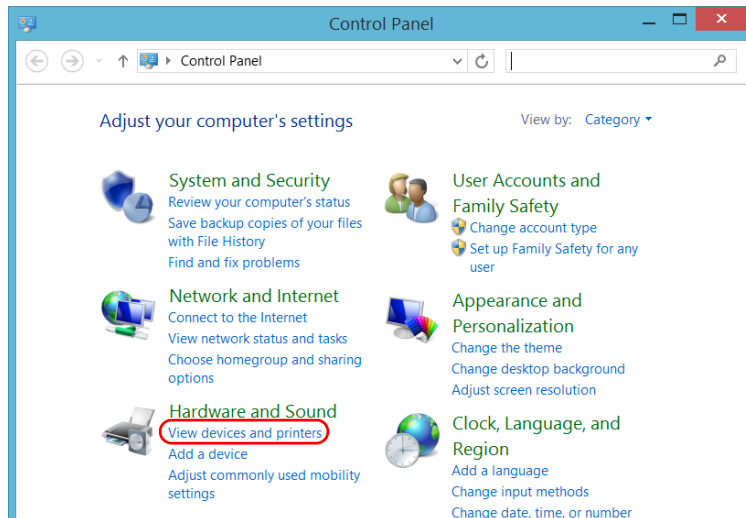

4. Tap **Add a printer**.

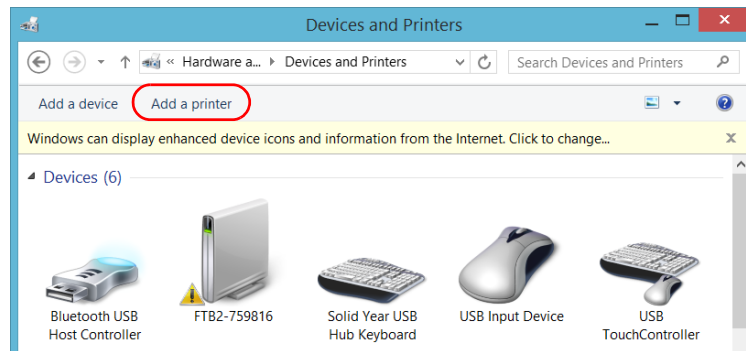

5. Follow the on-screen instructions.

Selecting the Language of Operation

You may display the user interface in one of the available languages.

The availability of the languages is function of the language group that was installed on your unit at time of purchase. It is possible to download language packs from the Microsoft Website to add extra languages if necessary.

The ToolBox X application is offered in several languages. This means that if ToolBox X supports the language currently selected in Windows, it will automatically be displayed in this language. If the selected language is not supported, the English version will be used.

When you change the interface language, the corresponding keyboard is automatically added to the list of available keyboards. You can then enter text in a specific language (both on-screen or “real” keyboards). Once the keyboards are added, you can switch easily from one input language to another.

Values are kept in memory even when you turn the unit off.

To select a new interface language:

- 1.** From the main window, tap the **System Settings** button.
- 2.** Tap **Control Panel**.

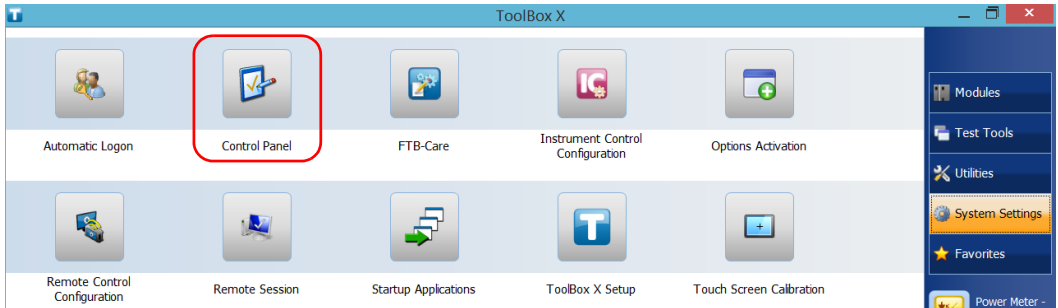

Setting Up Your FTB-2 and FTB-2 Pro

Selecting the Language of Operation

3. Under **Clock, Language, and Region**, tap **Add a language**.

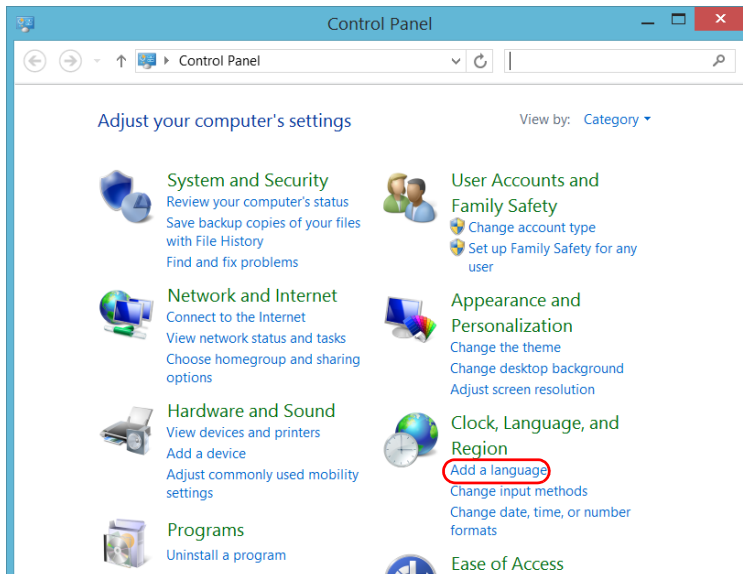

4. Select the desired language from the list.

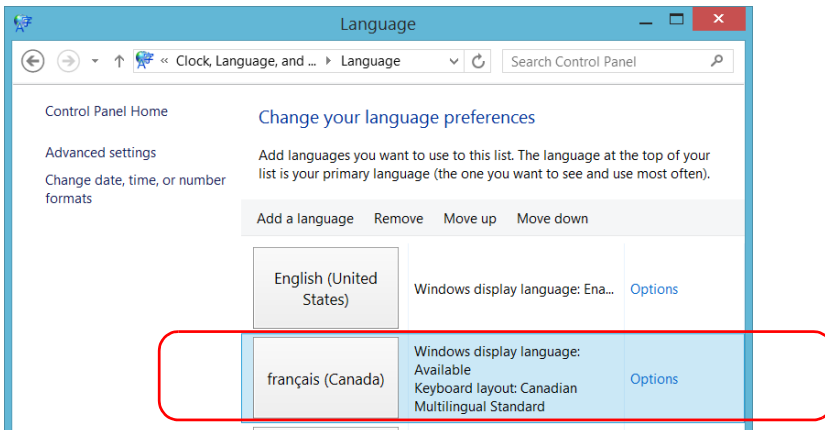

5. Tap **Options**.

6. If you want to select another keyboard layout than the one that has been added by default, proceed as follows.

- 6a. Under **Input method**, tap **Add an input method**.

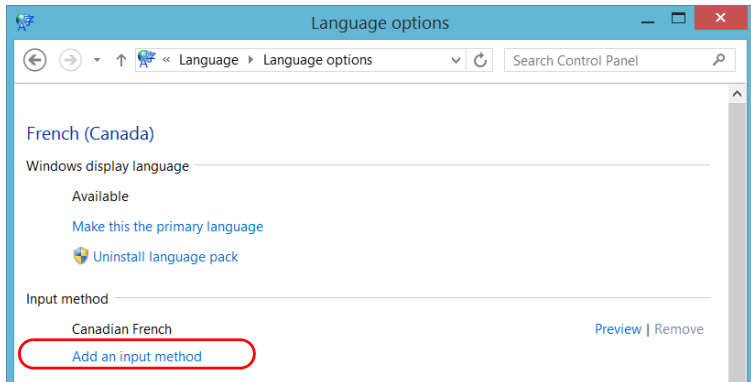

- 6b. Select the desired keyboard layout, and then tap **Add**.

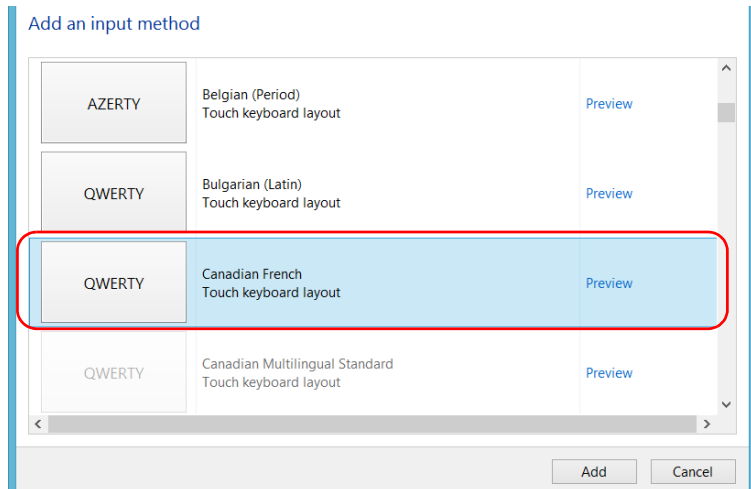

Setting Up Your FTB-2 and FTB-2 Pro

Selecting the Language of Operation

- Under **Windows display language**, tap **Make this the primary language**.

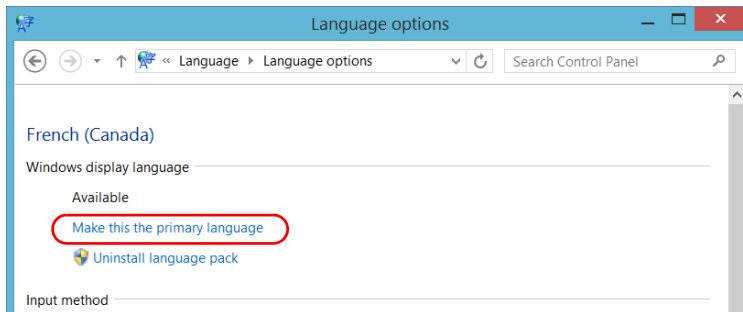

- When the application prompts you to log off, tap **Log off now**.
- Once you see the lock screen, swipe it down to reveal the user accounts.
- Log to your user account.

The new language is now selected and you are able to switch from one input language to another.



IMPORTANT

On an FTB-2, when you select a language that you have installed manually, the Windows interfaces do not switch to the selected language. They remain in the language configured at time of purchase. However, the EXFO applications are displayed in the selected language (when available).

To switch from one of the available input languages to another:

1. From the taskbar, tap the language code to display the list of available input languages.

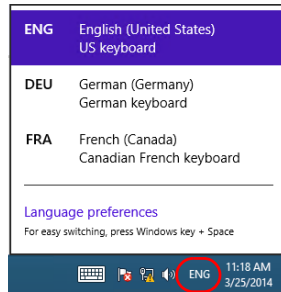

Language code

2. From the list of languages, select the desired one.

You are now ready to start entering text in the selected input language.

Note: *Modifying the input language does not modify the language of the interface.*

Setting Up Your FTB-2 and FTB-2 Pro

Selecting the Language of Operation

To download language packs:

1. Ensure that your unit has access to the Internet.
2. From the main window, tap the **System Settings** button.
3. Tap **Control Panel**.



4. Under **Clock, Language, and Region**, tap **Add a language**.

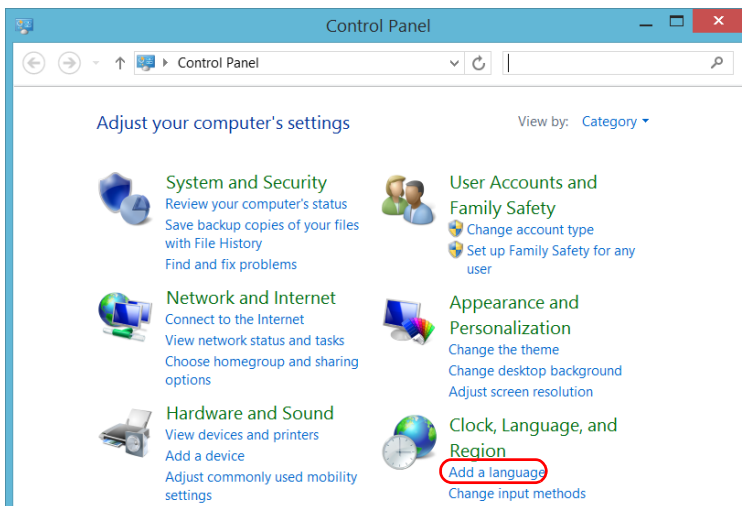

5. Tap **Add a language**.

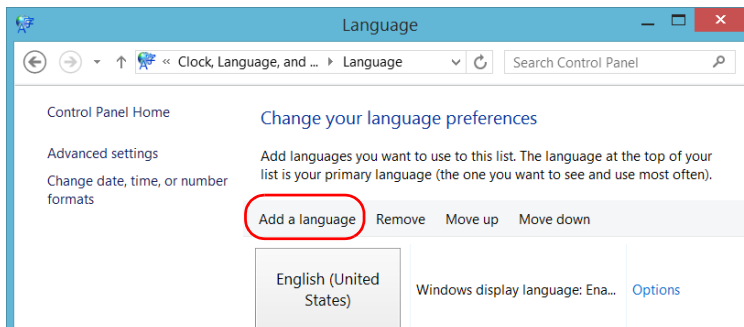

Setting Up Your FTB-2 and FTB-2 Pro

Selecting the Language of Operation

6. Browse the list of languages, and then select the one that you want to use.

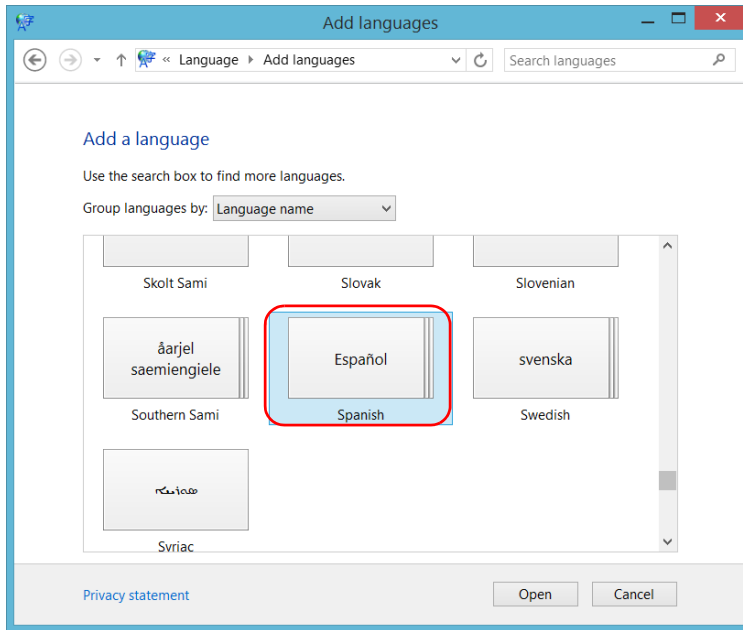

7. Tap **Open** to access the list of sub-languages.

8. Select the desired sub-language, and then tap **Add**.

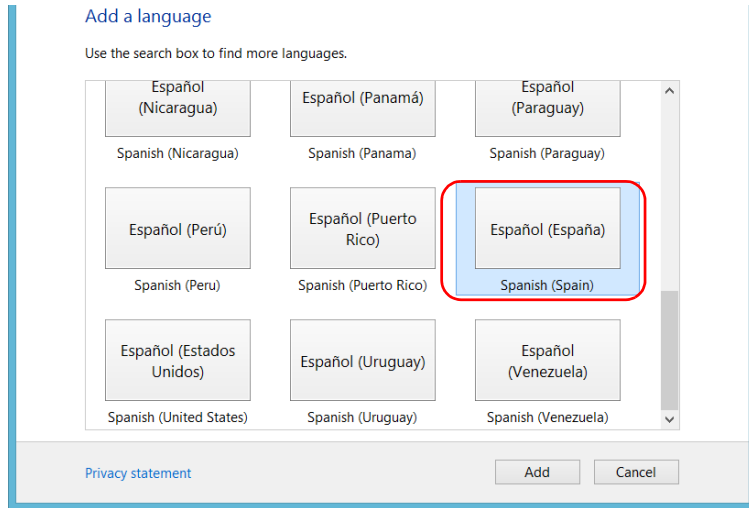

9. Select the desired language from the list.

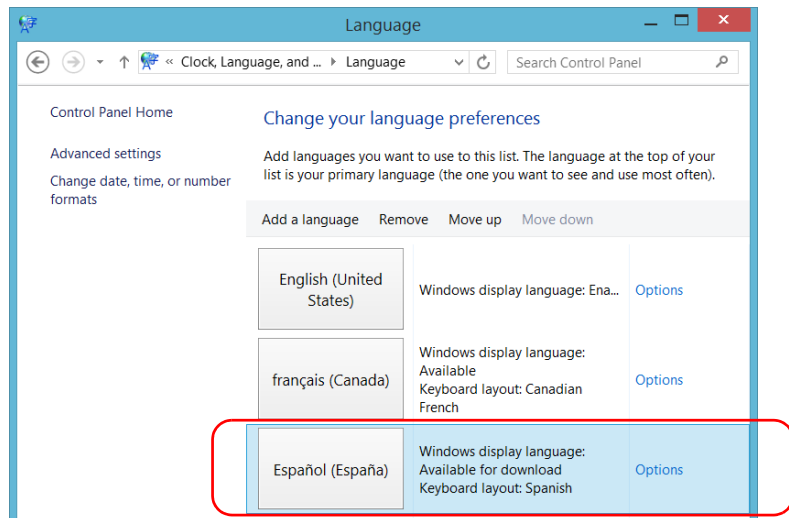

10. Tap **Options**.

Setting Up Your FTB-2 and FTB-2 Pro

Selecting the Language of Operation

11. Tap Download and install language pack.

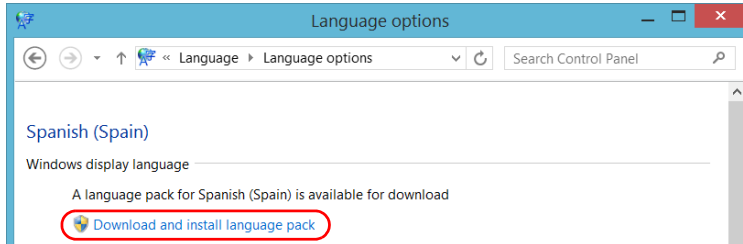

12. When the application prompts you to allow the installation, tap **Yes. The installation may take a few minutes.**

13. When the installation is complete, restart your unit.

Setting Date and Time Formats

By default, the dates (short and long) and time are displayed in the formats associated with the global language format (locale). The time can be expressed with a 12- or a 24-hour notation. You can modify the way dates and time are displayed if the default values do not suit your needs.

For information on how to adjust the date, the time, and the time zone, see *Adjusting the Date, Time and Time Zone* on page 111.

To set date and time formats:

1. From the main window, tap the **System Settings** button.
2. Tap **Control Panel**.



Setting Up Your FTB-2 and FTB-2 Pro

Setting Date and Time Formats

3. Under **Clock, Language, and Region**, tap **Change date, time, or number formats**.

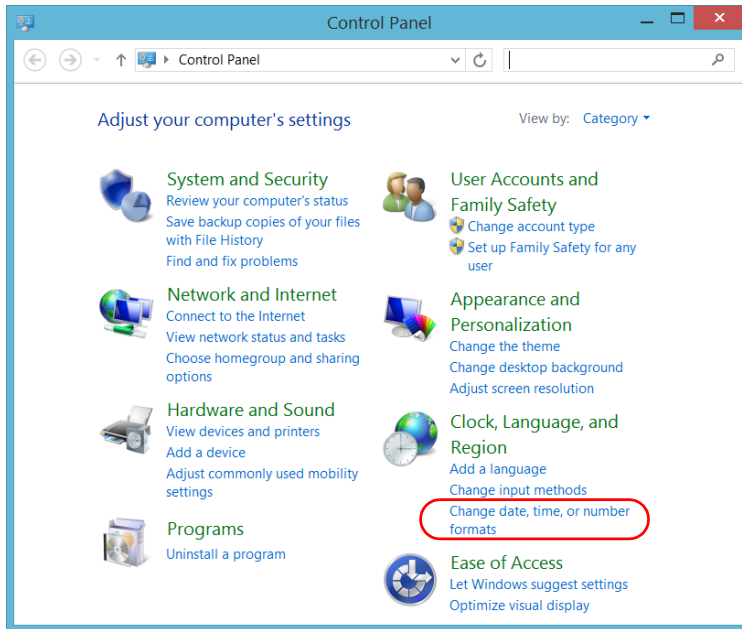

4. Refine the settings according to your needs.
5. Tap **Apply** to confirm, and then **OK** to close the window.

The new values are taken into account immediately.

Adjusting the Date, Time and Time Zone

Note: Only administrator-level users can adjust the date and time. All users can modify the time zone.

The current date and time are displayed at the bottom of the main window. When saving results, the unit also saves the corresponding date and time.

For information on how to modify the format in which the date and time are displayed, see *Setting Date and Time Formats* on page 109.

To adjust the date, time or time zone:

1. From the main window, tap the date and time displayed in the lower right corner of the screen.
2. Tap **Change date and time settings**.

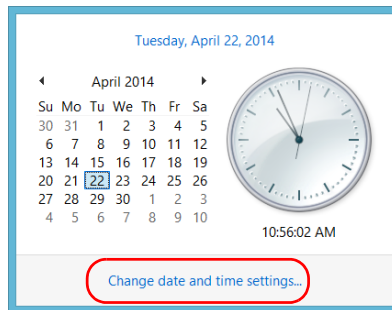

3. Modify the settings according to your needs.
4. Tap **Apply** to confirm, and then **OK** to close the window.

The new values are taken into account immediately.

Configuring the Power Management Options

To help you get the optimum performance out of your unit, it comes with predefined sets of parameters (plans) to manage power.

When you do not use the unit for a while, the display may be dimmed or turned off to save power. You can also configure the unit to go into sleep mode after the specified duration has expired (see *Turning Off Your Unit* on page 49).

For all of these actions, you can set idle durations for AC adapter/charger and battery operation. The values that you set are kept in memory even when you turn the unit off.

Note: *When the backlight is turned off and the  LED is lit and not blinking, the unit operation is not interrupted. Touch anywhere on the screen to return to normal operation.*

The table below identifies the predefined power plans.

Power Plan	Characteristics
Balanced (selected by default)	Provides extra power when your unit needs it, and saves power when your unit consumes less.
High Performance	Provides maximum power, which could be particularly useful when you intend to work modules requiring extra power.
Power Saver	Optimizes the energy consumption, which could be particularly useful when you operate the unit on batteries.

You can either modify one of the existing power plans or create one (based on an existing power plan). It is always possible to revert to factory default values for the predefined plans. You can delete custom power plans that you no longer use, but not the predefined plans.

To select a power plan:

1. From the main window, tap the **System Settings** button.
2. Tap **Control Panel**.



3. Tap **Hardware and Sound > Power Options**.

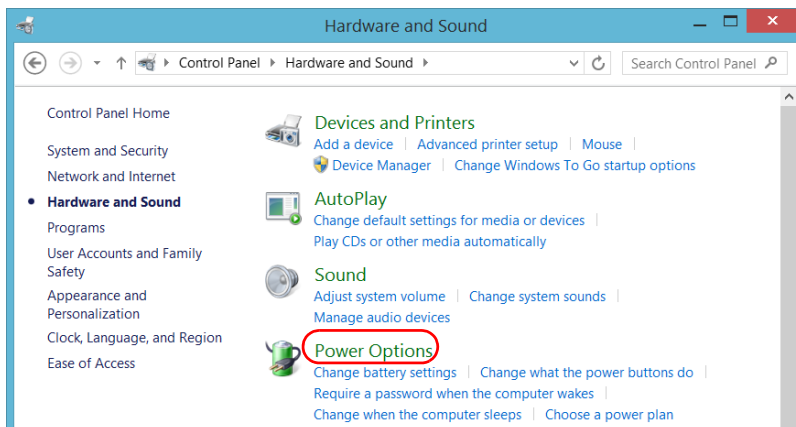

Setting Up Your FTB-2 and FTB-2 Pro

Configuring the Power Management Options

4. If necessary, tap **Change settings that are currently unavailable**.

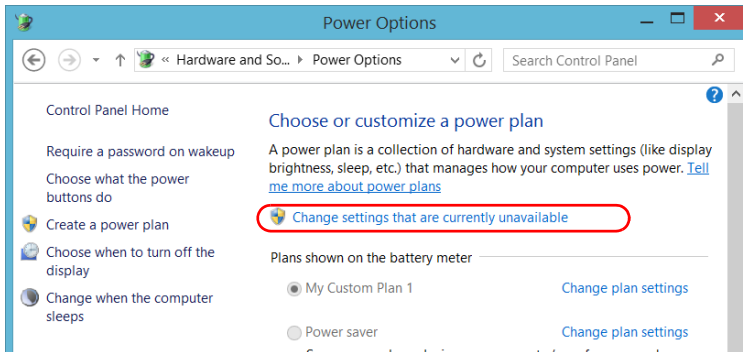

5. From the list of available power plans, select the desired set of parameters.

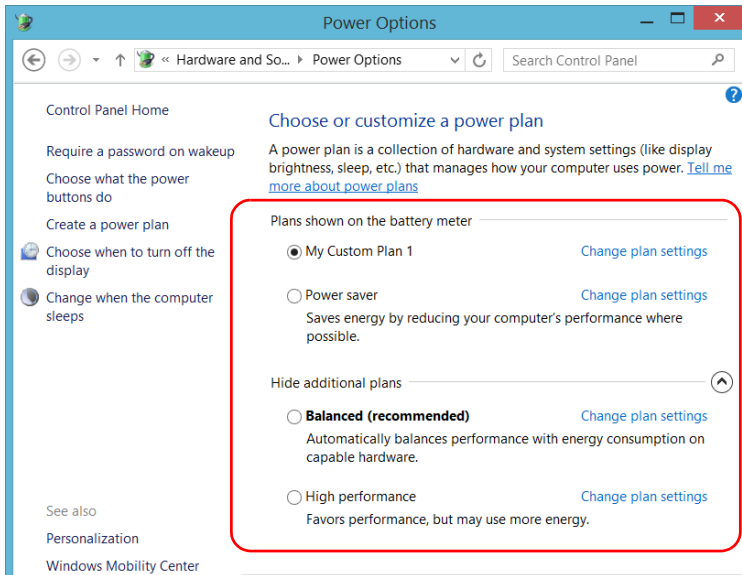

6. Close the window.

The new values are taken into account immediately.

To create a power plan:

1. From the main window, tap the **System Settings** button.
2. Tap **Control Panel**.

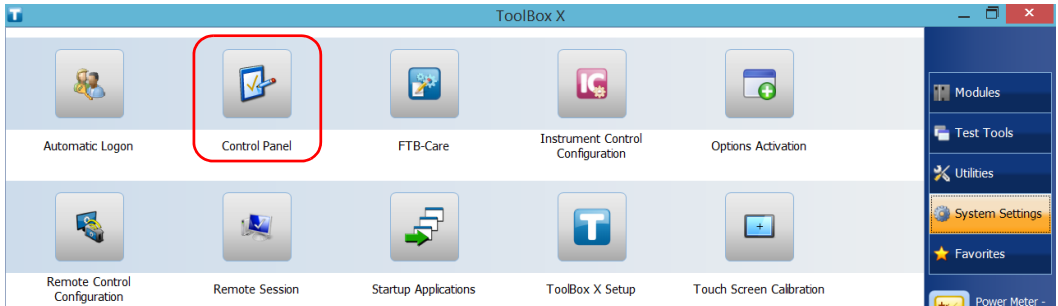

3. Tap **Hardware and Sound > Power Options**.

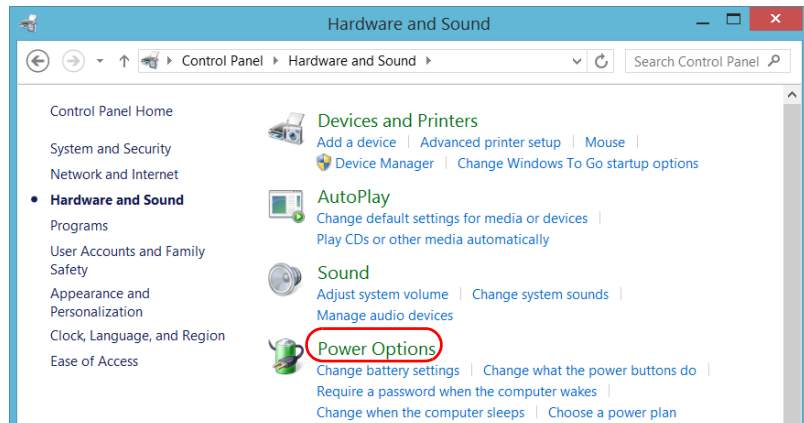

Setting Up Your FTB-2 and FTB-2 Pro

Configuring the Power Management Options

- From the list on the left, tap **Create a power plan**.

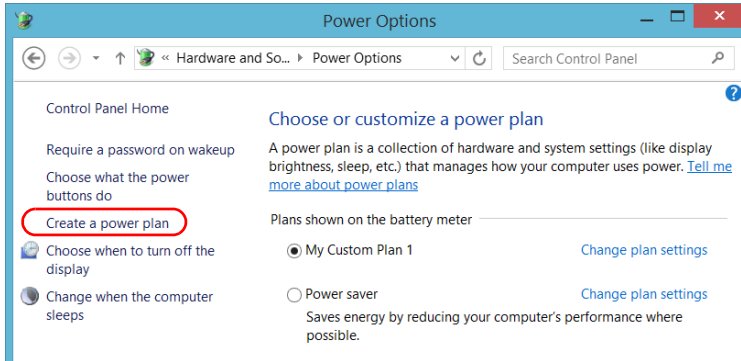

- Select a power plan that will serve as a basis.

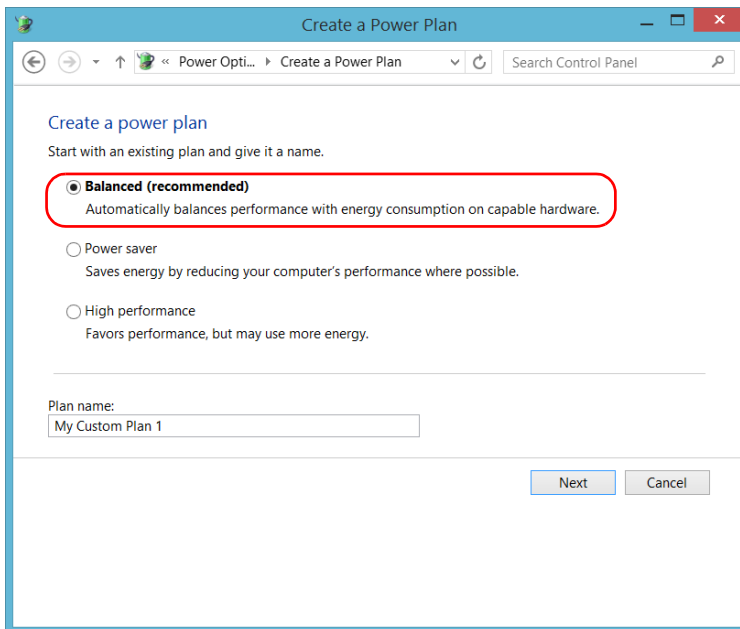

- Enter a name, and then tap **Next**.

7. Modify the parameters to suit your needs.

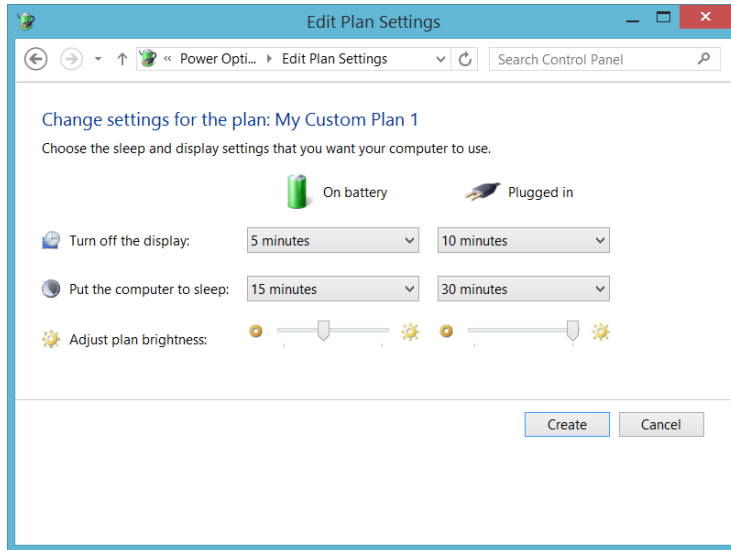

8. Tap Create.

Setting Up Your FTB-2 and FTB-2 Pro

Configuring the Power Management Options

To modify or delete an existing power plan:

1. From the main window, tap the **System Settings** button.
2. Tap **Control Panel**.

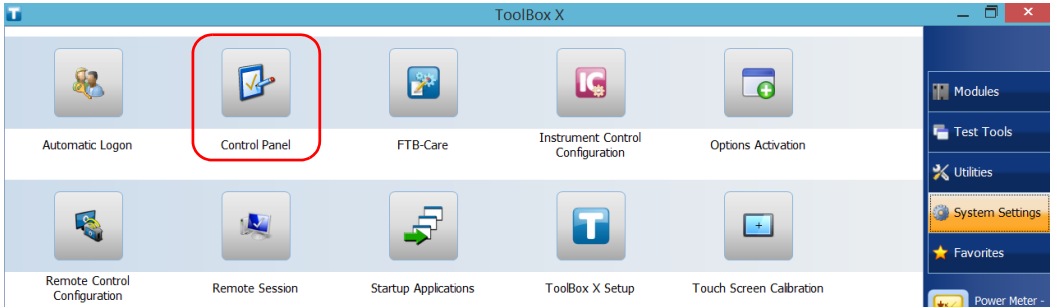

3. Tap **Hardware and Sound > Power Options**.

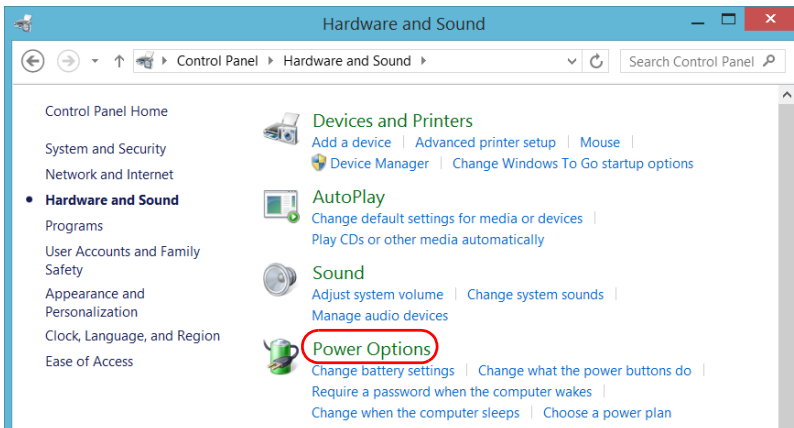

4. From the list of available power plans, locate the set of parameters that you want to modify or delete.

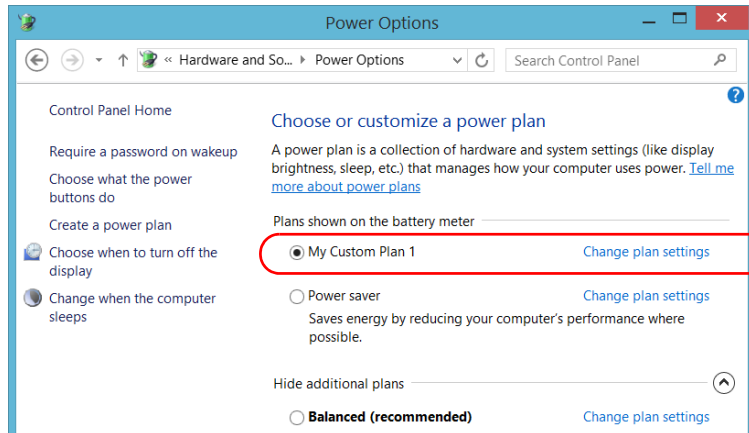

Note: *You can only delete custom power plans, not predefined ones. If the custom power plan that you want to delete is currently in use, you must select another plan first.*

5. Tap **Change plan settings** (appearing next to the power plan).

Setting Up Your FTB-2 and FTB-2 Pro

Configuring the Power Management Options

6. If you want to modify the parameters, proceed as follows:
 - 6a. If necessary, tap **Change settings that are currently unavailable**.

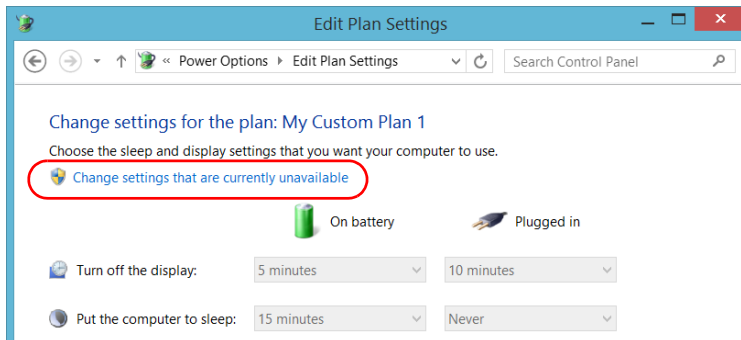

- 6b. Modify the parameters to your needs.

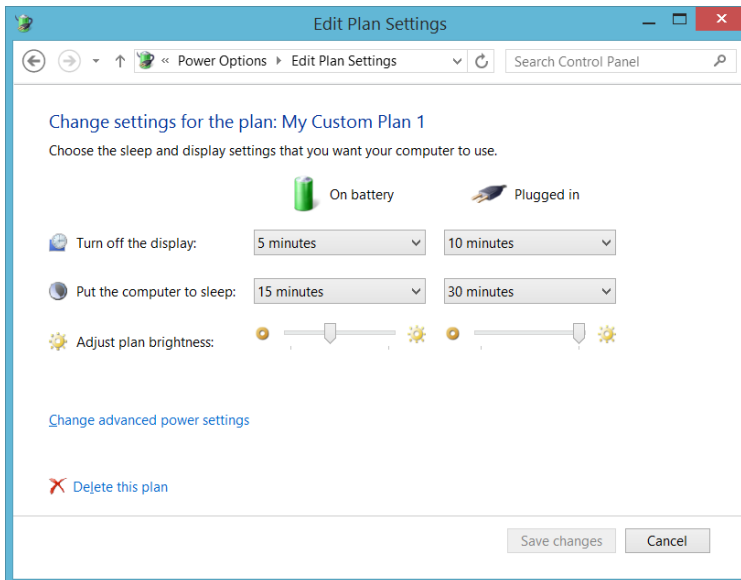

- 6c. Tap **Save changes**.

7. If you want to delete the power plan, tap **Delete this plan**, and then confirm the deletion.

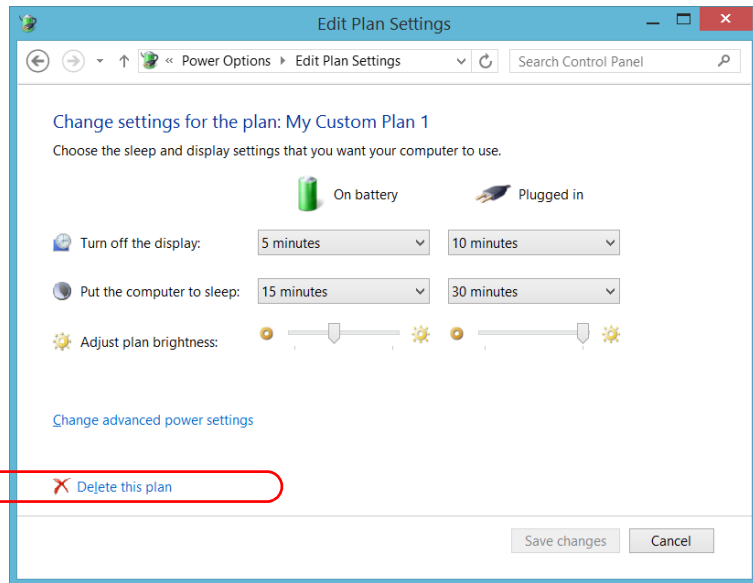

8. Close the window.

The changes are taken into account immediately.

Setting Up Your FTB-2 and FTB-2 Pro

Setting ToolBox X Behavior

Setting ToolBox X Behavior

You can specify how ToolBox X behaves when the application is started, minimized or closed.

To set the ToolBox X behavior:

1. From the main window, tap the **System Settings** button.
2. Tap **ToolBox X Setup**.

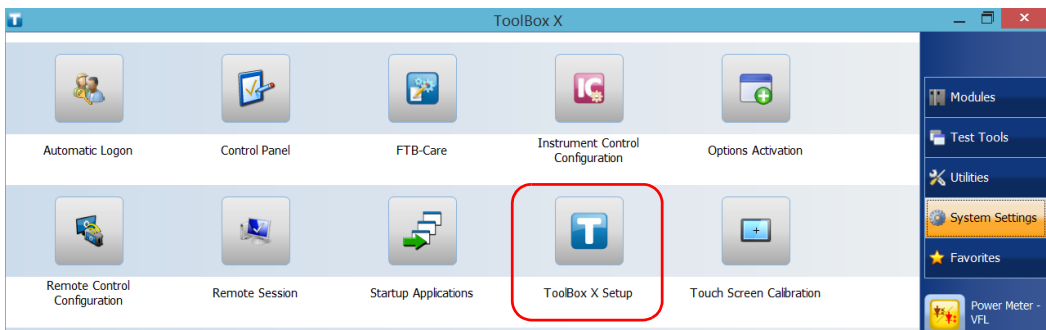

3. Select the items corresponding to the desired behavior.

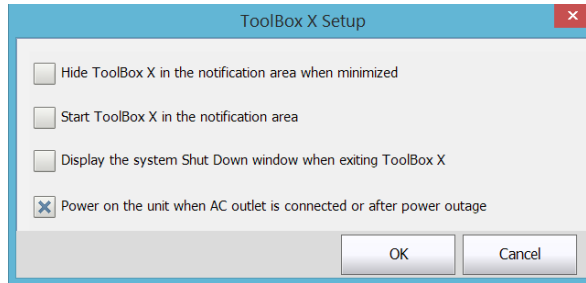

- **Hide ToolBox X in the notification area when minimized:** If this option is selected, the ToolBox X icon appears in the notification area (where the clock is located) when you minimize the window.
 - **Start ToolBox X in the notification area:** If this option is selected, ToolBox X is automatically started, then minimized to the notification area (system tray).
 - **Display the system Shut Down window when exiting ToolBox X:** If this option is selected, the standard system Shut Down window appears to let you shut down the unit directly instead of closing the ToolBox X application, then shutting down the unit from Windows. For more information on the different ways to turn off your unit, see *Turning Off Your Unit* on page 49.
4. Tap **OK** to confirm your settings and close the window.

Configuring the Internet Options

You can browse the Web directly from your unit, provided that you have access to an Internet connection and that the Internet options are configured properly.

If you are not sure about how you should configure your Internet access, contact your network administrator.

To configure the Internet options:

1. From the main window, tap the **System Settings** button.
2. Tap **Control Panel**.



3. Tap Network and Internet.

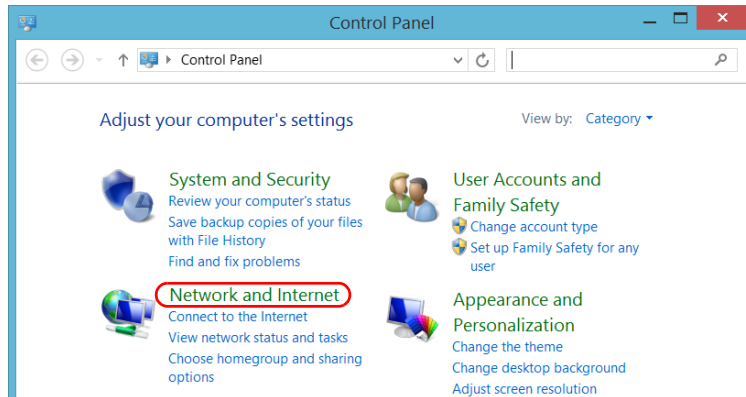

4. Tap Internet Options.

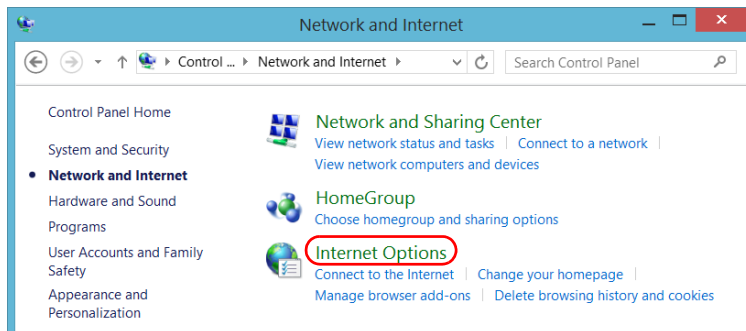

Setting Up Your FTB-2 and FTB-2 Pro

Configuring the Internet Options

5. Go to the **Connections** tab.

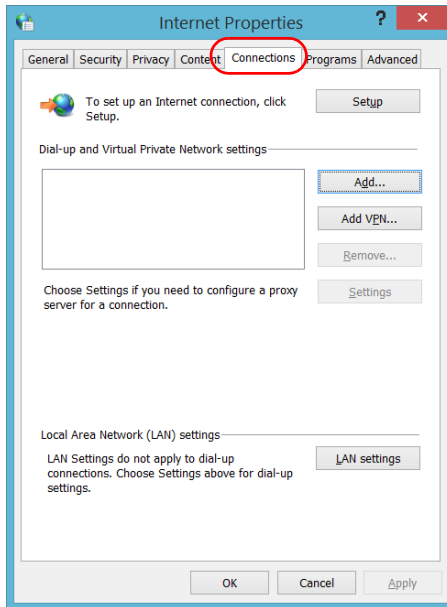

6. Modify the settings using the information provided by your network administrator.
7. Tap **OK** to return to the **Control Panel** window.

Configuring Parameters via Windows Mobility Center

For a quick access to various parameters such as the brightness, volume, or power plans, you may want to use the Windows Mobility Center.

To configure the parameters via Windows Mobility Center:

1. From the main window, tap the **System Settings** button.
2. Tap **Windows Mobility Center**.

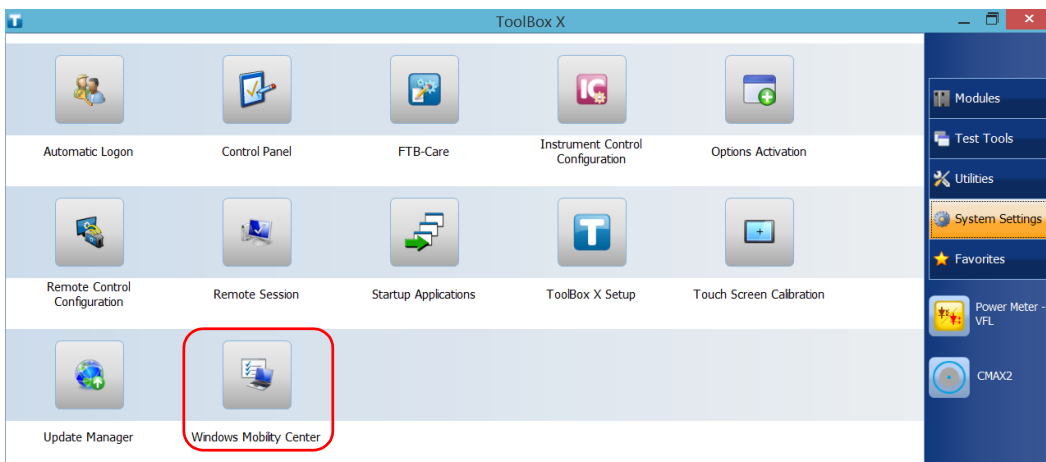

Setting Up Your FTB-2 and FTB-2 Pro

Setting Other Parameters

3. Set the parameters as desired.

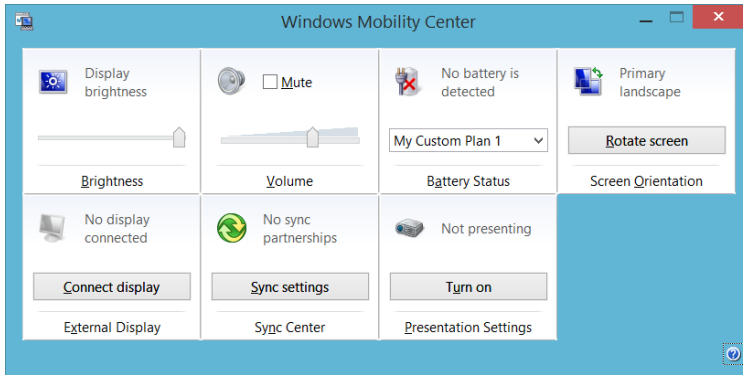

Setting Other Parameters

You can also configure many other parameters via the **Control Panel** window. Refer to Microsoft 8.1 Pro or Windows Embedded 8 Standard documentation for details.

5 Working with Your Unit

Printing Documents

You can print documents and images directly from your unit by using either the provided PDF creation tool or an external printer (for printing on paper).

You can view the PDF files from your unit, using the provided PDF reader. For more information, see *Viewing PDF Files* on page 130.

You can use a local or a network printer to print on paper.

- Local printer: You must connect the printer to your unit and install the required software and drivers provided by the manufacturer of the printer.
- Network printer: Your unit must be accessible from this network by Wi-Fi or standard Ethernet. You must also define the printer on your unit before attempting to access it (see *Configuring Network Printers* on page 96).

Note: *Some applications may not offer print functions.*

To print documents:

1. Open the document that you want to print.
2. From the application in which you have opened your file, access the print function.

Note: *In most applications, you can access the print function by the **File** menu or by a **Print** button.*

3. Select the desired printer (PDF creation tool by default).
4. If necessary, adjust the printer's parameters to your needs.
5. Tap **Print** to start the printing process, and follow the on-screen instructions.

Working with Your Unit

Viewing PDF Files

Viewing PDF Files

You can view PDF files directly from your unit using the provided PDF file viewer. For more information on the available features for this viewer, refer to the PDF viewer online help.

Note: *You may need a connection to the Internet to access the PDF viewer online help.*

Note: *On the FTB-2 Pro, you can also you use any PDF viewer that you like, as long as it is compatible with Windows 8.1 Pro (not possible to install third-party PDF viewers on FTB-2 units).*

To view PDF files:

1. From the main window, tap the **Utilities** button.
2. Tap **File Manager**.

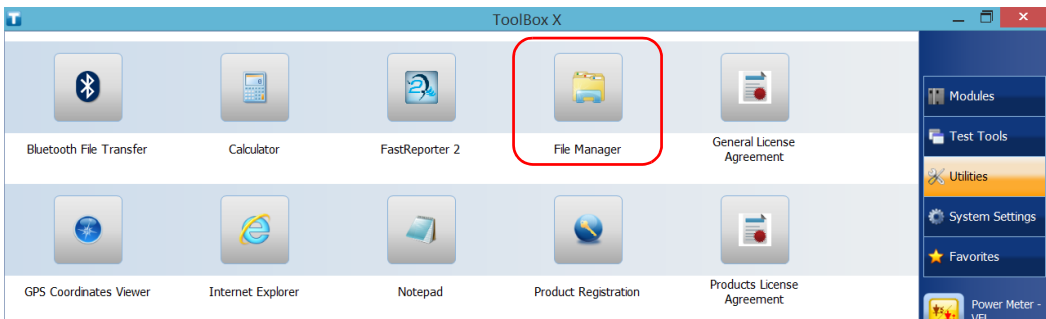

3. Browse through the folders to find the desired PDF file.
4. Double-tap the file.
5. The file opens automatically in the PDF viewer.

Taking Screen Captures

You can take captures of what is displayed on your screen, directly from your unit. This could be useful for troubleshooting when you need another person to have a look at a specific configuration or problem. You could also use this tool for training purposes.

If you want to capture images of the fibers that you examine with the fiber inspection probe, you can use the capture feature of the probe instead.

- The images are saved in .png format. They are sent to the following folder (in the account of the user currently logged on the unit):

This PC\Pictures\Screenshots

- The application generates file names as follows:

Screenshot (<Sequential_number>).png

where

Sequential_number corresponds to the number that is added each time you take a screen capture.

Note: *The name of the folders and of the files described above will vary according to the language that is currently selected in Windows.*

To take a screen capture:

From the unit's front panel, press the  button and hold it down for a few seconds.

The screen capture is automatically taken (a visual effect typical of a camera taking a picture indicates that the capture is complete).

Note: *If a keyboard is connected to your unit, you can also press the Windows logo key + PRINT SCREEN.*

Browsing the Web

You can browse the Web directly from your unit, provided that you have access to an Internet connection.

If you need to modify the Internet options, see *Configuring the Internet Options* on page 124. For more information on how to connect to the Internet using a 3G USB modem key, see *Accessing the Internet with a 3G USB Modem Key* on page 133.

To browse the Web:

1. Open a Web browser as follows:
 - 1a. From the main window, tap the **Utilities** button.
 - 1b. Tap the **Internet Explorer** icon to open the browser.
2. Enter the desired Web address in the address bar and tap the  button (located at the right of the address bar) to start browsing.

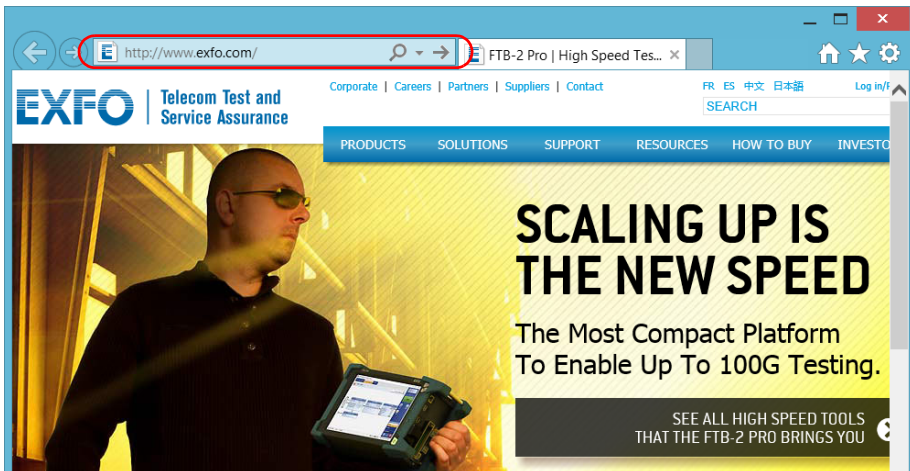

3. Close the window to return to the **Utilities** window.

Accessing the Internet with a 3G USB Modem Key

Note: *Only administrator-level users can install software. However, when the installation is complete, all users will have the possibility to access the Internet with a USB modem key.*

You can connect a 3G USB modem key to your unit to have a wireless access to the Internet.

You need to use a 3G modem key equipped with an unlocked and activated Subscriber Identity Module (SIM) card (you must subscribe to a package of mobile services). If you need more information on the 3G coverage in your area, contact your provider of mobile services.

Usually, you have to install an application with which you will establish a connection with the mobile network whenever you want to work with your USB modem key. Most of the time, this application is installed automatically the very first time you connect a USB modem key to your unit. In all cases, you only need to install this application once.

Working with Your Unit

Accessing the Internet with a 3G USB Modem Key

To work with a 3G USB modem key:

- 1.** If necessary, turn on your unit and wait for the startup sequence to complete.
- 2.** If necessary, connect the USB modem key to one of the USB ports of your unit.
- 3.** Start the application allowing you to establish a connection to the mobile network.
- 4.** Once the application starts, connect to the mobile network.

As soon as the connection is established, you are ready to browse the Web.

Note: *Depending on the package that you have purchased with your service provider and the type of network, you may have to set specific parameters. If you are not sure on how to proceed or need more information about the configuration, contact your service provider.*

- 5.** When you have finished working, disconnect from the mobile network, and then remove the USB modem key from your unit.

Managing Favorites

For a quicker access to the applications that you use most often, you may want to build your own list of favorite applications (Favorites).

You can add and remove Favorites from the list. You can also import and export lists of Favorites, which could be useful for backup and recovery purposes, or to share the same Favorites among several units.

Note: *To have access to the same Favorites on several units, the corresponding applications must be available on all units.*

To add Favorites:

1. From the main window, tap the **Favorites** button.
2. Tap **Favorites Management**.

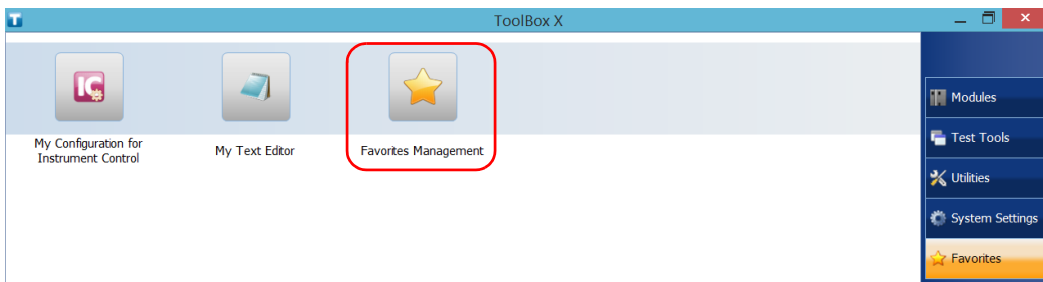

3. Tap **Add**.

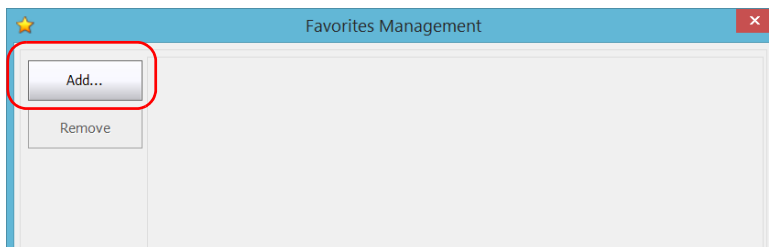

Working with Your Unit

Managing Favorites

4. Tap **Browse** to locate the desired application.

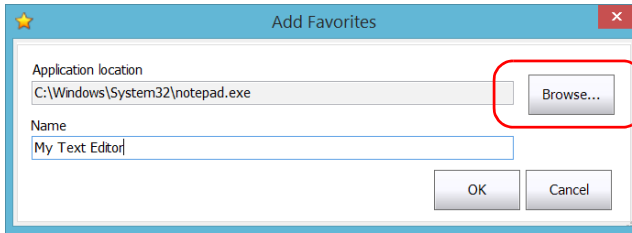

5. Type a name for the new Favorite.
6. Tap **OK** to confirm the location and name.
7. Repeat the previous steps with all the Favorites that you want to add.
8. Tap **OK** to apply the changes and close the window.

To remove Favorites:

1. From the main window, tap the **Favorites** button.
2. Tap **Favorites Management**.

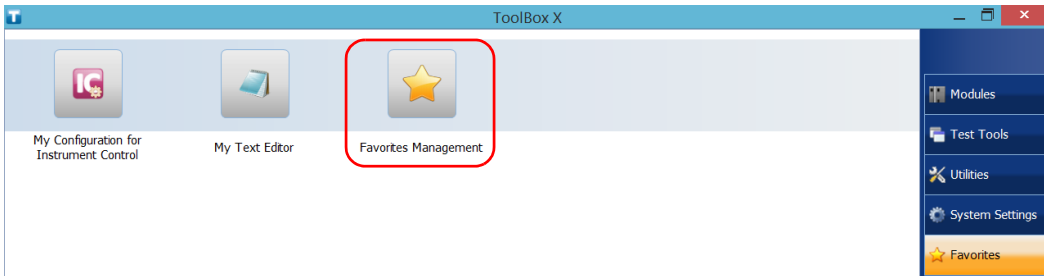

3. Tap the icon corresponding to the Favorite that you want to remove from the list.

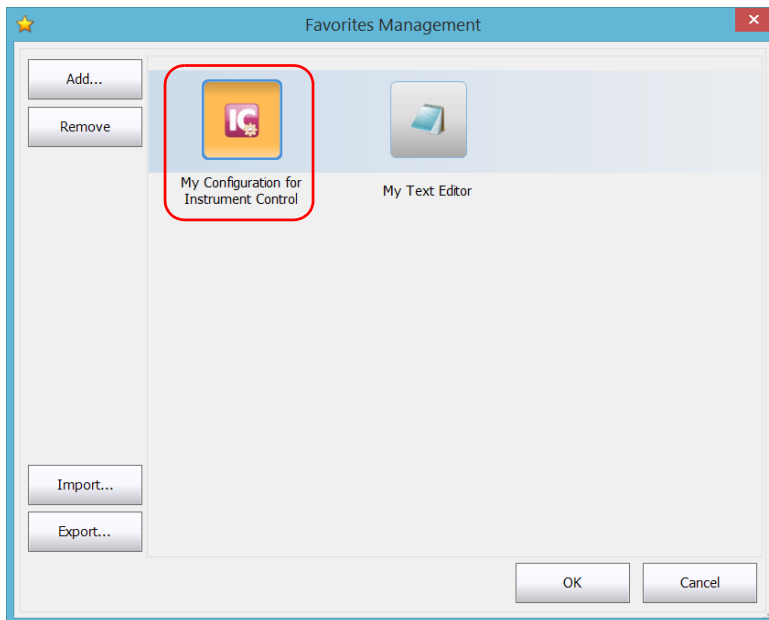

4. Tap **Remove**.

Note: *The application will not prompt you to confirm the removal of the Favorite from the list. Removing a Favorite from the list does not uninstall the application from the unit.*

5. Tap **OK** to apply the changes and close the window.

Working with Your Unit

Managing Favorites

To work with Favorites:

1. From the main window, tap the **Favorites** button.
2. Tap the icon corresponding to the application that you want to use.

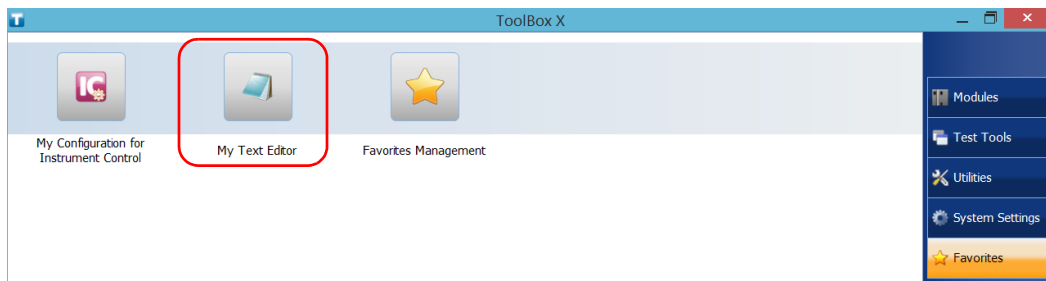

To export the list of Favorites:

1. From the main window, tap the **Favorites** button.
2. Tap **Favorites Management**.

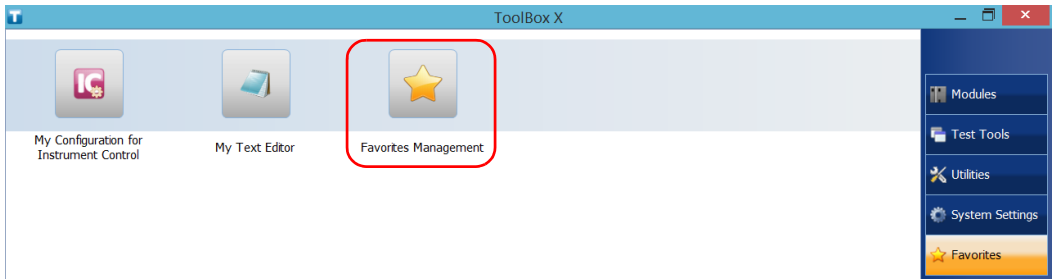

3. Tap **Export**.

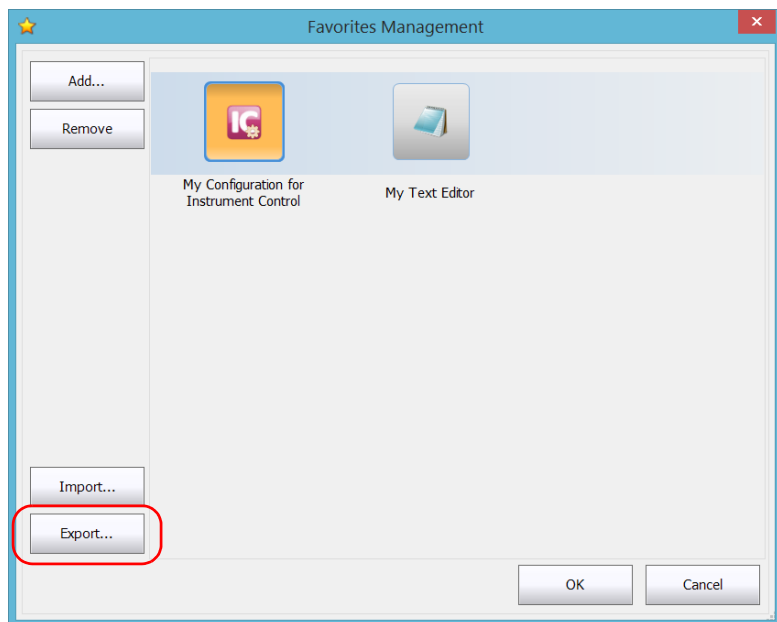

Working with Your Unit

Managing Favorites

4. Select a location and type a name for the Favorites list.

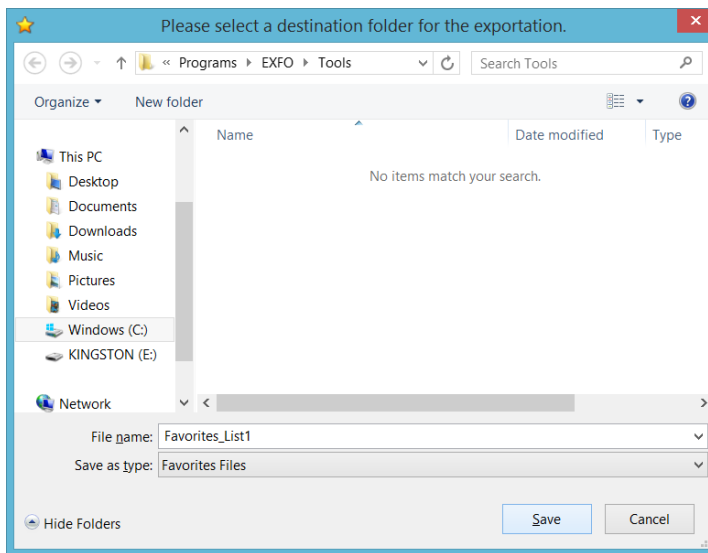

5. Tap **Save**.
6. Tap **OK** to apply the changes and close the window.

To import a list of Favorites:

1. From the main window, tap the **Favorites** button.
2. Tap **Favorites Management**.

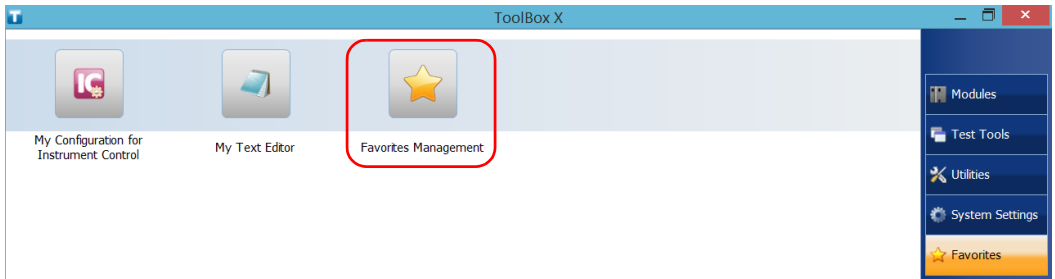

3. Tap **Import**.

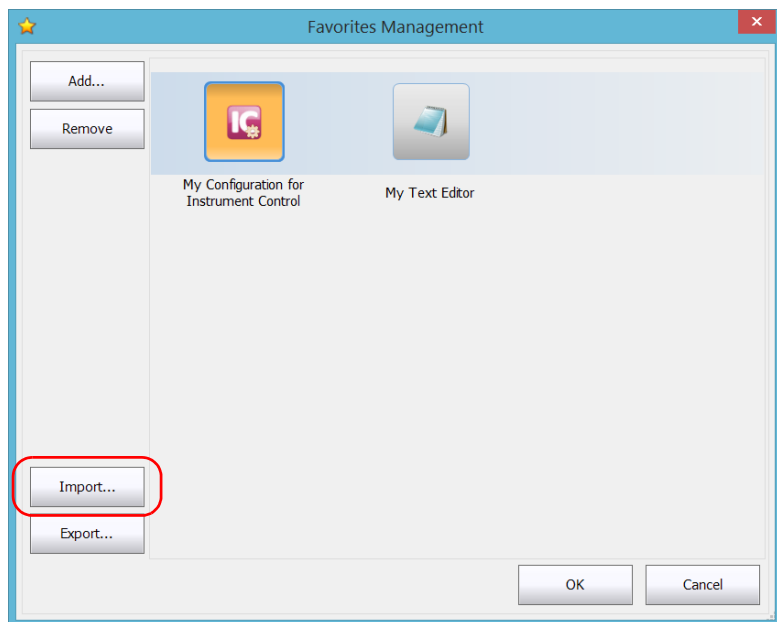

Working with Your Unit

Managing Favorites

4. Select the desired Favorites list.

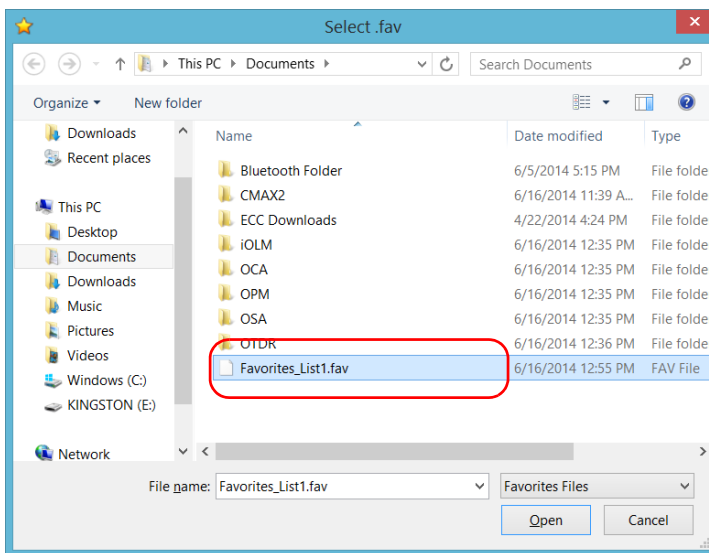

5. Tap **Open**.
6. Tap **OK** to apply the changes and close the window.

Using the Calculator

You can use Microsoft Calculator directly from your unit.

To use the Calculator:

- 1.** From the main window, tap the **Utilities** button.
- 2.** Tap **Calculator**.

Using the Text Editor

You can use Microsoft Notepad directly from your unit.

To use the text editor:

- 1.** From the main window, tap the **Utilities** button.
- 2.** Tap **Notepad**.

Working with Your Unit

Accessing Other Tools

Accessing Other Tools

Your unit comes with various tools that can help you better analyze or manage your data.

You have also access to free tools such as Wireshark to help you troubleshoot networks. For more information, refer to the online help provided with these tools, when applicable.

To access the applications:

1. From the main window, tap the **Test Tools** button.

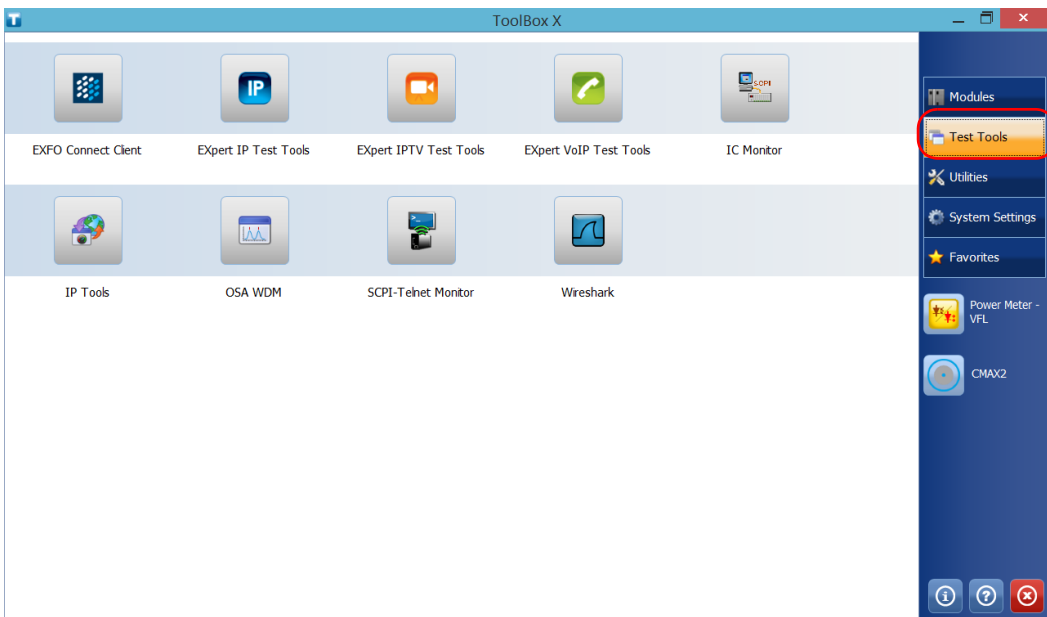

2. Tap the icon corresponding to the application that you want to start.

6 ***Using the Optional Built-In Power Meter and VFL***

The FTB-2 and FTB-2 Pro can be equipped with an optical power meter and a visual fault locator (VFL).

With the power meter, you can measure absolute power (dBm or W) or insertion loss (dB). The power meter can detect modulated signals (1 kHz, 2 kHz, and 270 Hz). With the VFL, you can inspect or identify fibers. For more information on how to use the power meter or the VFL, refer to the power meter online help.



IMPORTANT

If you intend to take measurements with a very low power level, make sure that your testing conditions are optimal to ensure the best results (for example, do not use the VFL, make sure that the other modules in your platform are not performing measurements and that their internal parts are not moving, etc.).

Using the Optional Built-In Power Meter and VFL

To access the built-in power meter or the VFL:

From the main window, tap **Power Meter and VFL**.

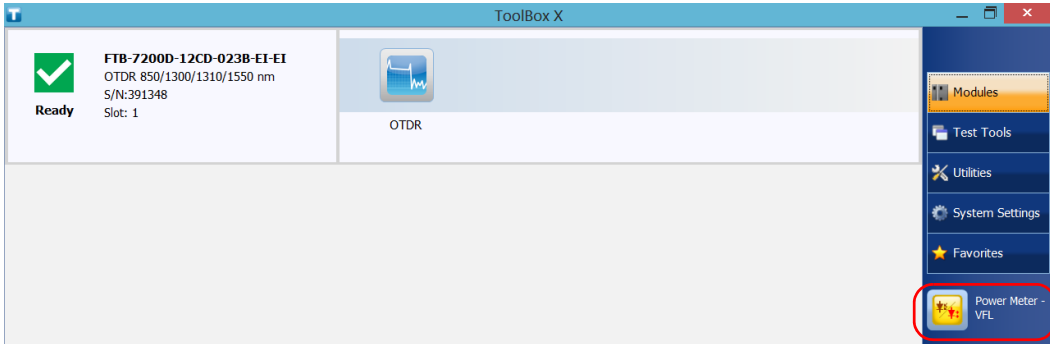

Note: The **Power Meter and VFL** button is only visible if your unit is equipped with a power meter and a VFL.

Note: You can access the online help of the power meter and the VFL by tapping the  button from the power meter application.

7 *Inspecting Fibers with a Probe*

The fiber inspection probe (FIP) is used to find dirty or damaged connectors by displaying an enlarged view of the connector surface. You can connect an FIP to your unit to view fiber ends.



IMPORTANT

Only the probes of the FIP-400B series are supported on your unit.

Fiber inspections are made using the ConnectorMax2 application. For more information, refer to the ConnectorMax2 online help.

To inspect fibers with a probe:

1. Connect the probe to one of the USB ports of your unit (right or top panel).
2. From ToolBox X, tap the **ConnectorMax2** button to open the application.

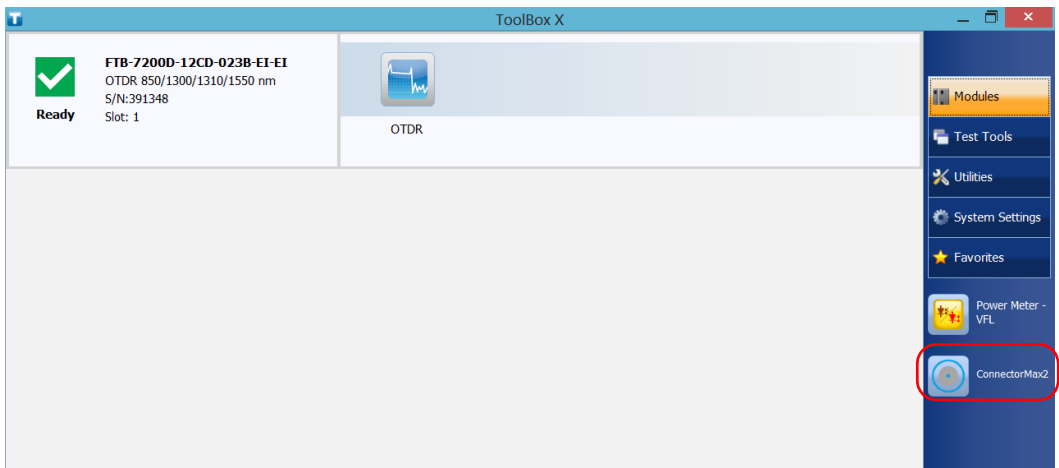

Note: You can access the online help by tapping the  button from the ConnectorMax2 application.

8 ***Managing Data***

You can copy, move, rename, delete files and folders directly on your unit.

You can transfer files from your unit to a USB memory key or a computer. You can also transfer data from a storage device or a computer to your unit.

Your unit is equipped with the following ports and devices for data transfer:

- Two USB 2.0 ports and one USB 3.0 port to connect a memory key
- an Ethernet port to connect to a network (for transfer via VNC or Remote Desktop - see *Accessing Your Unit Remotely* on page 185)
- internal Wi-Fi and Bluetooth module (optional) to connect to a wireless network or transfer data via Bluetooth

Managing Data

Viewing Disk Space and Managing Files

Viewing Disk Space and Managing Files

To help you manage the data that is stored on your unit, you can easily view the remaining disk space. You can also copy, move, rename, delete files and folders directly from your unit.

To view the free disk space, and manage files and folders:

1. From the main window, tap the **Utilities** button.
2. Tap **File Manager**.

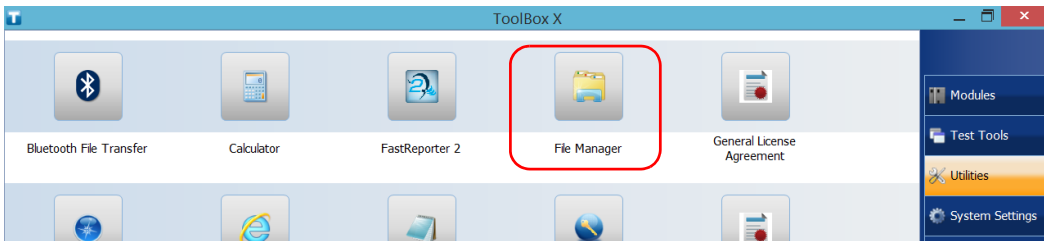

The file explorer is displayed.

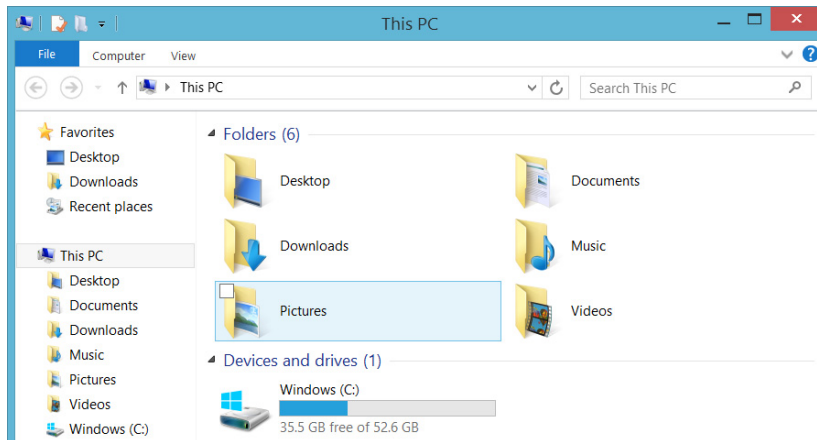

Note: The free disk space is also visible from the **Platform** tab (tap  in the lower right corner of the main window).

Transferring Data via Bluetooth

If you have purchased the Wi-Fi and Bluetooth option, you can transfer data between your unit and a computer (or another device such as a smartphone) using the Bluetooth technology. In all cases, you must ensure that the computer or the device is Bluetooth-compatible and configured properly.

Note: *Some Bluetooth-compatible devices only allow data transfer between devices of the same manufacturer. In this case, you will need to use another type of device or a standard computer to transfer data from your unit.*

Your unit must be located within a 10-meter area from your computer (limitation of the Bluetooth Class 2 devices).

Since transfer speed is limited for larger files (more than 1 GB), if you need to transfer such files, you may want to use a USB key, or connect to a Wi-Fi or an Ethernet network.



IMPORTANT

Depending on the operating system that your computer is running (or on the smartphone that you are using), it is possible that only data transfer secured with a passkey be allowed.

The procedure presented hereafter explains how to transfer data from your unit to a computer.

Note: *If you transfer files from a computer to your unit, they will be sent automatically to the This PC\Documents\Bluetooth Folder on your unit.*

Managing Data

Transferring Data via Bluetooth

To configure your unit and the computer for transfer:

1. Configure your unit as follows:

1a. From the notification area, tap the Bluetooth icon.



1b. Tap **Open Settings**.

1c. From the **Options** tab, under **Discovery**, select the **Allow Bluetooth devices to find this PC** check box.

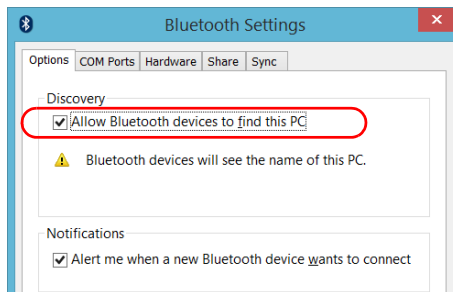

- 1d.** From the **Share** tab, ensure that the **Allow remote devices to browse, send, and receive pictures, music, and other files** check box is selected.

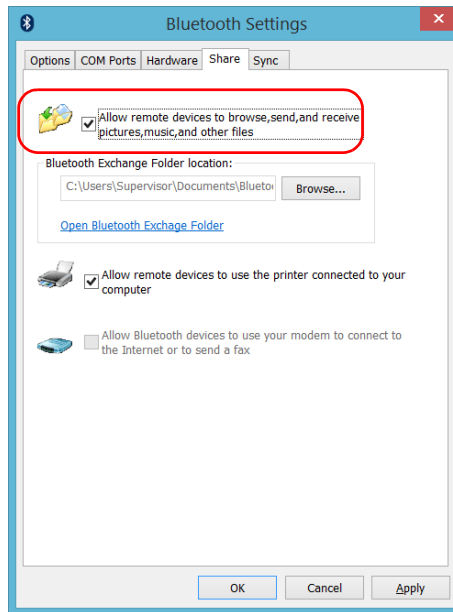

- 1e.** Tap **OK** to confirm.
- 2.** Configure the computer as follows:
 - 2a.** From the notification area, click the Bluetooth icon.
 - 2b.** Select **Open Settings**.
 - 2c.** Ensure that the option allowing Bluetooth devices to find the computer is selected.
 - 2d.** Click **OK** to confirm.

Managing Data

Transferring Data via Bluetooth

To transfer data via Bluetooth:

- 1.** Pair your computer with your unit as follows.
 - 1a.** On your unit, from the right side of the screen, swipe left to display the Charm bar.
 - 1b.** Tap **Settings** > **Change PC settings**.

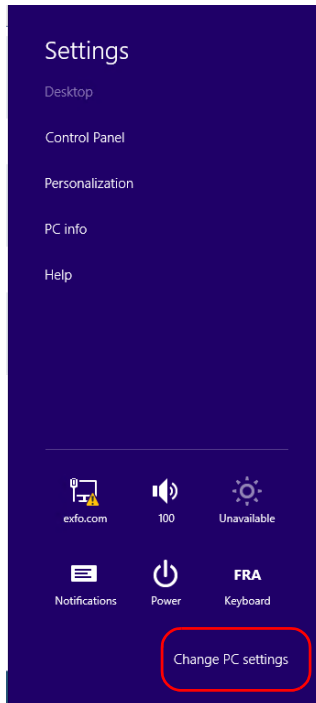

- 1c.** On an FTB-2 Pro, tap **PC and devices**.
On an FTB-2, tap **Devices**.

FTB-2 Pro

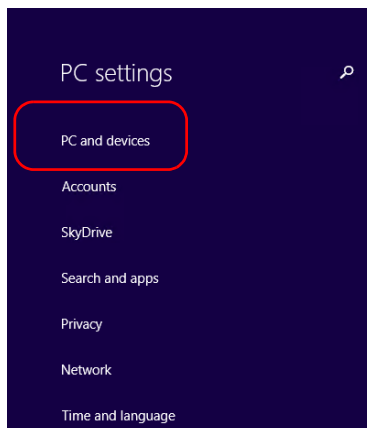

Personalize



FTB-2

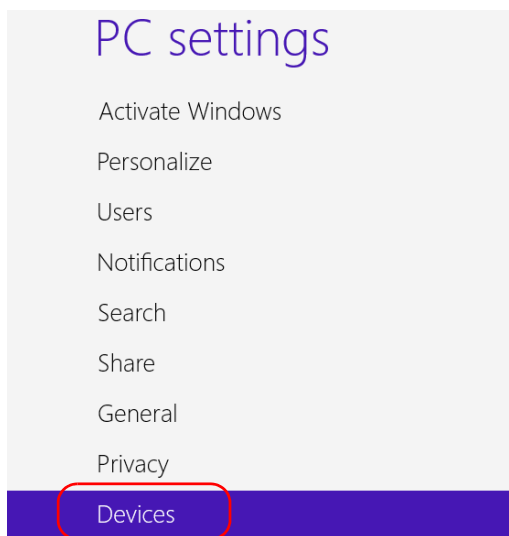

Devices

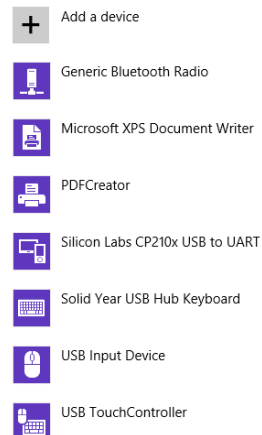

Managing Data

Transferring Data via Bluetooth

- 1d.** On an FTB-2 Pro, tap **Bluetooth**.
On an FTB-2, tap **Add a device**.

FTB-2 Pro

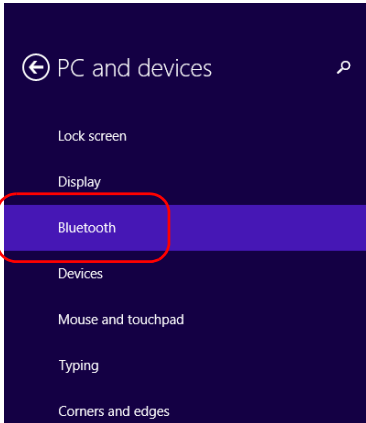

Manage Bluetooth devices

Your PC is searching for and can be discovered by Bluetooth devices.

- LAPQC00371
Ready to pair
- LAPQC04930
Ready to pair
- LAPQC05075
Ready to pair
- LAPQC4903
Ready to pair
- WKSQC05152
Ready to pair

FTB-2

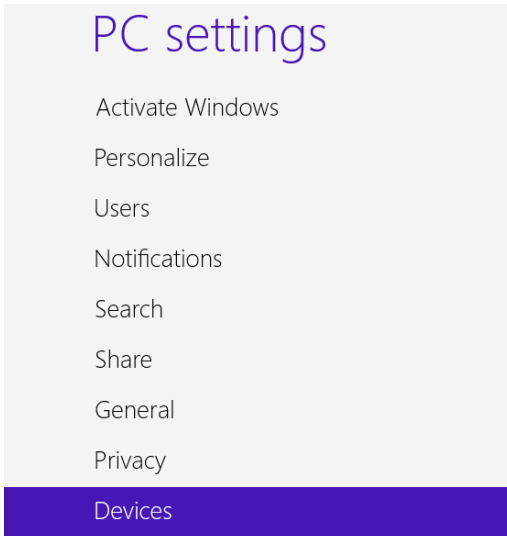

Devices

- + Add a device**
- Generic Bluetooth Radio
- Microsoft XPS Document Writer
- PDFCreator
- Silicon Labs CP210x USB to UART
- Solid Year USB Hub Keyboard
- USB Input Device
- USB TouchController

- 1e.** From the list of Bluetooth devices, tap the item corresponding to the computer to which you want to transfer files.

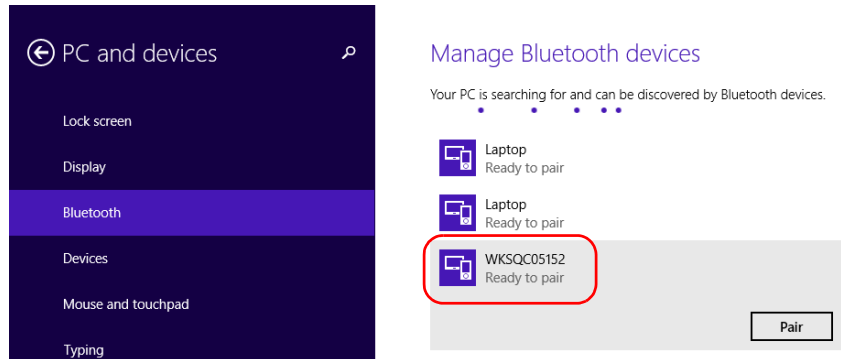

- 1f.** On the FTB-2 Pro, tap **Pair**. On the FTB-2, the application tries to establish the pairing automatically.

Note: *If the computer or device that you want to select is already paired, you must remove the pairing first with the **Remove device** button. On FTB-2, you must first tap the  button to view the **Remote device** button.*

Note: *Depending on the computer that you are using, the application will either provide you with a passkey, or prompt you to confirm that the displayed passkey matches the passkey used on the computer.*

- 1g.** If necessary, write down the provided passkey.
- 1h.** On the computer, when the application prompts you, click the Bluetooth icon (located on the taskbar) to display the wizard allowing you to add a Bluetooth device.
- 1i.** Follow the on-screen instructions. Enter the passkey that you wrote down earlier, or confirm the correspondence between the two passkeys.

Managing Data

Transferring Data via Bluetooth

2. Transfer the files as follows.
 - 2a. From the main window, tap the **Utilities** button.
 - 2b. Tap **Bluetooth File Transfer**.

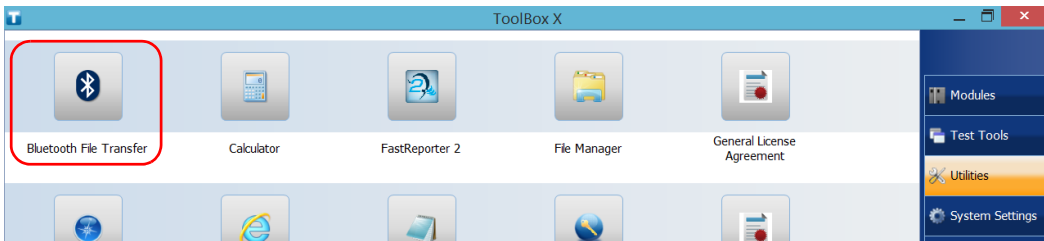

- 2c. Select **Send files**.

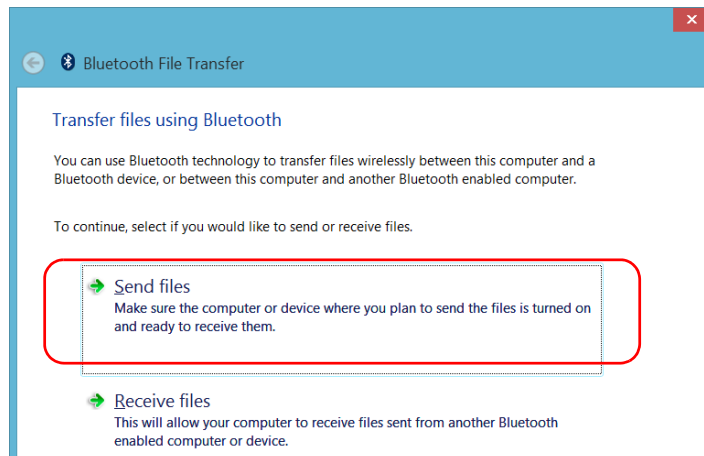

2d. Select the desired computer, and then tap **Next**.

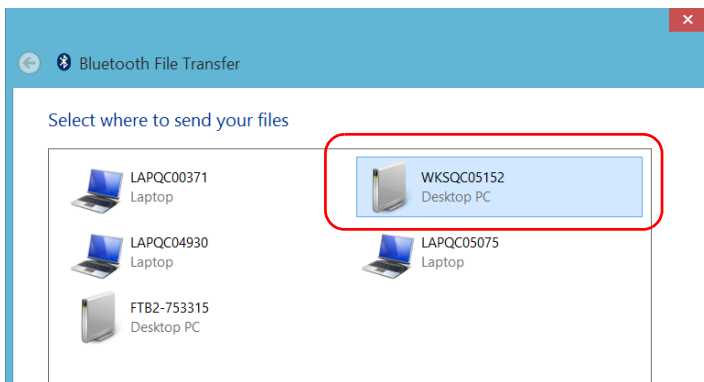

2e. Tap the **Browse** button to select the file that you want to transfer, and then tap **Next**.

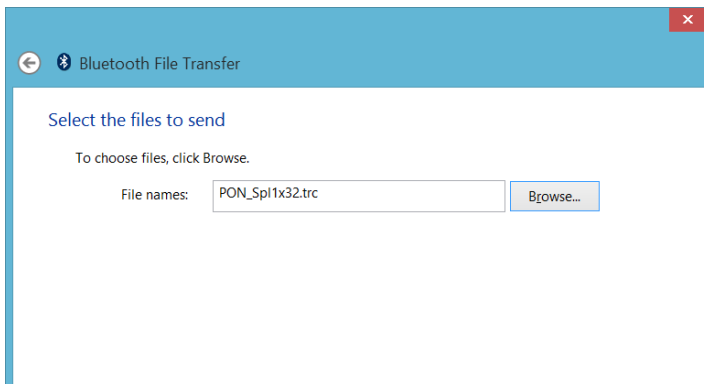

2f. Tap **Finish** when the transfer is complete.

Connecting to a Wireless Network

If you have purchased the Wi-Fi and Bluetooth option, you can connect to a wireless network and benefit from all resources that are available on this network. You can transfer data exactly as you would do from an Ethernet network. By default, the internal wireless module is enabled, but not connected to a network.

If you have disabled the Wi-Fi device, you must enable it before trying to connect to a wireless network (see *Enabling or Disabling the Wireless Communication* on page 172).

Note: *To save power when your unit is running on batteries, you may wish to disable the Wi-Fi device when you do not use it.*

To connect to a wireless network:

1. From the right side of the screen, swipe left to display the Charm bar.
2. Tap **Settings**, and then the  icon.



3. Tap the item corresponding to the wireless network to which you want to connect.

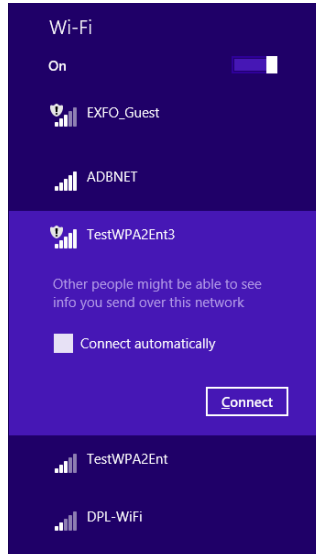

4. Tap **Connect**.
5. If the network is protected by a network security key (password) enter it in the corresponding box and tap **Next**.
6. Follow the on-screen instructions.

Note: *Since all networks are different, you may also need to configure other parameters before being able to transfer data via Wi-Fi. For information on the configuration specific to your network, contact your network administrator.*

As soon as the connection is established, you can start working with the selected wireless network. When you have finished, from the **Networks** list, tap **Disconnect** to stop communication with the wireless network.

Managing Data

Using the USB to RS-232 Adapter

Using the USB to RS-232 Adapter

If you want to transfer data between your unit and a device that is only equipped with RS-232 (serial) ports, you have to use a USB/RS-232 adapter (sold by EXFO).

Once the adapter has been detected, the unit assigns it a COM port number (for some adapters, values do not begin at COM 1). This COM port number is kept in memory even when you turn the unit off. This means that next time you connect the same adapter to any of the USB ports, the unit will recognize the adapter and identify it with the saved COM port number.

The communication between your unit and the device is established using the PuTTY application.

To use the USB/RS-232 adapter:

1. Turn on both the unit and the serial device.
2. Connect as shown. You can connect the USB end of the adapter to any of the USB ports.

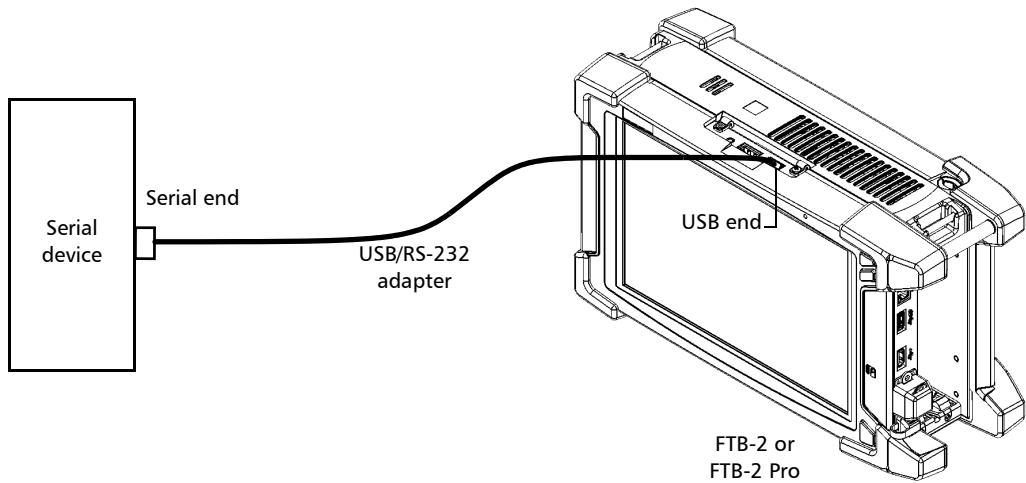

Note: *If the device that you want to use is a computer (not equipped with USB ports) you may want to use a null-modem serial cable as an “extension cable” between the device and the USB/RS-232 adapter.*

The adapter will be detected automatically on your unit.

Managing Data

Using the USB to RS-232 Adapter

3. From your unit, retrieve the COM port of the adapter as follows:

3a. From the main window, tap the **System Settings** button.

3b. Tap **Control Panel**.



3c. Tap **Hardware and Sound**.

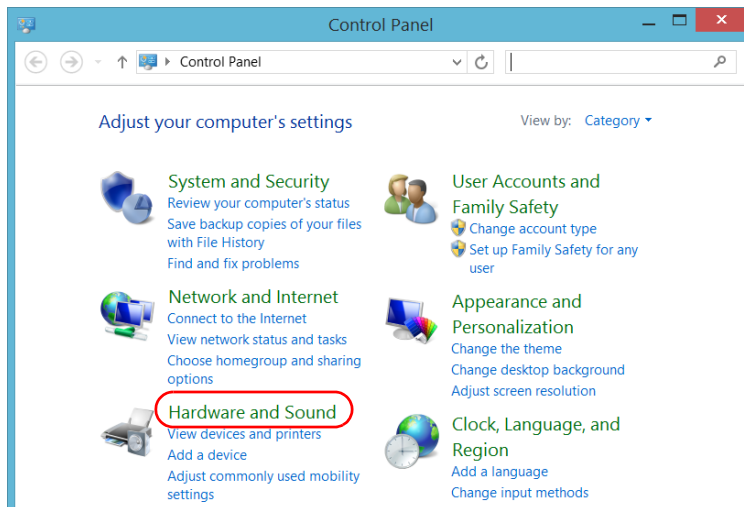

3d. Under **Devices and Printers**, tap **Device Manager**.

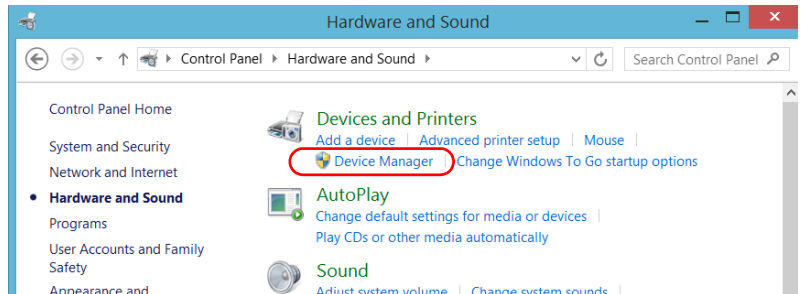

3e. Expand the **Ports (COM & LPT)** list to retrieve the COM port number that has been assigned to the adapter (identified as *USB Serial Port*) and write it down.

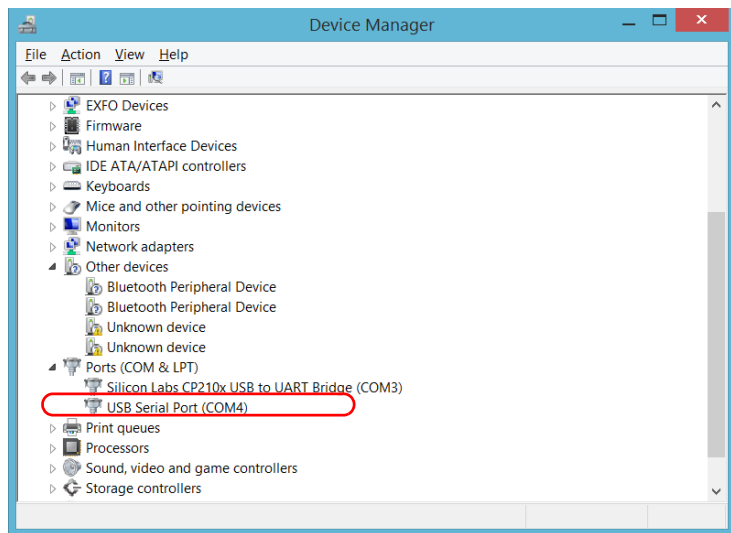

3f. Close the *Device Manager*.

Managing Data

Using the USB to RS-232 Adapter

4. From your unit, configure the communication parameters as follows:
 - 4a. From the main window, tap the **Utilities** button.
 - 4b. Tap **PuTTY**.
 - 4c. Configure the parameters.

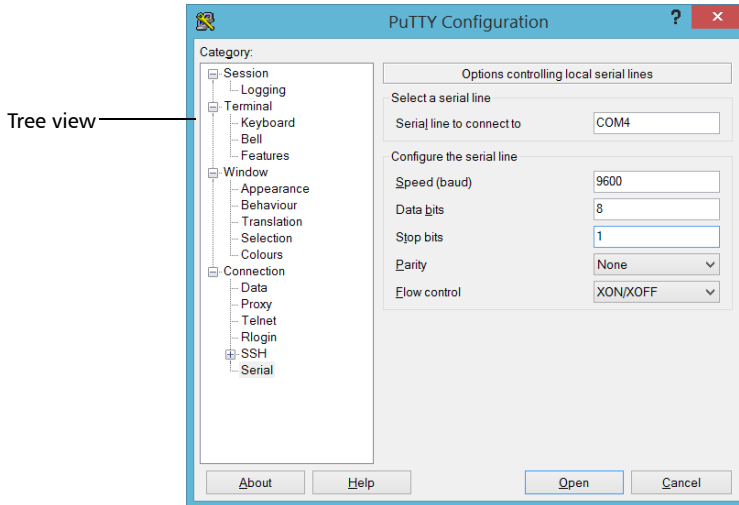

- From the tree view, select **Connection** > **Serial** and set the parameters as needed. Ensure that the COM port that you specify corresponds to the one that you wrote down at step 3e.
 - If you want to view the characters that you type on screen, from the tree view, select **Terminal**. Under **Local echo**, set the value to **Force on**.
 - From the tree view, select **Session**. Select **Serial**. The COM port number and the speed should correspond to those that you have previously entered.
- 4d. Tap **Open**. The unit is now ready to receive or send data.

5. From the device, set the communications parameters.



IMPORTANT

To be able to establish a communication between the unit and the device, you must set the following parameters to the same values as those defined on your unit:

- Speed
- Data bits
- Stop bit
- Parity
- Flow control

Note: *The COM port number that you set on your device will probably differ from the one that you used on your unit.*

6. From the device, establish communication with the unit using your favorite communication tool (PuTTY, HyperTerminal, etc.).

Freeing Up Disk Space with the Disk Cleanup Utility

If you need to free up disk space on your unit, you can use the Windows Disk Cleanup utility.

With this utility, you can clear files such as the Internet temporary files, files from the Recycle bin, or even files that you no longer need from the previous installation. The files from the previous installation are stored in the *Windows.old* folder that Windows creates automatically when you perform a refresh operation. To avoid losing data, you may want to back up files from this folder before removing it.

To free up disk space with the Disk Cleanup utility:

1. If desired, back up your data.

Note: *If you want to have a look at the content of the Windows.old folder containing files of the previous installation, go to the root of the C drive (Windows (C:)). If you do not see the Windows.old folder, it means no refresh operation has ever been performed on your unit.*

2. From the main window, tap the **System Settings** button.

3. Tap Control Panel.



4. Tap System and Security.

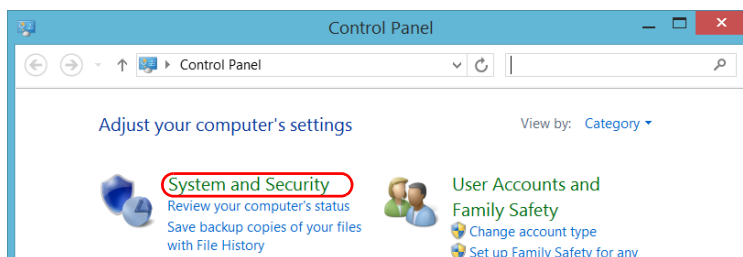

Managing Data

Freeing Up Disk Space with the Disk Cleanup Utility

5. Tap **Administrative Tools**, and then double-tap **Disk Cleanup**.

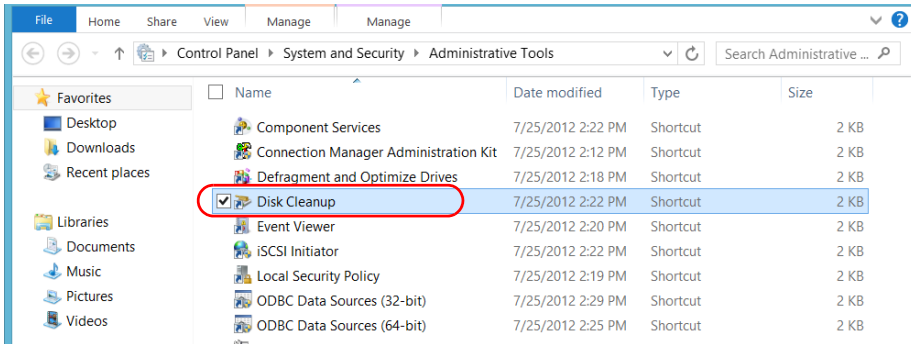

6. If you want to remove system files such as the files from the Windows.old folder, tap **Clean up system files**.

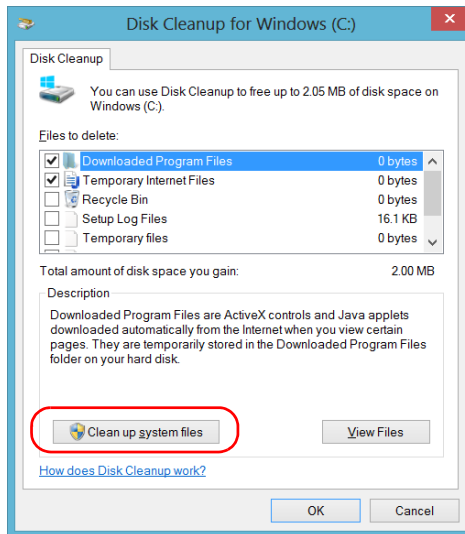

7. When the folders are displayed, select the check box corresponding to the desired item. If you want to clear the Windows.old folder, select the **Previous Windows installation(s)** check box. Ensure that all the other check boxes are cleared.

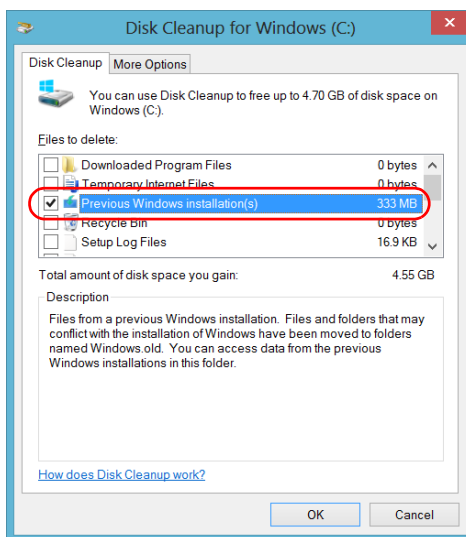

Note: *If you cannot see the **Previous Windows installation(s)** check box, this means that no refresh operation has been made on your unit yet.*

8. Tap **OK**.
9. When the application prompts you to confirm the deletion of the folder, tap **Delete Files**.

Managing Data

Enabling or Disabling the Wireless Communication

Enabling or Disabling the Wireless Communication

By default, the internal wireless module is enabled on your unit if you have purchased the Wi-Fi and Bluetooth option.

However, if you do not intend to work with a wireless network for a certain period of time, you may wish to disable the Wi-Fi device to extend battery life. If you prefer, you can disable both the Wi-Fi device and the 3G USB modem key at the same time by activating the “airplane mode”.



IMPORTANT

You cannot disable the Bluetooth device either manually or with the airplane mode.

When you activate the airplane mode, only the Wi-Fi device and the 3G USB modem key (connected to your unit) are disabled.

You can enable the Wi-Fi device and the 3G USB modem key again at any time.

To enable or disable the wireless communication on an FTB-2 Pro:

1. From the right side of the screen, swipe left to display the Charm bar.
2. Tap **Settings**, and then the  icon.
3. Set the wireless communication parameters as needed.
 - If you want to set the parameters for the Wi-Fi device and the 3G USB key at the same time, set the **Airplane mode** slider to the **Off** position to enable the communication, or to the **On** position to disable it.

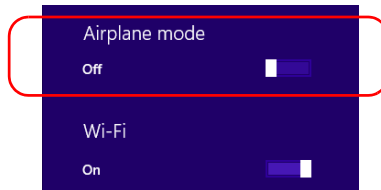

- On an FTB-2 Pro, if you want to set the parameters for the Wi-Fi device only, set the **Wi-Fi** slider to the **On** position to enable the communication, or to the **Off** position to disable it.

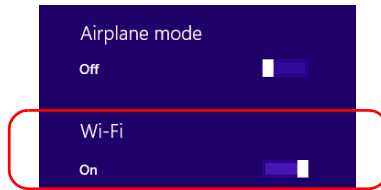

Managing Data

Enabling or Disabling the Wireless Communication

To enable or disable the wireless communication on an FTB-2:

- 1.** From the right side of the screen, swipe left to display the Charm bar.
- 2.** Tap **Settings**, and then **Change PC Settings**.
- 3.** Tap **Wireless**.

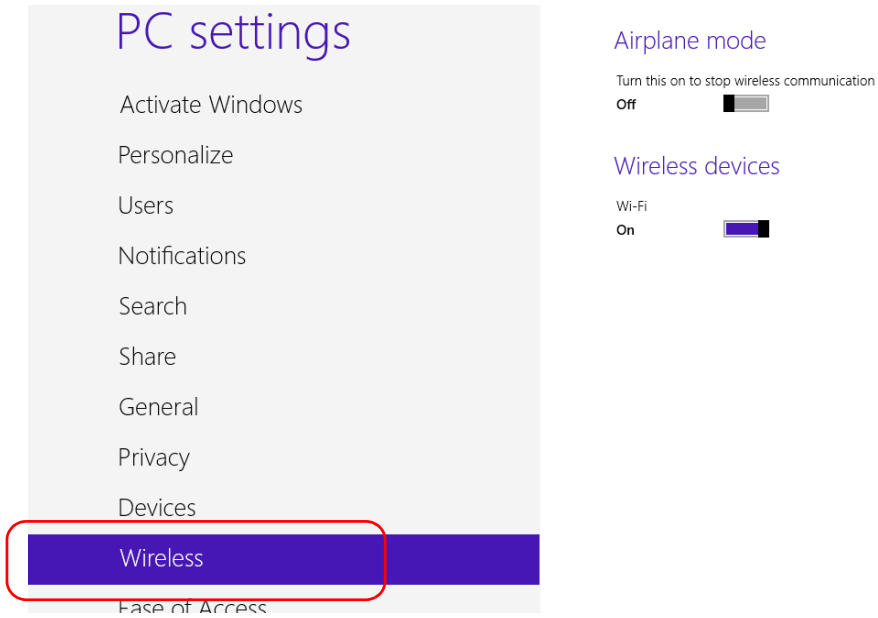

4. Set the wireless communication parameters as needed.
 - If you want to set the parameters for the Wi-Fi device and the 3G USB key at the same time, set the **Airplane mode** slider to the **Off** position to enable the communication, or to the **On** position to disable it.

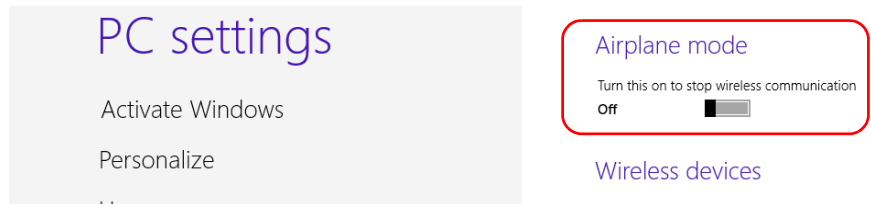

- If you want to set the parameters for the Wi-Fi device only, set the **Wi-Fi** slider to the **On** position to enable the communication, or to the **Off** position to disable it.

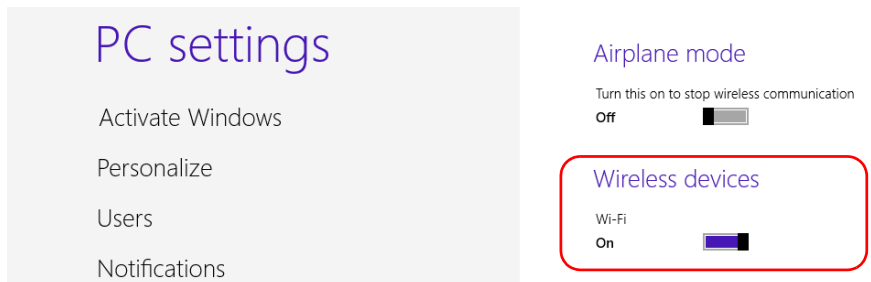

Connecting to a VPN from Your Unit

Note: *Only administrator-level users can install software under Windows. However, when the installation is complete, all users have the possibility to connect to the newly installed VPN from the unit.*

You can connect to a Virtual Private Network (VPN) from your unit if you use one of the VPN clients (applications) that are part of Windows 8.1 Pro or Windows Embedded 8 Standard, or provide your own compatible VPN client (FTB-2 Pro only). Such clients allow you to connect to the VPN of your company from anywhere in the world and have access to network resources as if your unit was connected locally to the network. This could be useful if you need to transfer data to a centralized folder on the company's private network, for example.

To establish the communication between the VPN client and the VPN server, you can use either a 3G USB modem key (see *Accessing the Internet with a 3G USB Modem Key* on page 133) or a standard Ethernet connection.

Note: *Since all networks are different, the parameters that you need to configure before being able to connect to the VPN may vary. For information on the configuration specific to your network, contact your network administrator.*



IMPORTANT

EXFO does not provide any VPN clients. You must either use one of the VPN clients available directly in Windows or provide the installation files for another VPN client yourself.

EXFO will not provide any support regarding the VPN clients or connection.



IMPORTANT

To avoid communication problems between the VPN client and the VPN server, ensure that the date set on your unit corresponds to the current date.

To add a VPN connection on an FTB-2 Pro:

1. From the right side of the screen, swipe left to display the Charm bar.
2. Tap **Settings** > **Change PC settings**.

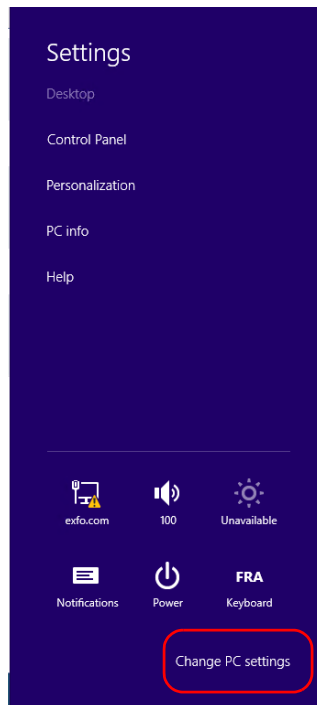

Managing Data

Connecting to a VPN from Your Unit

3. Tap Network.

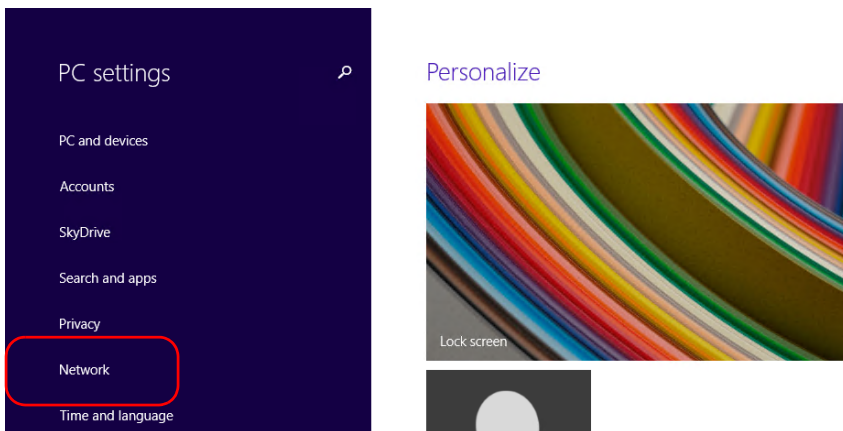

4. Tap Add a VPN connection and follow the on-screen instructions.

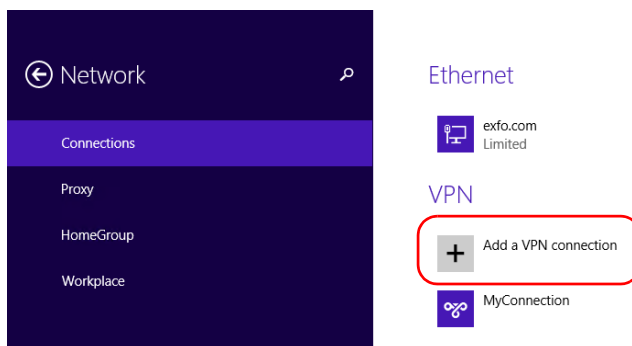

To add a VPN connection on an FTB-2:

1. From the main window, tap the **System Settings** button.
2. Tap **Control Panel**.

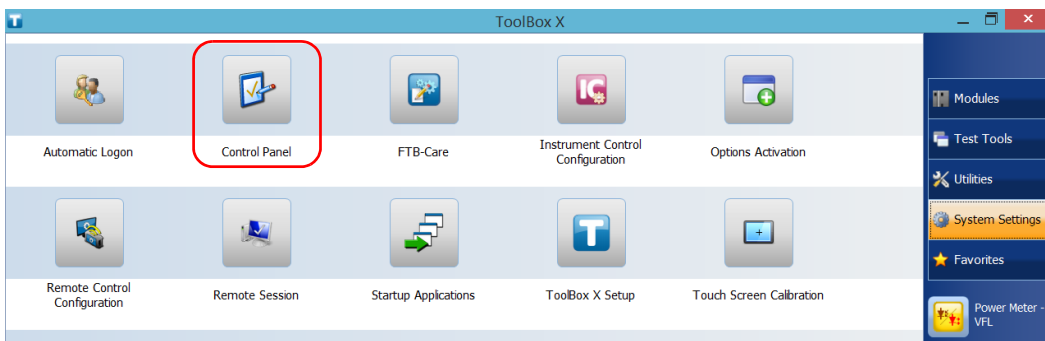

Managing Data

Connecting to a VPN from Your Unit

3. Tap **Network and Internet**.

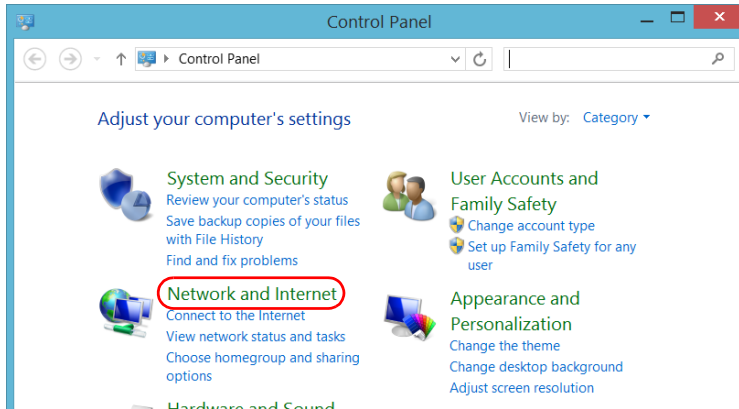

4. Under **Network and Sharing Center**, tap **View network status and tasks**.

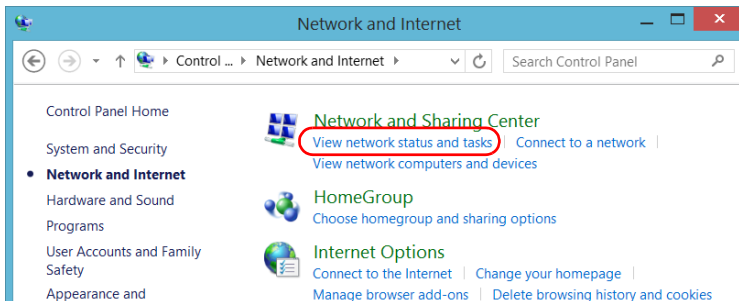

5. Tap **Set up a new connection or network**.

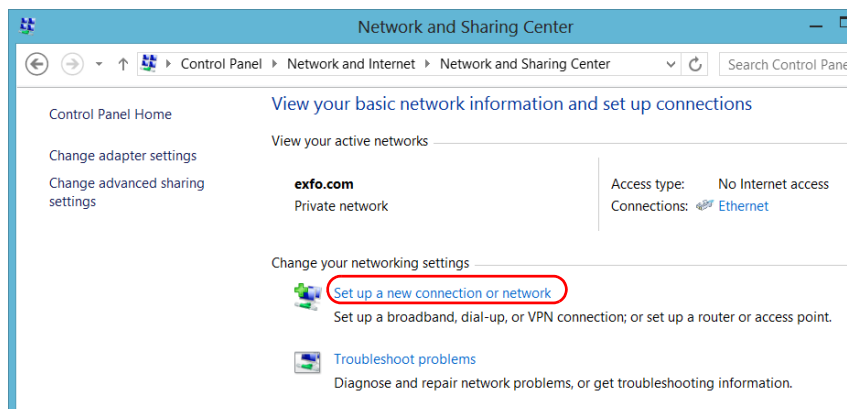

6. Tap **Connect to a workplace**, and then tap **Next**.

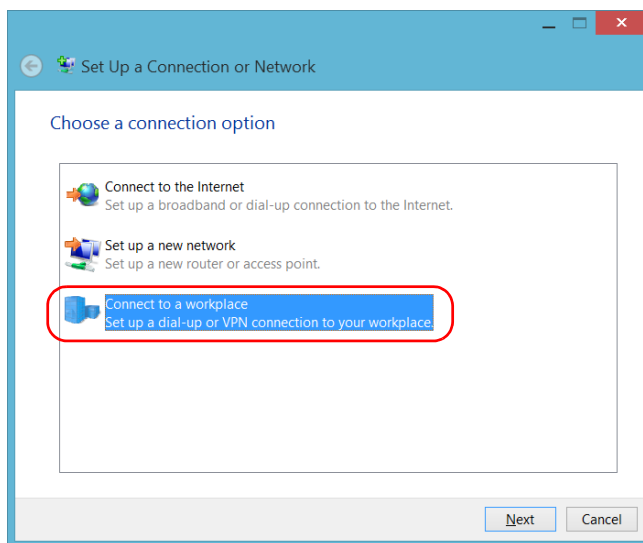

7. Follow the on-screen instructions.

Managing Data

Connecting to a VPN from Your Unit

To install a VPN client on your unit (FTB-2 Pro only):

1. If the date on your unit does not correspond to the current date, modify it (see *Adjusting the Date, Time and Time Zone* on page 111).
2. Start the installation of the VPN client using the files and settings provided by your network administrator.
3. Follow the on-screen instructions.

Once the installation is complete, all users will now be able to connect to a VPN from the unit.

To connect to a VPN from your unit:

1. From the main window, tap the **System Settings** button.
2. Tap **Control Panel**.



3. Tap Network and Internet.

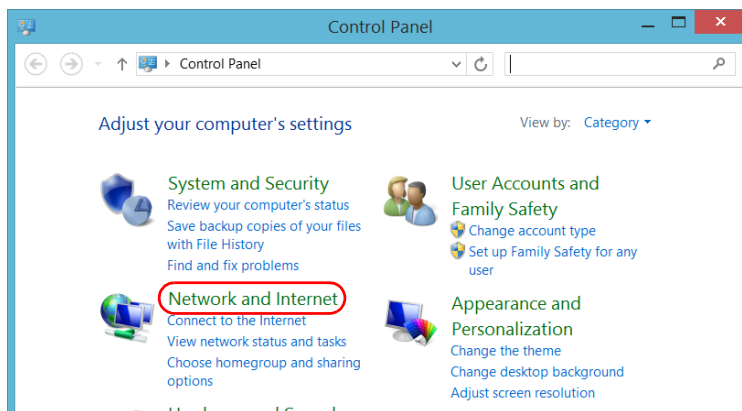

4. Under Network and Sharing Center, tap Connect to a network.

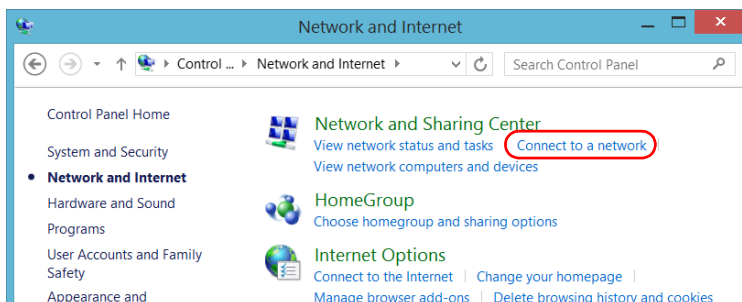

Managing Data

Connecting to a VPN from Your Unit

5. Under **Connections**, select the desired VPN connection.

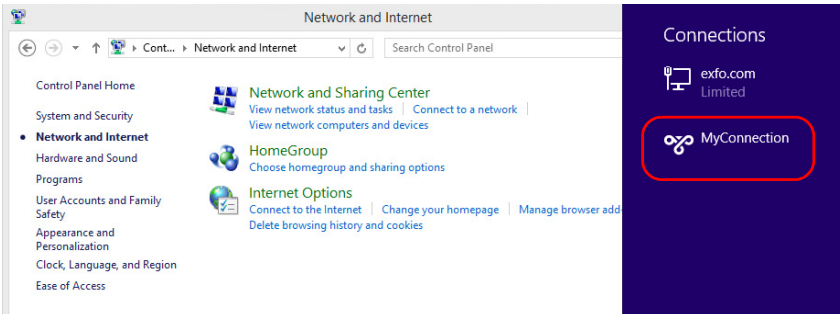

6. Follow the on-screen instructions.

If you are not sure about the information that you should provide, contact your network administrator.

9 Accessing Your Unit Remotely

You can access your unit remotely from a computer using either the Remote Desktop Connection or TightVNC Client applications.

This could be particularly useful if you do not intend to perform automation tasks on your platform. If you prefer to perform automation tasks on your platform and modules, see *Preparing for Automation* on page 213, *Using Your Unit and Modules in an Automated Test Environment* on page 251, or *Preparing to Control Modules with a Dedicated Application* on page 246

The table below presents the differences between the two applications.

Characteristic	Remote Desktop Connection	TightVNC Client
Type of connection	Direct between the unit and the computer; only one user can be connected to the unit at a time. Usually, the connection is made with the user name of the person currently logged on the unit. Otherwise, this person will be automatically disconnected.	Not exclusive; several users can be connected to the unit at the same time (sharing the same session).
Windows user rights	Taken into account.	Not taken into account.
Password-protected	Yes; mandatory. The user name and password are the same as those used to connect to the unit. By default, all the accounts with administrator rights can use Remote Desktop Connection. If you want accounts with limited rights to be able to use Remote Desktop as well, you must specifically grant them access.	Yes; mandatory. The password is defined on the TightVNC Server, the first time you start the server. This password is not related to the one used to connect to the unit. By default, all people that use TightVNC Client will enter the same password (as defined on the server). Each user to whom you provide the password will be able to connect to the unit via TightVNC.

Working with Remote Desktop

By default, the remote access to your unit with Remote Desktop is not enabled. However, once you enable it, all the accounts with administrator rights can use Remote Desktop. If you want accounts with limited rights to be able to use it as well, you must specifically grant them access.

You can also configure the unit to prevent users from accessing it remotely.

Accessing Your Unit with Remote Desktop

To be able to connect to the unit using Remote Desktop, you must:

- Allow the remote access to your unit (only necessary the first time that you access your unit with Remote Desktop).
- Know the IP address of the unit and provide it in the connection settings on the computer.

Note: *If your unit and the computer are on the same network, you can even use the computer name of your unit, followed by its serial number. You can view the computer name of your unit from **System Settings > Remote Session > Computer Name**.*

- Use an account that is secured by a password. Remote Desktop will not allow any connection with empty passwords.
- Enter the appropriate user name when Remote Desktop application prompts you. Usually, this user name must correspond to the user name of the person currently logged on the unit. Otherwise, you will disconnect the person that was already connected.

To allow the remote access to your unit with Remote Desktop:

1. From the main window, tap the **System Settings** button.
2. Tap **Remote Session**.



3. Under **Remote Desktop**, select **Allow remote connections to this computer**.

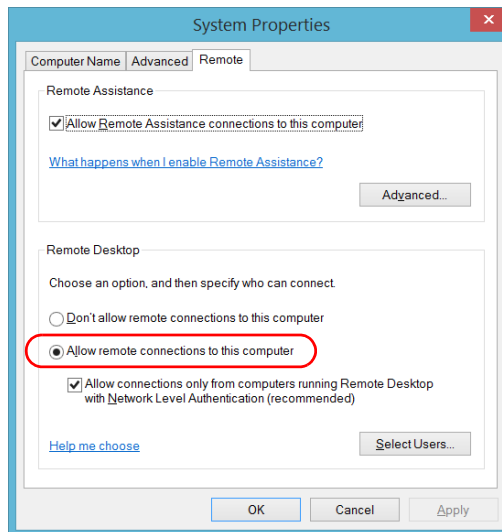

4. Tap **OK** to confirm the changes and return to the **System Settings** window.

Accessing Your Unit Remotely

Working with Remote Desktop

To access your unit remotely with Remote Desktop:

1. Connect both the computer and your unit to the same network and make sure they can “see” each other as network restrictions might prevent them from communicating.
 - If you want to use an Ethernet network, connect an RJ-45 (network) cable to the unit’s Ethernet (RJ-45) port located on its right panel.
 - If you want to use a wireless network, see *Connecting to a Wireless Network* on page 160.
 - You could also create a Private Area Network with your Bluetooth device (contact your network administrator).
2. Turn on both the computer and the unit.
3. On your unit, from Toolbox X, tap the  button (located at the bottom of the button bar).

4. Select the **Platform** tab, write down the IP address, and then close the window.

Note: *It may take a few seconds before you see the IP address on the list.*

5. From the computer, open the Remote Desktop Connection window.
 - If your computer runs Windows Vista or Windows 7: On the taskbar, click **Start**, then select **All Programs > Accessories > Remote Desktop Connection**.
 - If your computer runs Windows 8: On the taskbar, point the lower left corner, and then click the **Start** screen icon. Right-click the bottom of the screen, and then click **All apps**. Under **Windows Accessories**, select **Remote Desktop Connection**.
 - If your computer runs Windows 8.1: On the taskbar, click the **Start** button (), then under **Windows Accessories**, select **Remote Desktop Connection**.
6. In the **Connecting to Remote Desktop** window, in the **Computer** list, type the IP address of the unit that you wrote down at step 4.

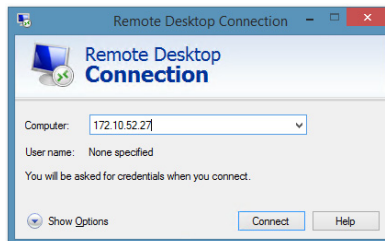

7. Click **Connect**.
8. When the application prompts you, enter your user name and password.
9. Click **OK** to open the session.

Accessing Your Unit Remotely

Working with Remote Desktop

Allowing Users with Limited Accounts to Use Remote Desktop

By default, only the accounts with administrator rights can use Remote Desktop. However, you can assign extra user rights to accounts with limited rights so that they can also use Remote Desktop.

To allow a user with limited accounts to use Remote Desktop:

1. From the main window, tap the **System Settings** button.
2. Tap **Remote Session**.



3. Under **Remote Desktop**, select **Allow remote connections to this computer**.

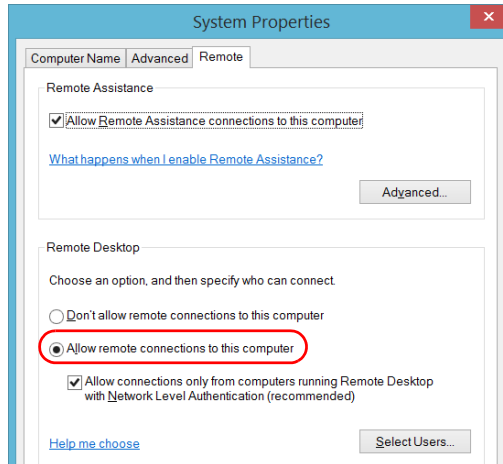

4. Tap **Select Users**.

5. From the **Remote Desktop Users** dialog box, tap **Add**.

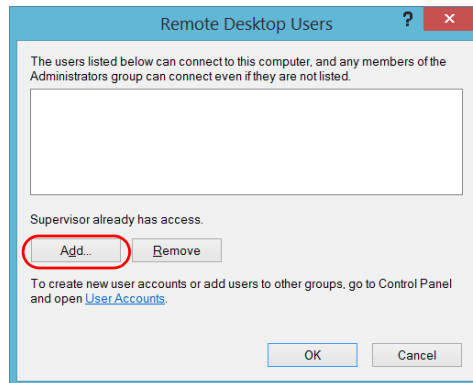

Accessing Your Unit Remotely

Working with Remote Desktop

- From the **Select Users** dialog box, tap **Advanced**.

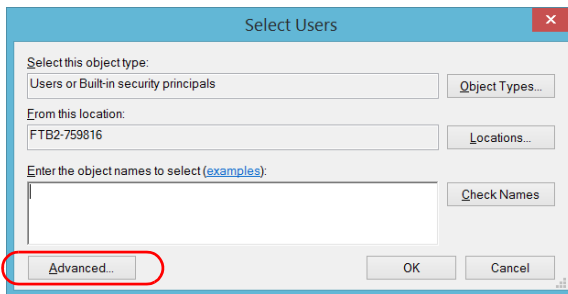

- Tap **Find Now** to let the system find and display the list of users.

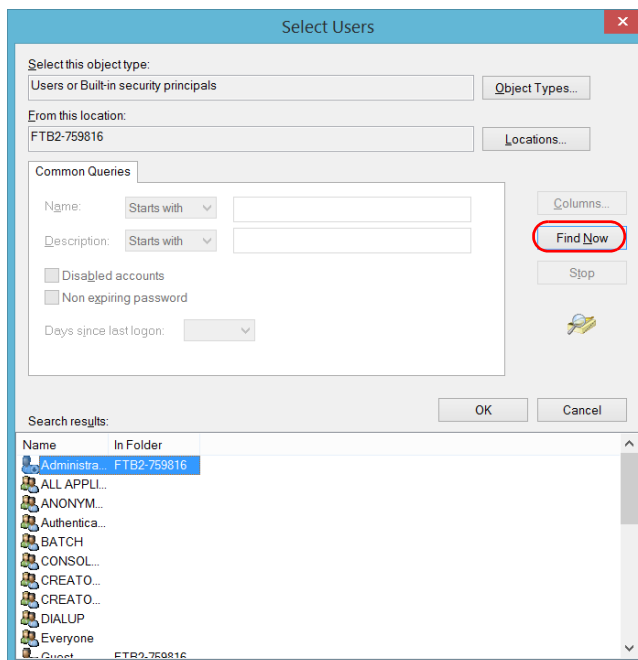

- Select the user to which you want to grant access rights, and then tap **OK**.

9. From the list of users, select the user that you have just added, and then tap **OK**.

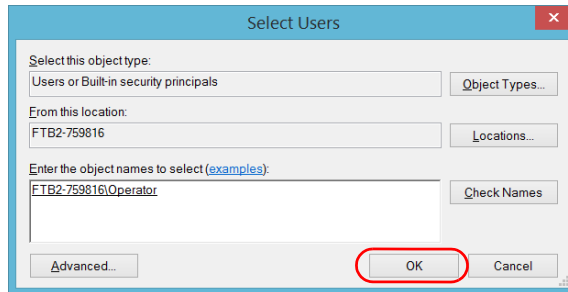

10. Repeat steps 7 to 9 with all the users to which you want to grant access rights.
11. From the **Remote Desktop Users** dialog box, tap **OK**.
12. From the **System Properties** dialog box, tap **OK** to confirm the changes and return to the **System Settings** window.

Accessing Your Unit Remotely

Working with Remote Desktop

Preventing Users from Connecting with Remote Desktop

You can also configure the unit to prevent users to access it using Remote Desktop. However, all users having administrator user rights will be able to modify this setting at any time.

To prevent users from connecting to the unit using Remote Desktop:

1. From the main window, tap the **System Settings** button.
2. Tap **Remote Session**.



3. Under **Remote Desktop**, select **Don't allow remote connections to this computer**.

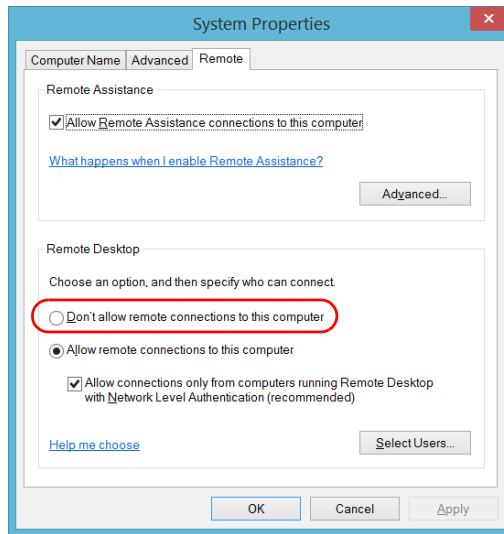

4. Tap **OK** to confirm the changes and return to the **System Settings** window.

Working With TightVNC

The control of your unit with TightVNC requires the TightVNC Server (already installed on your unit) and the TightVNC Client Viewer (that you must install on your computer).

By default, the remote access to your unit with TightVNC is not enabled. Once you enable it, you may want to define a connection password for increased security. This is not mandatory; you can also configure the VNC Server to allow connections without authentication.

To be able to connect to the unit using TightVNC, you must:

- Know the IP address of the unit and provide it in the connection settings on the computer.
- Know the password (same for all users by default).

This section provides you with the basic information to control your unit with TightVNC.

Configuring the TightVNC Server

The TightVNC Server is already installed on your unit. By default, the server is configured to accept secured connections only. This means that you must configure a password before establishing a connection between a computer and your unit.

However, you can modify the desired type of connection if you prefer not to be prompted for a password. You can also modify other connection settings to better suit your needs.

To configure the TightVNC Server:

1. From the notification area, tap the TightVNC icon.



2. Select the **Server** tab.
3. Under **Incoming Viewer Connections**, select **Accept incoming connections**.

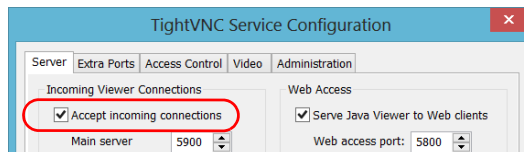

Accessing Your Unit Remotely

Working With TightVNC

4. If you want to secure the connection with a password, select the **Require VNC authentication** check box. If you prefer not to be prompted for a password when you connect with TightVNC, clear the check box.

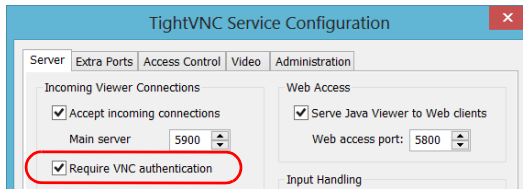

5. If you prefer a connection secured with a password, proceed as follows:
 - 5a. Depending on the type of connection that you want, under **Primary password** or **View-only password**, tap the corresponding **Set** button.

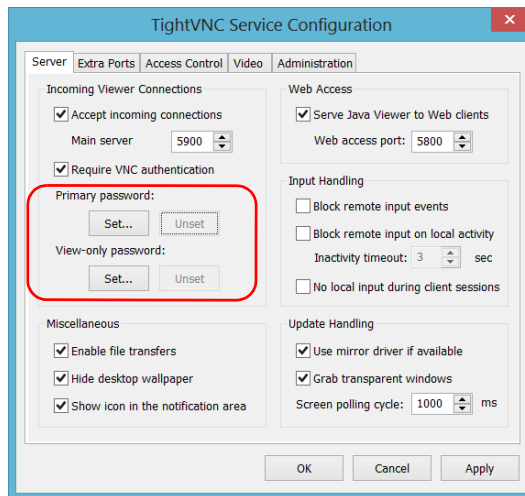

- 5b.** Type the desired password, and confirm it.

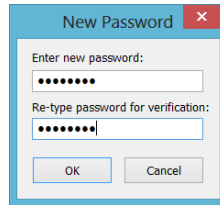

- 5c.** Tap **OK** to keep the new password.

Note: *The primary and view-only passwords are independent of each other. They do not have to be identical.*

- 6.** Tap **Apply**, and then **OK**.

Installing the TightVNC Viewer on a Client Computer

If the TightVNC Viewer is not already installed on your computer, you can download it from the Web for free.



IMPORTANT

EXFO does not provide licenses for TightVNC Viewer. Always ensure that you are entitled to install it on your computer.

To install the TightVNC Viewer on your computer:

- 1.** Open a Web browser and go to <http://www.tightvnc.com/>.
- 2.** Download the version of the viewer that corresponds to the operating system that your computer is running.
- 3.** Double-click the file that you have just downloaded to start the installation.
- 4.** Follow the on-screen instructions.

Connecting to Your Unit with TightVNC

Once the TightVNC Viewer is installed on your computer, you are ready to access your unit remotely.

To connect to your unit with TightVNC:

1. Connect both the computer and your unit to the same network and make sure they can “see” each other as network restrictions might prevent them from communicating.
 - If you want to use an Ethernet network, connect an RJ-45 (network) cable to the unit’s RJ-45 port located on its right panel.
 - If you want to use a wireless network, see *Connecting to a Wireless Network* on page 160.
 - You can also create a Private Area Network with your Bluetooth device (see *Transferring Data via Bluetooth* on page 151).
2. Turn on both the computer and the unit.
3. On your unit, ensure that ToolBox X is open.
4. At the bottom of the button bar, tap .

5. Tap **Platform**.
6. Scroll down until you can see the IP address.

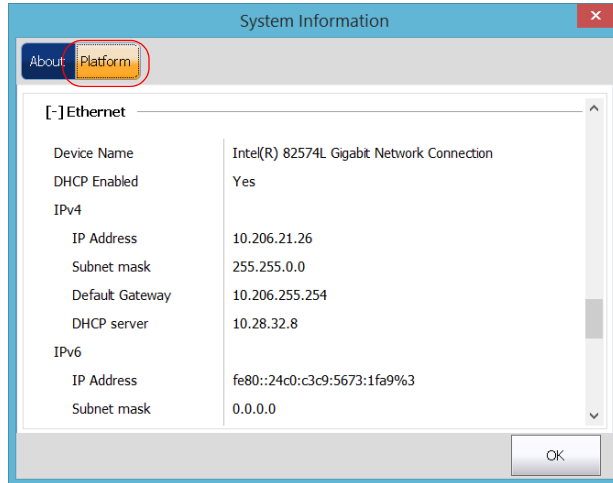

7. Write down the IP address, and then close the window.

Note: *It may take a few seconds before you see the IP address on the list.*

8. From your computer, start the TightVNC Viewer.

Accessing Your Unit Remotely

Working With TightVNC

9. In the **Remote Host** list, type the IP address of your unit that you wrote down at step 7.

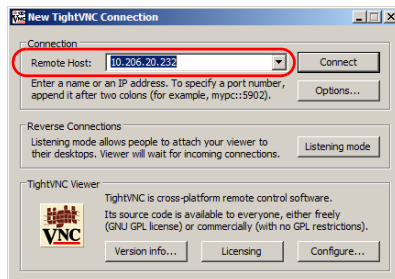

Note: *The appearance of the TightVNC Viewer window may vary depending on the version of the viewer that you have.*

10. Click **Connect**.
11. If the application prompts you for a password, enter it and click **OK** to confirm.

Adding Exceptions to the Firewall

Note: Only administrator-level users can add exceptions to the firewall.

Your unit is protected by the Microsoft firewall to prevent unauthorized access when it is connected to a network or to the Internet. The firewall has been preconfigured so that all the applications that come with your unit work properly. However, you can allow other applications to access the network or the Internet by adding exceptions.

If you are not sure about how to configure the firewall, contact your network administrator.

To add exceptions to the firewall:

1. From the main window, tap the **System Settings** button.
2. Tap **Control Panel**.



Accessing Your Unit Remotely

Adding Exceptions to the Firewall

3. Tap **System and Security**.

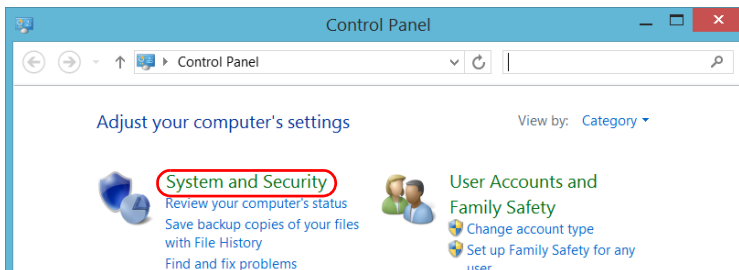

4. Under **Windows Firewall**, tap **Allow an app through Windows Firewall**.

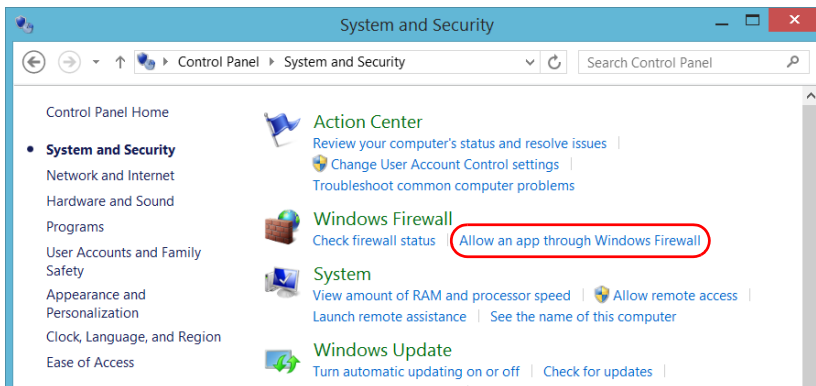

5. Tap the **Change settings** button.

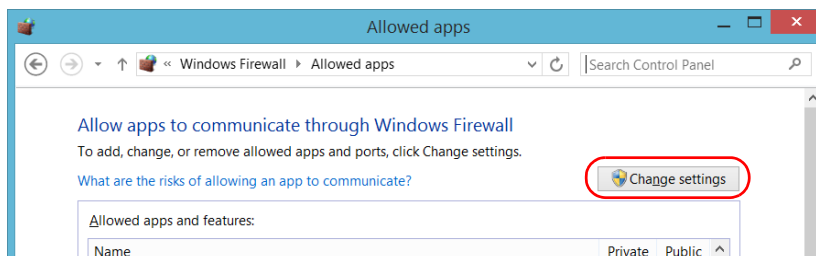

6. Tap the **Allow another app button.**

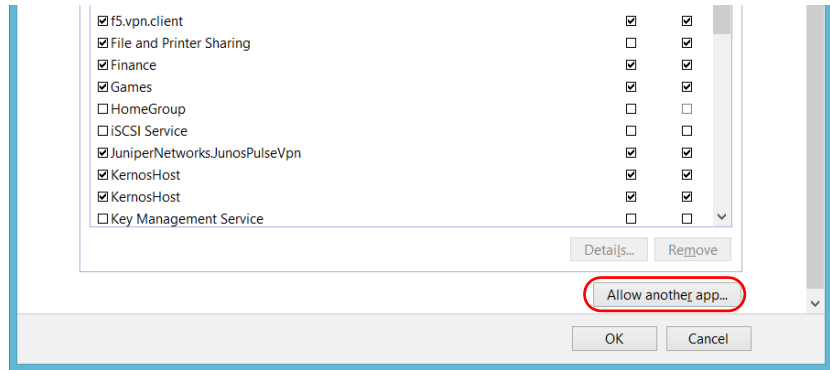

7. Select the desired application from the list, and then tap **Add.**

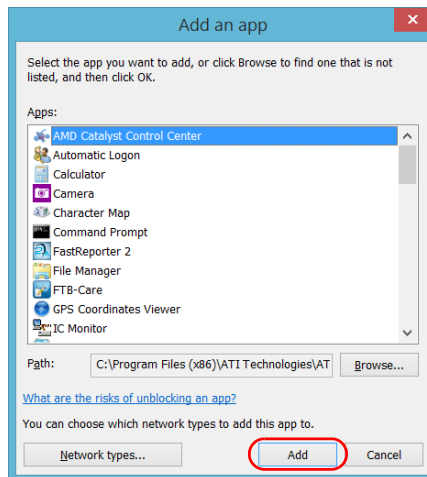

Accessing Your Unit Remotely

Adding Exceptions to the Firewall

8. Ensure that the **Private** and **Public** settings of the added application suit your needs.

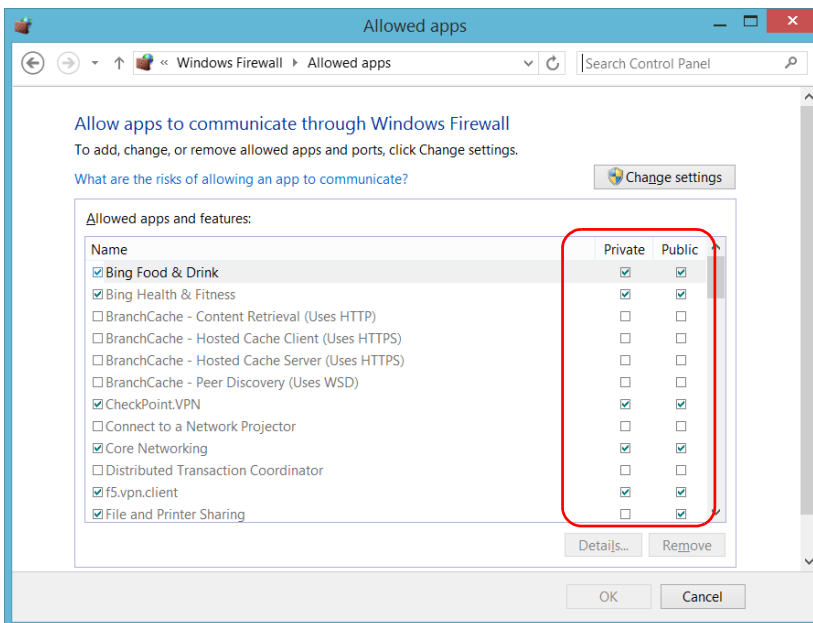

9. When you have finished, tap **OK** to confirm the changes and return to the **Control Panel** window.

10 Testing Network Connections

Note: This function is available with the optional IPT software package only.

The two most common basic tests widely used in networking are the *ping* test and the *trace route* test. With these tests, you can ensure that IP packets travel as expected from a local host to a remote host and vice versa.



IMPORTANT

To avoid misleading results, always ensure that your unit is only connected to one network at a time (either standard Ethernet or wireless network) before performing ping or trace route tests.

Performing a Ping Test

The ping test is a basic test that measures the average time it takes for a packet to reach the remote host. With this test, you can quickly verify that the remote host functions properly.

The ping test has six common parameters:

- The URL (IP address)
- The number of packets to send
- The packet size
- The maximum time allowed for a packet to reach the remote host
- The maximum number of hops allowed for reaching the remote host (TTL)
- A flag to indicate whether a packet can be fragmented.

When the test is complete, you can export the results. You can later import the generated text file (tab-delimited) directly into Microsoft Excel.

Testing Network Connections

Performing a Ping Test

To perform a ping test:

1. From the main window, tap **Test Tools**.
2. Tap **IP Tools**.

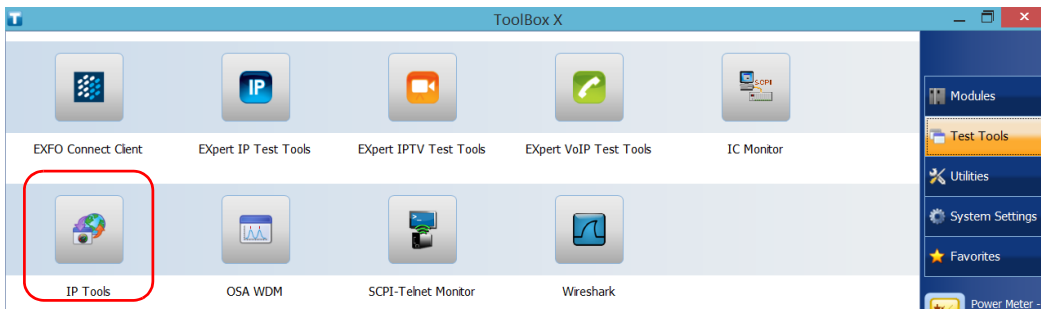

3. From **IP Testing Tools**, select the **Ping** tab.

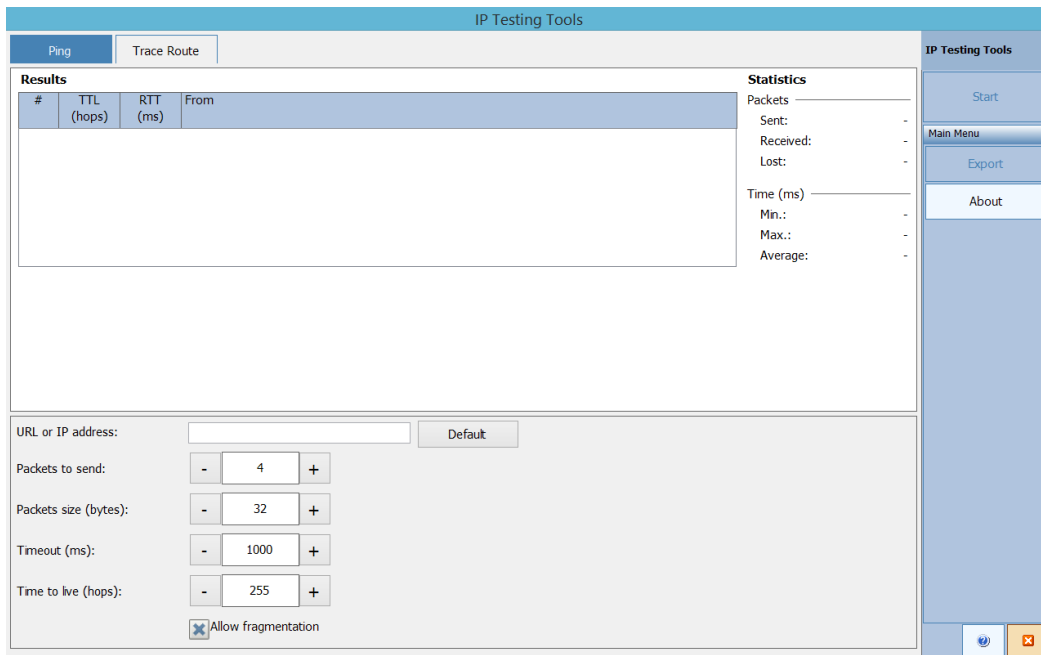

4. Enter a URL or an IP address to reach. You can tap the **Default** button to use the unit's default ping address. The default value cannot be configured.
5. Set the other parameters:
 - Number of packets to send
 - Packet size
 - Timeout limit
 - TTL limit
 - Clear the **Allow fragmentation** check box if you prefer sending complete packets to the host.
6. Tap the **Start** button.

You can stop a ping test at any time by tapping the **Stop** button.

Performing a Trace Route Test

The trace route test is used to evaluate the average number of nodes that are required to reach the final host. It is often used to troubleshoot networks (identify accesses blocked by firewalls or routing problems).

This trace route test utility enables you to:

- Enter a remote host address.
- Set the maximum time allowed for a packet to reach the remote host.
- Set the maximum number of hops allowed for reaching the remote host (TTL).
- Choose whether to resolve DNS for the IP address or not.

When the test is complete, you can export the results. You can later import the generated text file (tab-delimited) directly into Microsoft Excel.

To perform a trace route test:

1. From **IP Testing Tools**, select the **Trace Route** tab.
2. Enter an URL or an IP address to reach. You can tap the **Default** button to use the unit's default trace route address. The default value cannot be configured.

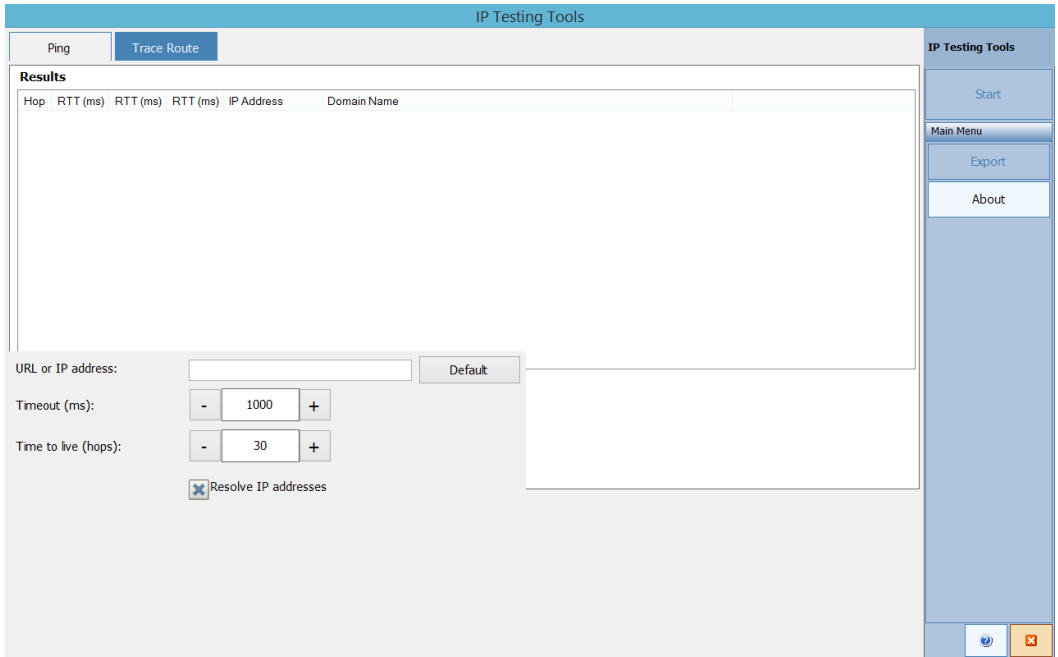

3. Set the other parameters:
 - Timeout limit
 - TTL limit
 - Select or clear the **Resolve IP addresses** check box if you want to get the host name for the corresponding IP address of nodes.
4. Tap the **Start** button.

You can stop a trace route test at any time by tapping the **Stop** button.

Exporting the Results

When a test is complete, you can export the results of the current test page. If you want to keep your results for future use, you must export them because result files cannot be opened directly from your unit.

Results are sent to a text file. Fields are separated by the “TAB” character to simplify the importation into a Microsoft Excel worksheet.

By default, the application suggests a file name:

- For ping tests:

Ping for [URL] on [YEAR]_[MONTH]_[DAY].txt

- For trace route tests:

Trace Route for [URL] on [YEAR]_[MONTH]_[DAY].txt

Where:

- [URL] is the entered URL or IP address,
- [YEAR] is the year of the test,
- [MONTH] is the month of the test,
- [DAY] is the day of the test.

Example:

For a ping test at www.yoursite.org made on July 3rd, 2014, the suggested filename would be:

Ping for www.yoursite.org on 2014_07_03.txt

To export results:

Tap the **Export** button. If necessary, modify the suggested file name.

11 Preparing for Automation

Your unit was designed to meet the requirements of automation and to facilitate its integration with your test environment.

Note: *To have access to automation features on an FTB-2 unit, you must purchase the Automation option.*

EXFO supplies commands that follow the guidelines determined by the SCPI consortium for many instruments. EXFO also supplies COM properties and events allowing you to build your own application. The instruments can be controlled either locally or remotely via the following technologies:

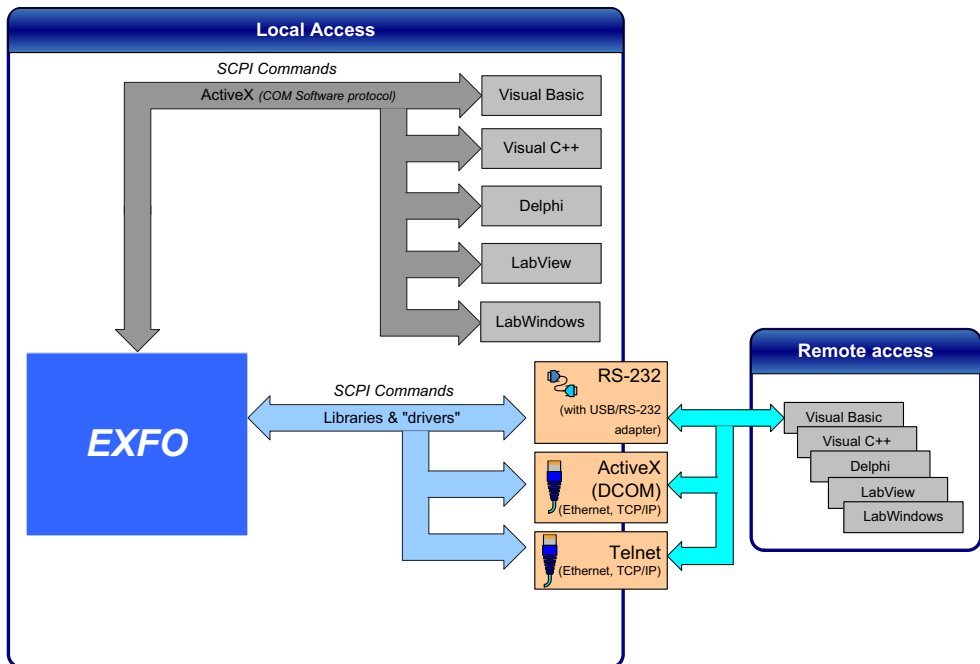

Preparing for Automation

The choice of a technology depends on your particular needs.

Control	Technology	Characteristics
Local	ActiveX (COM)	<ul style="list-style-type: none"> ➤ Allows you to develop an application that will run locally on your unit within Windows ➤ Best approach when speed is your top priority (no physical connection that slows down the process) ➤ Supported by most development software ➤ Lower cost
Remote	ActiveX (DCOM) (Ethernet, TCP/IP)	<ul style="list-style-type: none"> ➤ Allows the sharing of network resources ➤ Allows you to develop computer-based applications to directly communicate with your unit
Remote	RS-232	<ul style="list-style-type: none"> ➤ USB to RS-232 adapter (purchased from EXFO) required to establish connection between the computer and your unit. ➤ For increased speed and performance, run the application locally on your unit through ActiveX instead of using RS-232
Remote	Telnet (Ethernet, TCP/IP)	<ul style="list-style-type: none"> ➤ Your unit can be directly connected to a Local Area Network (LAN) or Wide Area Network (WAN) via its 10/100/1000 Base-T interface ➤ Allows the sharing of network resources ➤ Allows you to develop computer-based applications very easily to directly communicate with your unit

For more information on programming aspects, see the section on using your product in an automated test environment.

Linking Units with the Ethernet Port

Your unit is equipped with an Ethernet port (10/100/1000) to send and receive data. Refer to the Windows documentation for information about Ethernet port settings and possibilities.

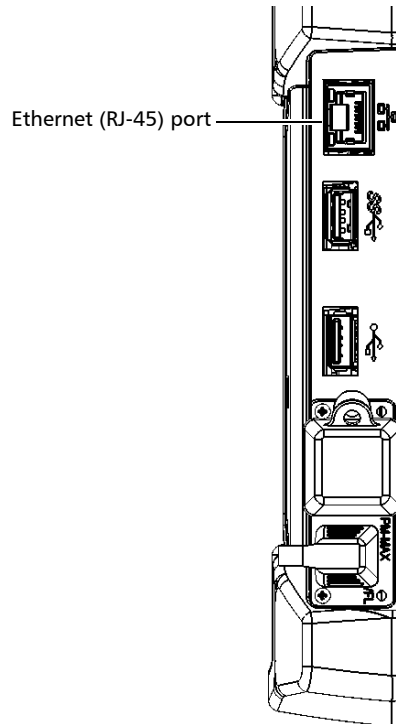

Linking Units Using a Serial Port

Your unit is not equipped with a serial (RS-232) port, but you can connect a USB to RS-232 adapter (sold by EXFO) to your one of the USB ports of your unit if you wish to send and receive data via RS-232.

Getting Optimum Performance from Your Unit

Several factors influence the data transfer rate of your unit. The information presented hereafter will help you get the best transfer rate possible.

- *Output unit (RS-232, ActiveX and TCP/IP):* Your unit can return results in
 - linear units (for example, watts)
 - log units (for example, dBm)

Since internal units are linear, you will get optimal performance by using linear units for output (no need for an internal conversion to log).

Note: *You must make the choice of output unit for each instrument offering such a feature. Refer to the user guide of each optical instrument for a list of available commands and queries.*

- *Output format (RS-232, ActiveX and TCP/IP):* Your unit provides the following output formats for measurement results:
 - ASCii
 - PACKed

Generally, the PACKed format allows to pass three to four times more information than the ASCii format for the same transfer rate. Often, the PACKed format is also more efficient since it reduces your unit's CPU work load (no need for an internal conversion to ASCII format).

Note: *The PACKed format will only be applied to <DEFINITE LENGTH ARBITRARY BLOCK RESPONSE DATA> and <INDEFINITE LENGTH ARBITRARY BLOCK RESPONSE DATA>.*

Note: *The choice of data format cannot be made directly via the ToolBox X software.*

For more information on how to set the output format and data types, see *:FORMat[:DATA](IEEE 488.2 and specific commands appendix)*, *Read* and *ReadBinary* (COM properties and events appendix), and the data types appendix.

Changing Communication Settings

Communication settings cannot be modified without turning on your unit and starting ToolBox X.

To change communication settings:

1. Tap the **System Settings** button, then tap **Instrument Control Configuration**.

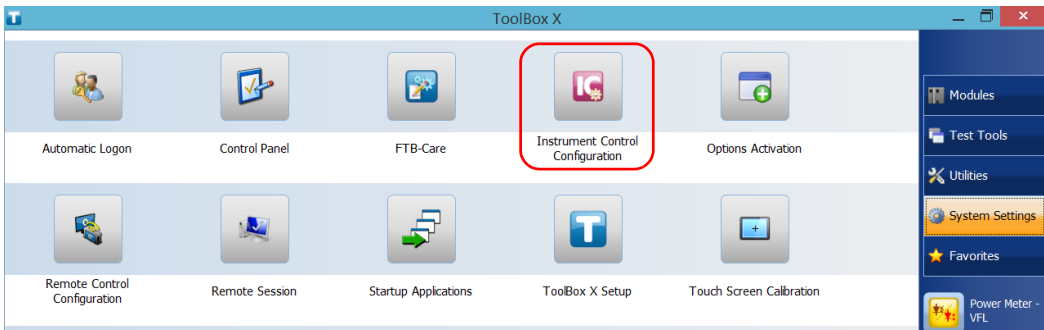

2. Tap **Change settings**, and then, when the application prompts you to authorize the changes to your unit (identified as “computer”), tap **Yes**.

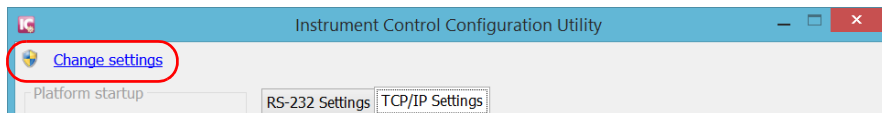

- Under **Platform Startup**, determine whether your module applications will be started locally or remotely by clicking the corresponding option.
 - If **Local** mode is selected, you will not be able to send remote commands to your unit.
 - If **Remote** mode is selected, all modules in your unit will be initialized upon startup so you are ready to send remote commands.

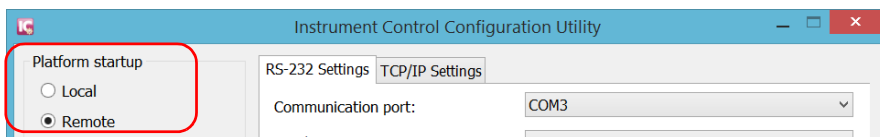

If you selected **Local** mode, you can go directly to step 6.

- Under **Communication Type**, select **ActiveX**, **RS-232**, or **TCP/IP**

For more information on the choice of a particular type, see the table on page 214.

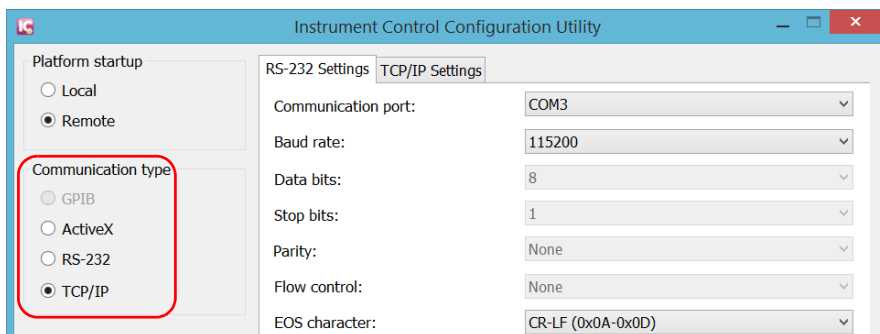

Note: *If the selected communication type does not match the protocol that will actually be used, an error message is displayed when attempting to control the instruments.*

Preparing for Automation

Changing Communication Settings

5. According to the communication type you have selected, customize the corresponding parameters as shown below.

➤ For RS-232

Serial port—used to connect the RS-232 cable.

Determines the speed at which data is sent between the unit and a computer, in bits per second (b/s).

End-of-string (EOS) character—used to indicate the end of a data string (when sending or receiving data).

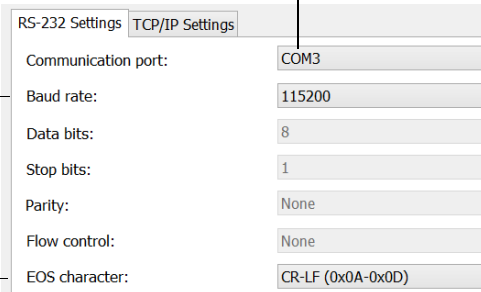

RS-232 Settings	TCP/IP Settings
Communication port:	COM3
Baud rate:	115200
Data bits:	8
Stop bits:	1
Parity:	None
Flow control:	None
EOS character:	CR-LF (0x0A-0x0D)

➤ For TCP/IP

TCP/IP port 5024—used to connect over Telnet.



RS-232 Settings	TCP/IP Settings
Port:	SCPI-Telnet (Port 5024)

For information on communicating with TCP/IP over Telnet, see the section pertaining to communication through TCP/IP over Telnet.

6. Tap **Apply** to confirm your changes.

To revert to default general settings:

1. Tap the **Restore Default Settings** button.

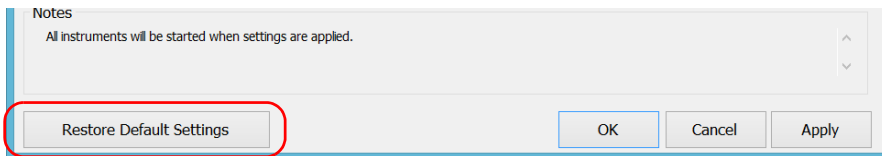

2. Tap **Apply** to confirm your changes.

To revert to default RS-232 settings:

1. Tap the **Default RS-232 Settings** button.

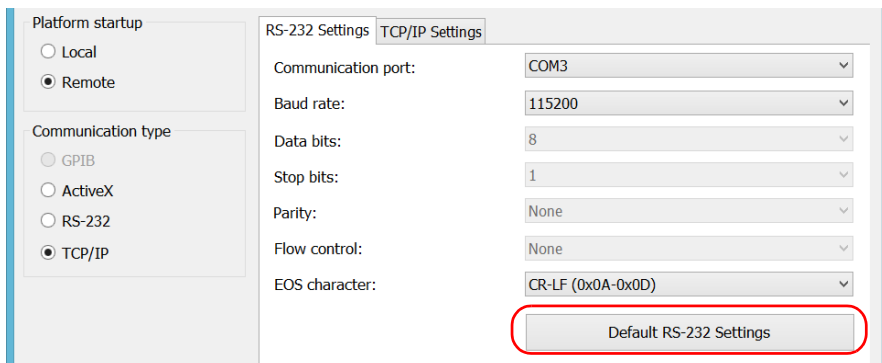

2. Tap **Apply** to confirm your changes.

Configuring DCOM Access to Your Unit

DCOM technology allows to control devices and optical instruments via Ethernet. The EXFO IcSCPIAccess Class component provided with your unit acts as a communication link between a client application and EXFO's Instrument Control.

DCOM ensures communication between the client application and Instrument Control via your local network. Since each network has its own configuration, you need to be familiar with network security, users, groups, domain management, etc. Basic programming skills are also required to work with DCOM. For more information, you can refer to the Microsoft MSDN Help feature, which provides exhaustive technical documentation on all DCOM issues.

The example presented in the following pages illustrates how to make the EXFO IcSCPIAccess Class component available to all users of a local network under Windows 8.1 Pro. The example provided below is for guidance only; it may not work properly with all networks and interfaces may slightly differ depending on the operating system used.

To enable DCOM access to your unit, you must:

- set the general security parameters
- customize the specific security parameters
- register callback events.

Setting the General Security Parameters

Note: *To modify the security parameters, you need administrator access rights.*

To set the general security parameters:

1. From the main window, tap the **System Settings** button.
2. Tap **Control Panel**.
3. Tap **System and Security > Administrative Tools**.
4. Double-tap **Component Services**.
5. In the **Component Services** dialog box, go to **Console Root > Component Services > Computers**.

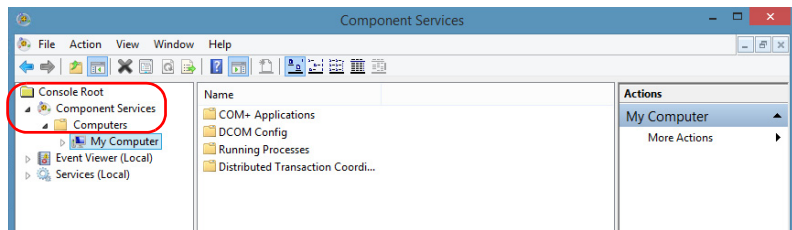

6. Right-click **My Computer**, and then select **Properties**.

Preparing for Automation

Configuring DCOM Access to Your Unit

7. In the **My Computer Properties** dialog box, tap the **COM Security** tab.
8. Under **Access Permissions**, tap **Edit Limits**.

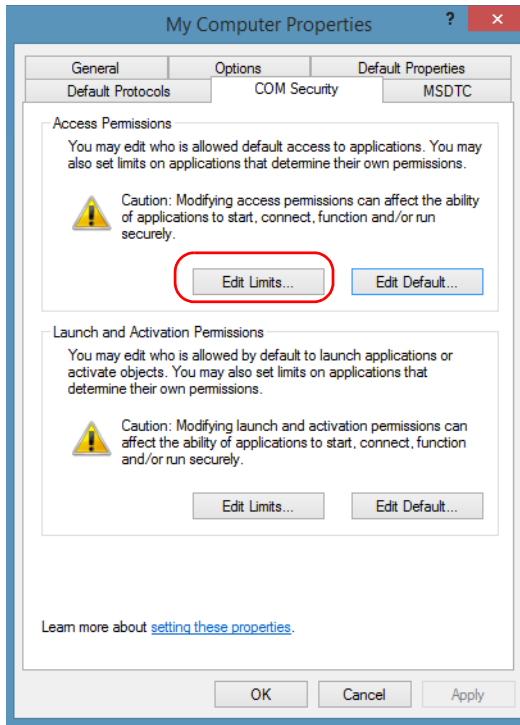

9. In the **Access Permission** dialog box, ensure that the **Distributed COM Users** appears in the **Group or user names** list.

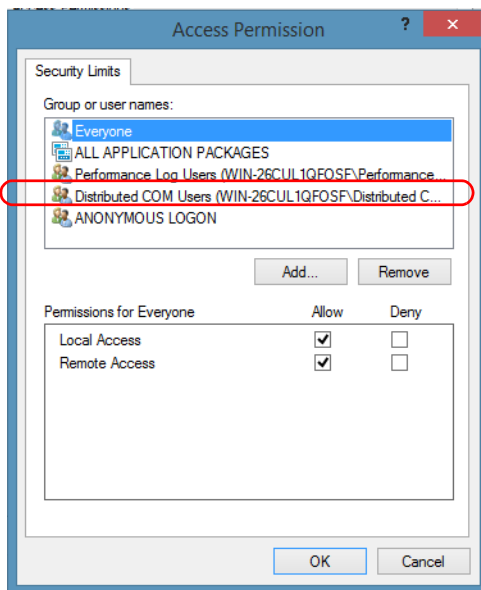

10. Tap **OK**.

11. In the **My Computer Properties** dialog box, tap the **COM Security** tab.

Preparing for Automation

Configuring DCOM Access to Your Unit

12. Under **Launch and Activation Permissions**, tap **Edit Limits**.

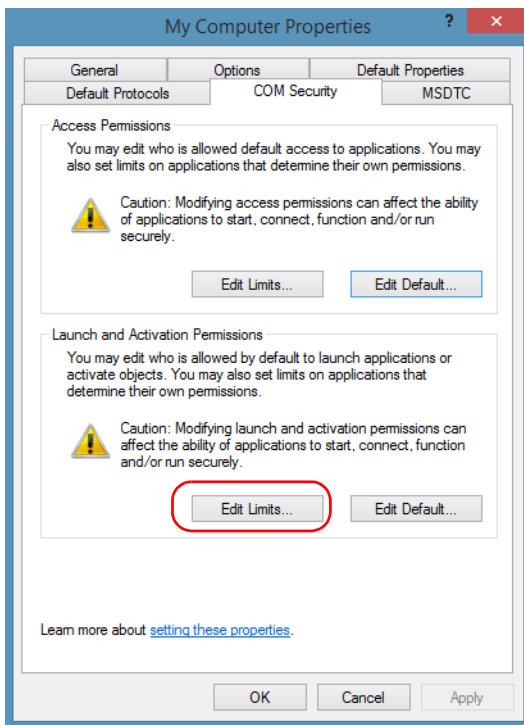

- 13.** In the **Access Permission** dialog box, ensure that the **Distributed COM Users** appears in the **Group or user names** list.

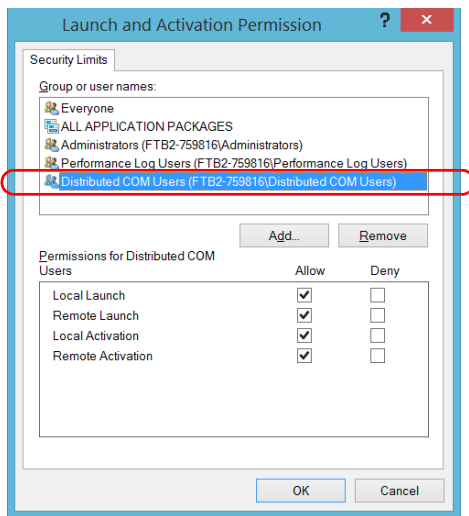

You can now allow users to access general DCOM services on your unit. You can either:

- Add a user to the **Distributed COM Users** group (refer to Microsoft help).
- OR
- Add a user explicitly and define both, access and launch permissions (see procedure below).

Note: *If you add a user explicitly, ensure to give remote access rights to the new user.*

Preparing for Automation

Configuring DCOM Access to Your Unit

To add a user explicitly:

- 1.** In the **My Computer Properties** dialog box, tap the **COM Security** tab.
- 2.** Under **Access Permission**, tap **Edit Limits**.
- 3.** In the **Access Permission** dialog box, tap **Add**.

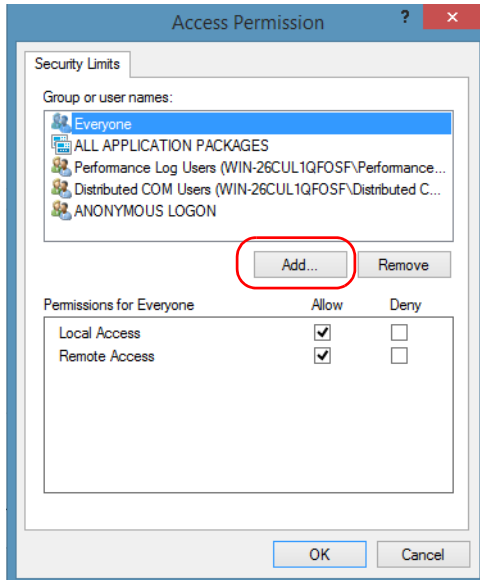

4. In the **Select Users or Groups** dialog box, under **Enter the object names to select**, type the name of the user to whom you want to give access rights.

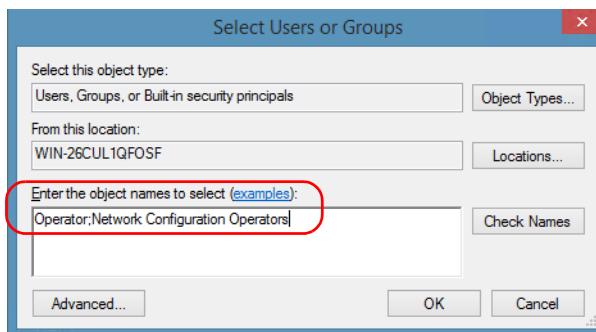

5. Tap **OK**.

Preparing for Automation

Configuring DCOM Access to Your Unit

6. Confirm the newly added user has remote access permission as follows:
 - 6a. In the **Access Permission** dialog box, select the name of the new user.

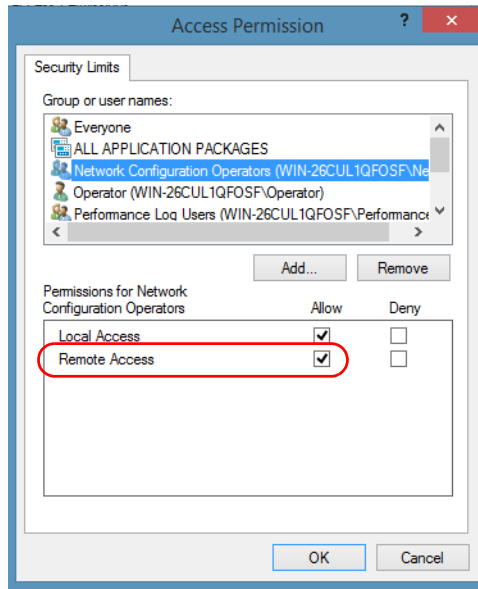

- 6b. Under **Permissions for** (new user), ensure **Allow** is selected for **Remote Access**.
 - 6c. Tap **OK**.
7. In the **My Computer Properties** dialog box, tap the **COM Security** tab.
8. Under **Launch and Activation Permissions**, tap **Edit Limits**.

- 9.** In the **Launch and Activation Permission** dialog box, tap **Add**.

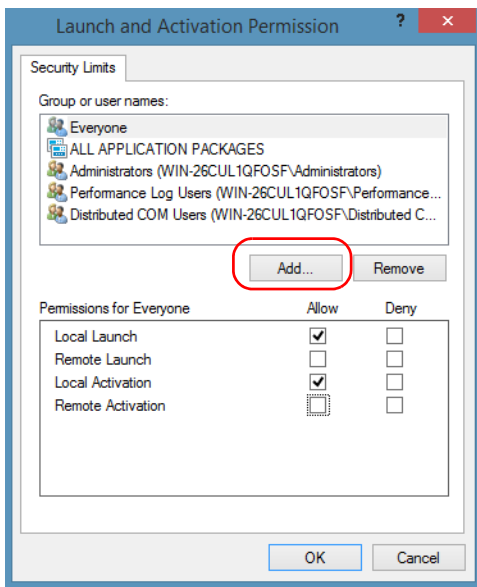

- 10.** In the **Select Users or Groups** dialog box, under **Enter the object names to select**, type the name of the user to whom you want to give start and activation access rights.

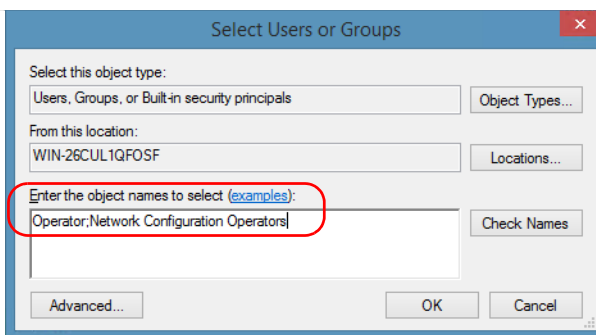

- 11.** Tap **OK**.

Preparing for Automation

Configuring DCOM Access to Your Unit

12. Confirm the newly added user has **Remote Launch** and **Remote Activation** permissions as follows:

12a. In the **Launch Permission** dialog box, select the name of the new user.

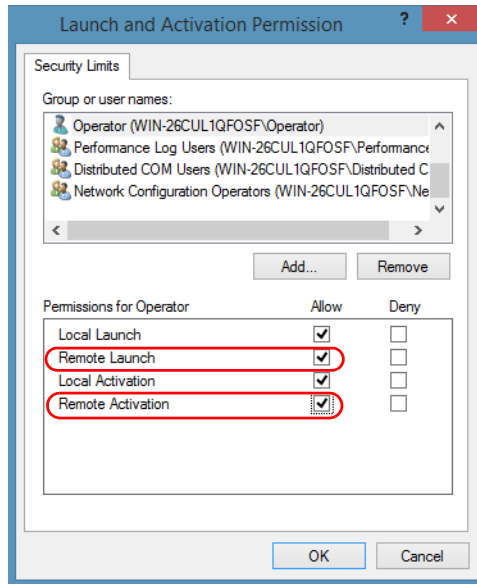

12b. Under **Permissions for** (new user), ensure **Allow** is selected for both **Remote Launch** and **Remote Activation**.

12c. Tap **OK**.

Customizing the Specific Security Parameters

Once you have defined the general security parameters, you can define the specific security parameters.

To customize the specific security parameters:

1. From the **Component Services** window, select: **Console Root > Component Services > Computers > My Computer > DCOM Config** to show the contents of the **DCOM Config** folder.

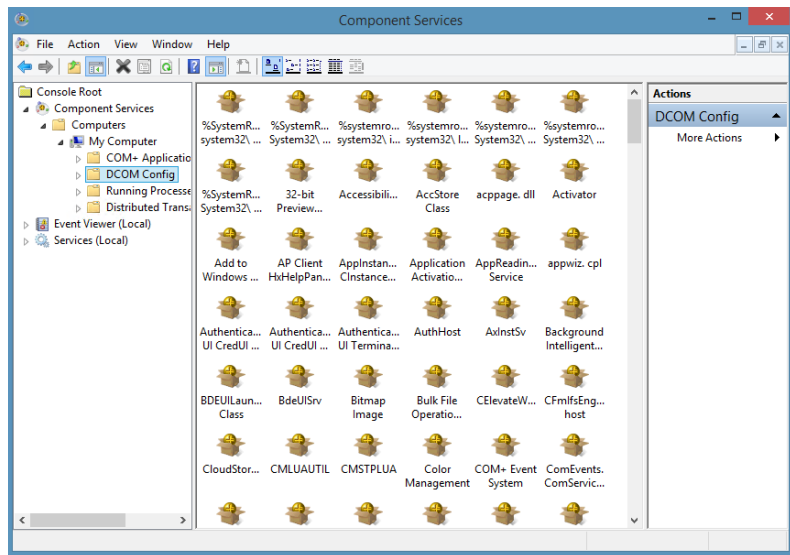

2. From **DCOM Config**, right-click **EXFO KernosHost**, and select **Properties**.
3. Tap the **General** tab.

Preparing for Automation

Configuring DCOM Access to Your Unit

4. In the **Authentication Level** list, select **Default**.

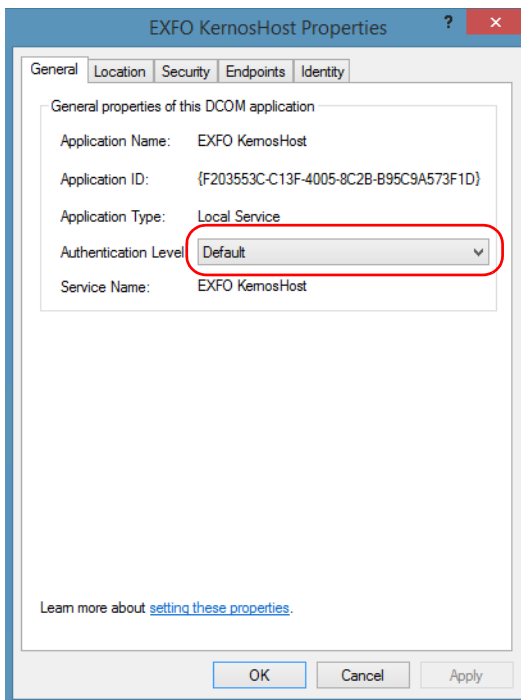

5. In the **EXFO KernosHost Properties** dialog box, tap the **Security** tab.
6. Under **Launch and Activation Permissions**, select **Customize**, and then click **Edit** to edit the list of allowed users.

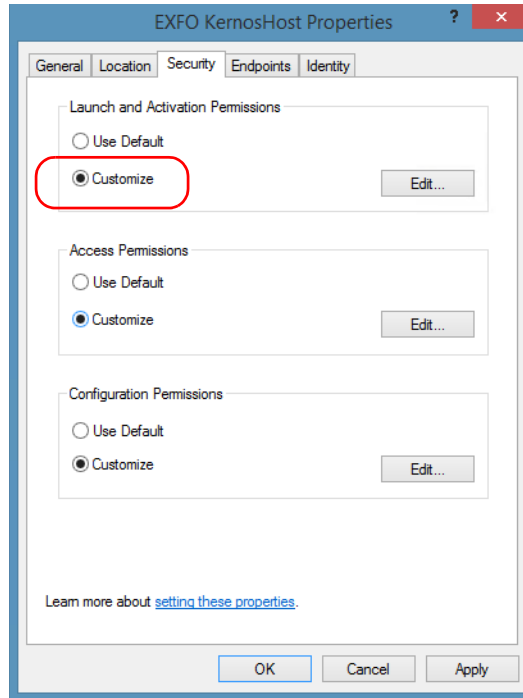

IMPORTANT

Customizing access rights sets both remote AND local permissions. As a result, you will have to specify every user who must have local access to the system (see *Setting the General Security Parameters* on page 223).

If you do not specify local access rights, no user will be able to access EXFO KernosHost and, therefore, no user will be able to start ToolBox X.

Preparing for Automation

Configuring DCOM Access to Your Unit

7. In the **Launch and Activation Permission** dialog box, tap **Add**.

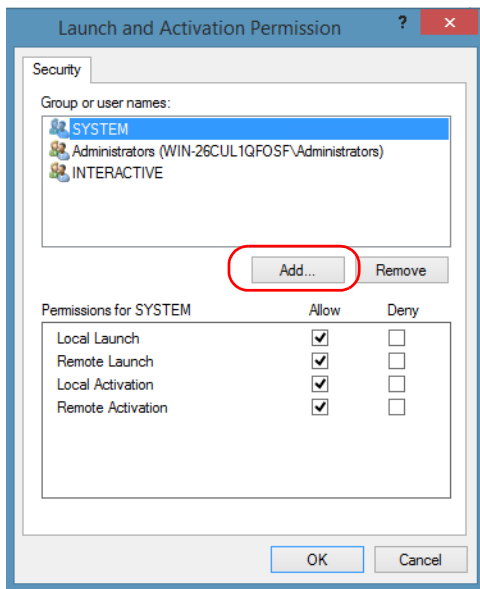

8. In the **Select Users or Groups** dialog box, under **Enter the object names to select**, type the name of the user to whom you want to give start and activation permissions for remote access.

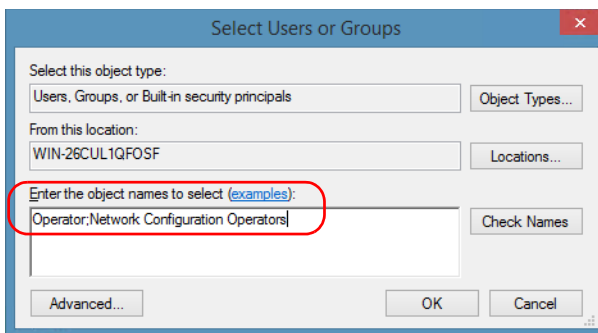

9. Tap **OK**.

- 10.** In the **Launch and Activation Permission** dialog box, select a user.
- 11.** To allow this user to start and activate the unit remotely, select **Allow** for all four permission choices.

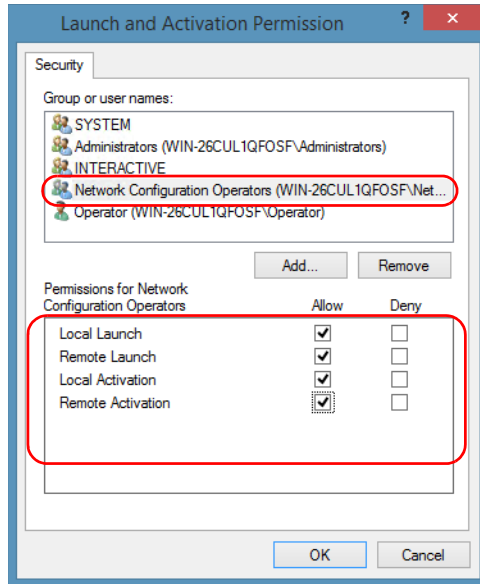

- 12.** Repeat steps 10 and 11 for each newly added user.
- 13.** Tap **OK**.

Preparing for Automation

Configuring DCOM Access to Your Unit

14. In the **EXFO KernosHost Properties** dialog box, tap the **Security** tab.
15. Under **Access Permissions**, select **Customize**, and tap **Edit** to edit the list of allowed users.

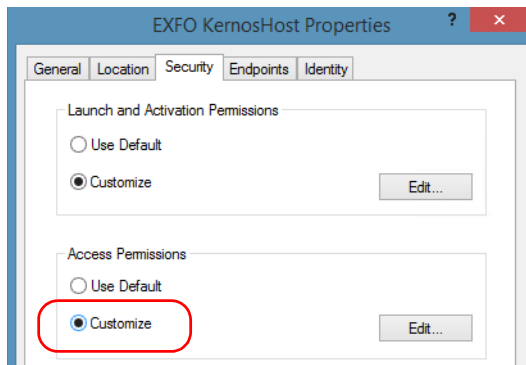

IMPORTANT

Customizing access rights sets both remote AND local permissions. As a result, you will have to specify every user who must have local access to the system (see *Setting the General Security Parameters* on page 223).

If you do not specify local access rights, no user will be able to access EXFO KernosHost and, therefore, no user will be able to start ToolBox X.

16. In the **Access Permission** dialog box, tap **Add**.

- 17.** In the **Select Users or Groups** dialog box, under **Enter the object names to select**, type the name of the user to whom you want to give access permissions for remote access.

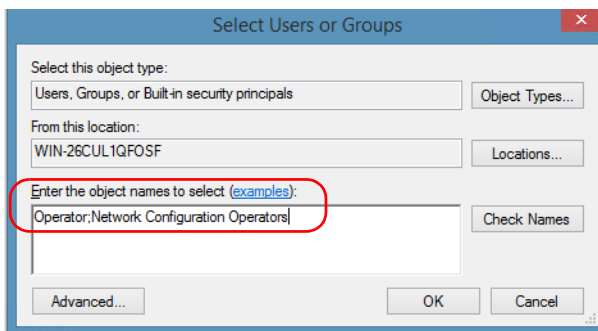

- 18.** Tap **OK**.

- 19.** In the **Access Permission** dialog box, select a user.

Preparing for Automation

Configuring DCOM Access to Your Unit

- 20.** To allow this user to access the unit remotely, select **Allow** for both permission choices.

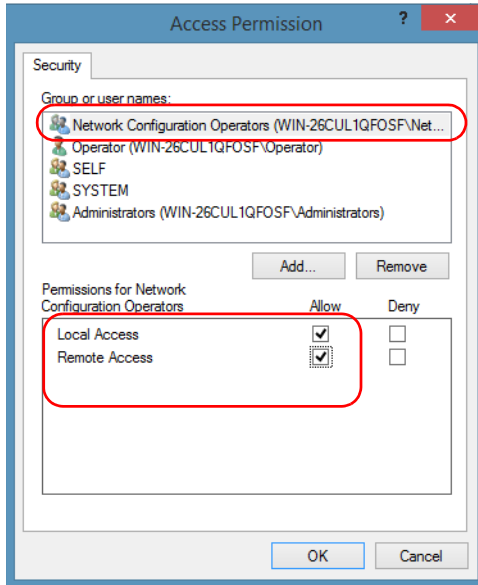

Note: You can also deny connection permission for specific users.

- 21.** Repeat steps 19 and 20 for each newly added user.
- 22.** Tap **OK** to close the **Access Permission** dialog box.
- 23.** Tap **OK** to close the **EXFO KernosHost Properties** dialog box.
- 24.** Restart your unit.

The EXFO ICSPIAccess Class component, located on your unit, can now be accessed with DCOM.

Enabling DCOM on Client Computer

Note: To run *DCOMCNFG.EXE*, you need Administrator access rights.

If you want to subscribe to EXFO IcSCPIAccess Class component events, you need to set security parameters on the client computer.

To enable DCOM on the client computer:

1. Start Windows, on the taskbar, click **Start** (Start button () under Windows 8.1) and select **Run**.
2. In the **Open** box, type “DCOMCNFG.EXE” and tap **OK**.
3. In the **Component Services** dialog box, select: **Console Root > Component Services > Computers** to show available computers.

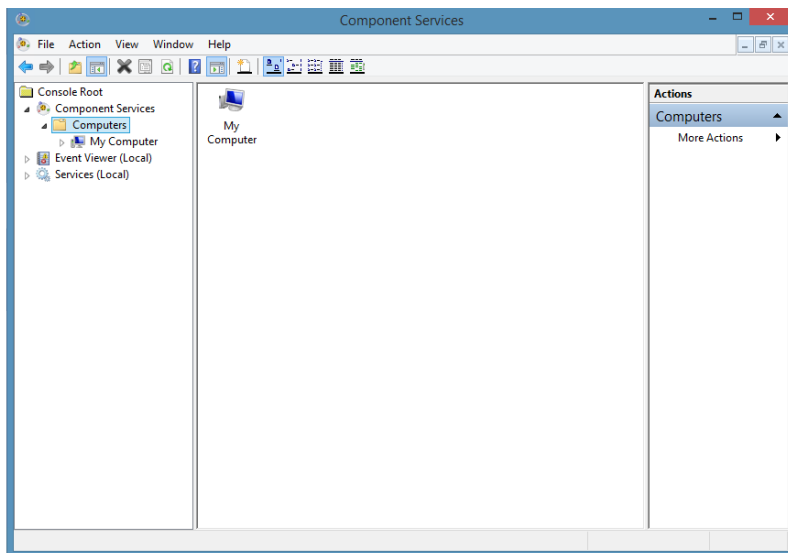

Preparing for Automation

Configuring DCOM Access to Your Unit

4. Right-click **My Computer**, and then select **Properties**.
5. In the **My Computer Properties** dialog box, tap the **Default Properties** tab.
6. Select **Enable Distributed COM on this computer**.

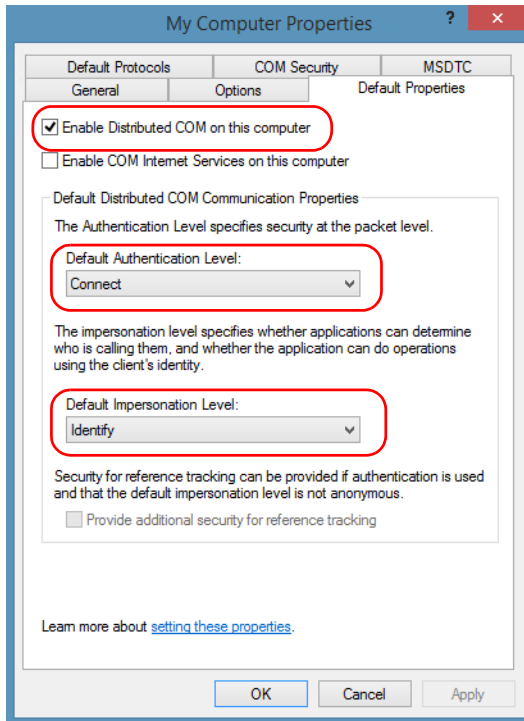

7. Under **Default Distributed COM Communication Properties**, in the **Default Authentication Level** list, select **Connect**.
8. In the **Default Impersonation Level** list, select **Identify**.
9. Tap **Apply**.

10. Tap the **COM Security** tab and, under **Access Permissions**, tap **Edit Limits**.

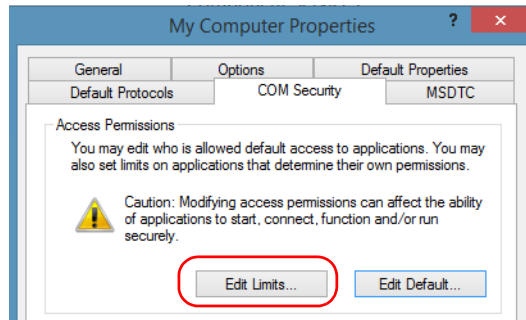

11. In the Access Permission dialog box, ensure that, for **ANONYMOUS LOGON**, local and remote accesses are allowed.
If **ANONYMOUS LOGON** is not listed under Group or user names, tap **Add** to add it.

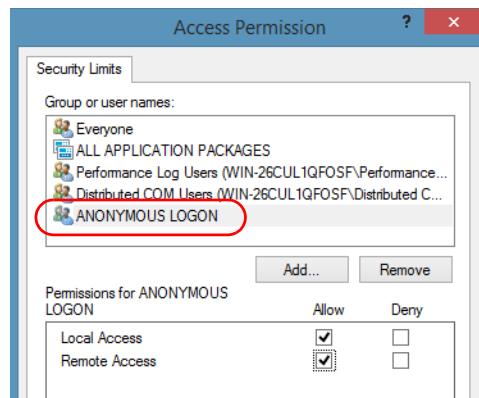

For more information on enabling events with DCOM, refer to *AppId Key* in MSDN Documentation.

Preparing for Automation

Configuring DCOM Access to Your Unit

Disabling DCOM Access to Your Unit

Note: To change the DCOM access to your unit, you need Administrator access rights.

If you no longer want client computers to access your unit using DCOM, you can disable this access.

To disable DCOM access to your unit:

1. From the main window, tap the **System Settings** button.
2. Tap **Control Panel**.
3. Tap **System and Security > Administrative Tools**.
4. Double-tap **Component Services**.
5. From the **Component Services** window, select: **Console Root > Component Services > Computers > My Computer > DCOM Config** to show the contents of the **DCOM Config** folder.

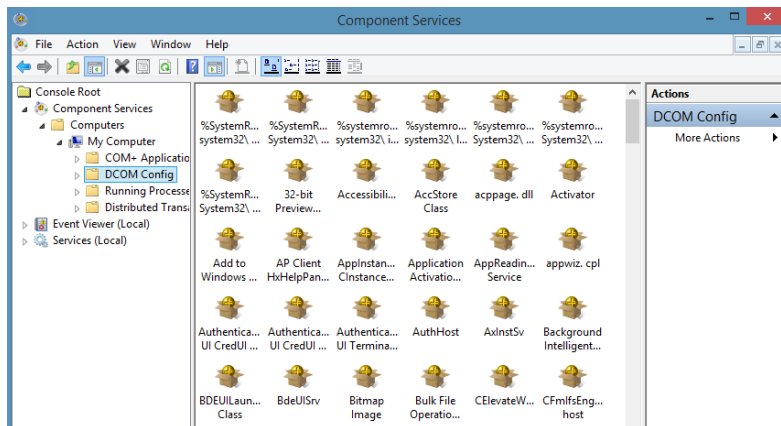

6. From **DCOM Config**, right-click **EXFO KernosHost**, and select **Properties**.

7. In the **EXFO KernosHost Properties** dialog box, tap the **Security** tab.
8. Under **Launch and Activation Permissions** and **Access Permissions**, select **Use Default**.

This ensures the EXFO IcSCPIAccess Class component uses the default lists instead of the customized lists.

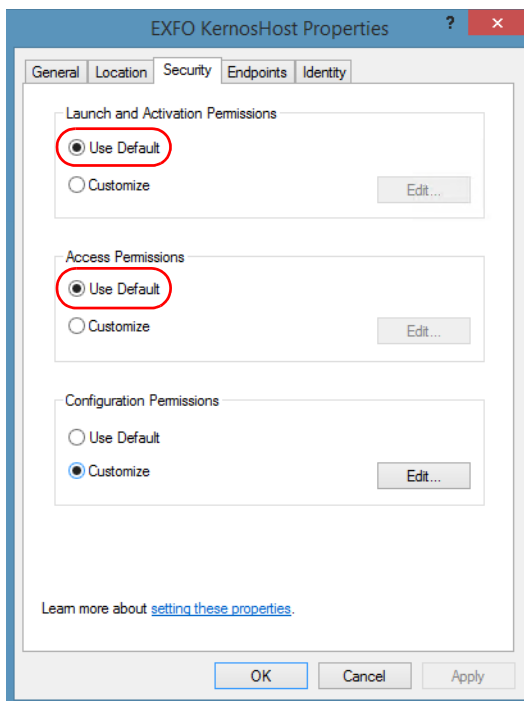

9. Tap **OK**.
10. Restart your unit.

The EXFO IcSCPIAccess Class component, located on your unit, *cannot* be accessed with DCOM.

Preparing to Control Modules with a Dedicated Application

Some modules come with a dedicated application designed to control them remotely from a computer. The main characteristic of this application is that it lets another user control the module exactly as if he had it close at hand.

To control the module remotely, you must configure it on the unit containing the module, including a description that can help you identify it. The user controlling the module from a computer must install the dedicated application (for more information on the installation, refer to the application documentation).

- The module can be controlled both remotely and locally at the same time.
- You will have to configure your remote control again in the following cases:
 - you inserted the module in another slot
 - you applied changes on applications while the module is not inserted in its slot.

Note: *Some modules do not support the remote control.*



IMPORTANT

If there is a network failure or a problem with your remotely-controlled module, you can shut down the latter without closing all the other applications. The local and remote module session will then be closed.

To activate or deactivate remote control:

1. From the main window, tap the **System Settings** button.
2. Tap **Remote Control Configuration**.

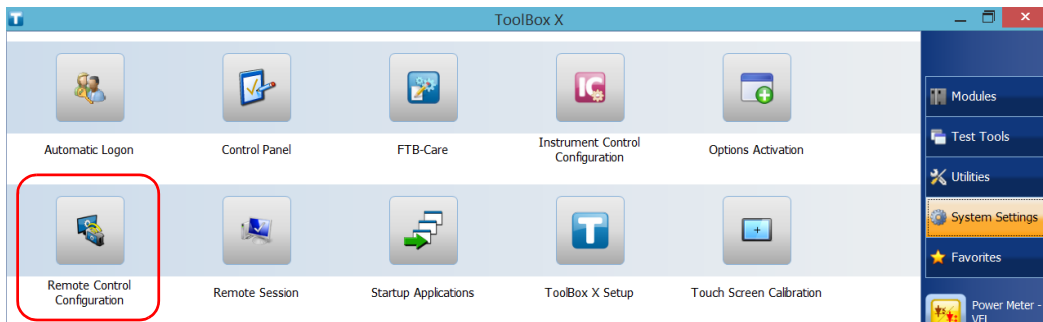

3. If necessary, tap **Change settings**, and then, when the application prompts you to authorize the changes to your unit (identified as “computer”), select **Yes**.

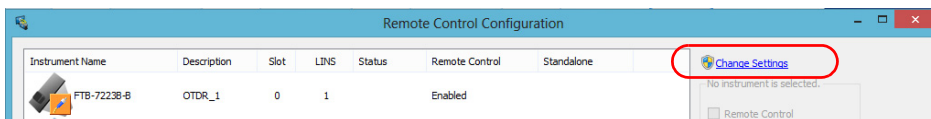

Preparing for Automation

Preparing to Control Modules with a Dedicated Application

4. From the **Remote Control Configuration** window you will see all the inserted modules. Select the module for which you want to have a remote access.

Note: *Modules for which remote control is not supported are identified as unrecognized.*

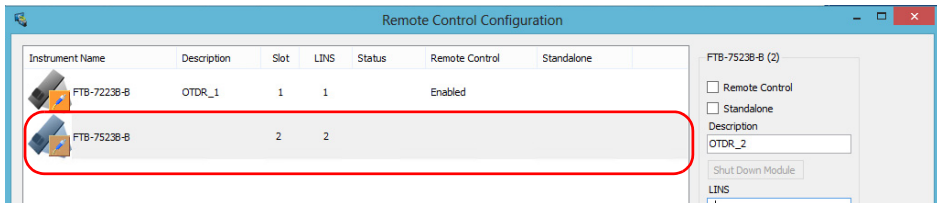

5. Set the parameters:
 - Select **Remote Control** to let another user control the module from a computer.
 - Select **Standalone** to leave the module active even if all users close their dedicated applications.
6. If desired, under **Description**, type a description that will help you identify the instrument.

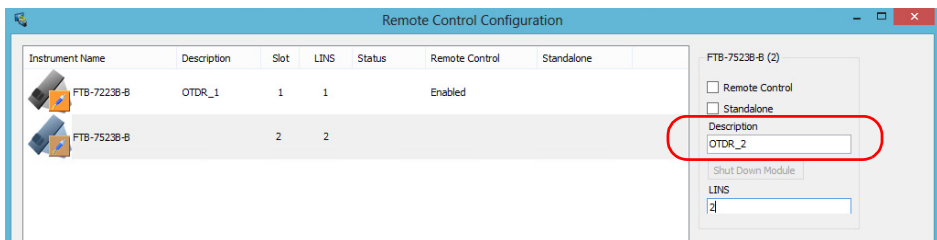

Note: *You can enter up to 10 characters. The description can correspond to the test interface ID or to any other short text of your choice.*

Preparing for Automation

Preparing to Control Modules with a Dedicated Application

7. If necessary, under **LINS**, modify the logical instrument number that you will use to access the instrument remotely.

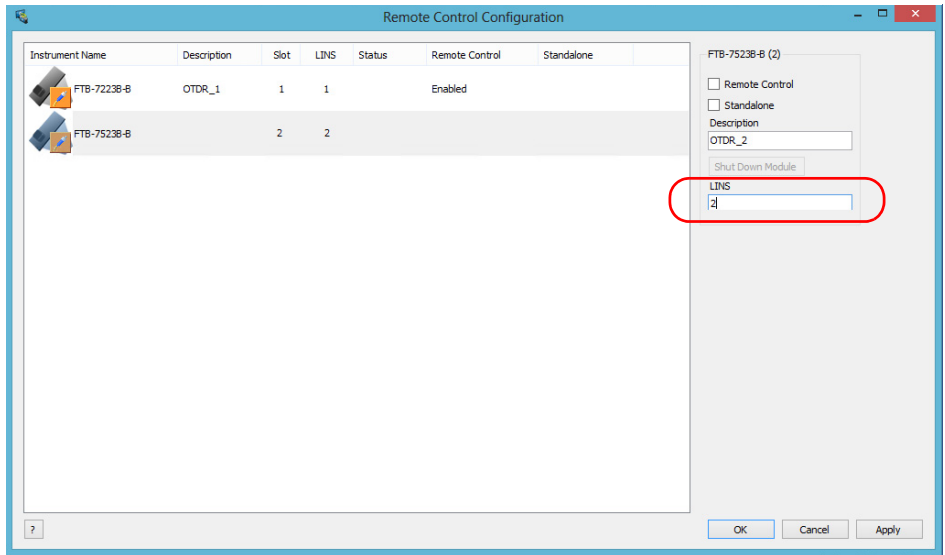

8. Tap **Apply** to confirm your changes or **OK** to apply your changes and close the window.

Note: *This information will be updated the next time you start the module application and will appear in the title bar if the module application allows it. Refer to the corresponding module documentation for more details.*

Preparing for Automation

Preparing to Control Modules with a Dedicated Application

To shut down the remotely-controlled module:

Tap Shut Down Module.

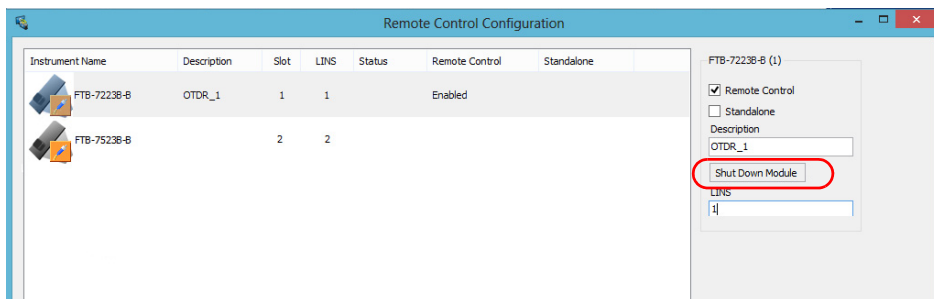

12 ***Using Your Unit and Modules in an Automated Test Environment***

EXFO supplies commands that follow the guidelines determined by the SCPI consortium for all available instruments. EXFO also supplies COM properties and events allowing you to build your own application.

The present chapter gives you information to help you use the provided commands as well as COM properties and events to remotely control your instruments.

If you need information on how to prepare your unit for remote control, see the corresponding section in this documentation.

Note: *To have access to automation features on an FTB-2 unit, you must purchase the Automation option.*

Standard Status Data Structure

Each device that is physically connected to the remote bus has four status registers with a structure complying with the IEEE 488.2 standard. These registers allow the controller to monitor events and get useful information on the status of the devices it controls.

- Standard Event Status Register (ESR)
- Standard Event Status Enable Register (ESE)
- Status Byte Register (STB)
- Service Request Enable Register (SRE)

ESR and ESE

The standard event status register and status enable register information is presented in the following table.

Bits	Mnemonics	Bit Value
7	Power On (PON)	128
6	User Request (URQ)	64
5	Command Error (CME)	32
4	Execution Error (EXE)	16
3	Device-Dependent Error (DDE)	8
2	Query Error (QYE)	4
1	Not Used (N.U.)	0
0	Operation Complete (OPC)	1

Using Your Unit and Modules in an Automated Test Environment

Standard Status Data Structure

The following table presents a summary of the possible operations on ESR and ESE registers.

Register	Read	Write	Clear
ESR	Use *ESR?.	Impossible to write.	<ul style="list-style-type: none">▶ Use *CLS.▶ Read the register.
ESE	Use *ESE?.	Use *ESE.	Use *ESE with a value equal to 0.

STB and SRE

The status byte register and service request enable register information is presented in the following table.

Bits	Mnemonics	Bit Value
7	Not Used (N.U.)	0
6	Master Summary Status (MSS)/ Service Request (RQS)	64
5	Event Summary Bit (ESB)	32
4	Message Available (MAV)	16
3	Not Used (N.U.)	0
2	Error Available (EAV)	4
1	Not Used (N.U.)	0
0	Not Used (N.U.)	0

Using Your Unit and Modules in an Automated Test Environment

Standard Status Data Structure

The following table presents a summary of the possible operations on STB and SRE registers.

Register	Read	Write	Clear
STB	<ul style="list-style-type: none">▶ Use *STB?.▶ Use serial poll (GPIB bus sequence that allows retrieval of the value without interrupting the current process).	Impossible to write; the register content is only modified when the Event registers or Queues are modified.	Use *CLS before sending a query (to clear the Event registers and Queues and by the same token clear the STB register).
SRE	Use *SRE?.	Use *SRE with a value equal to 0 to disable the register or with a value equal to 1 to enable it.	<ul style="list-style-type: none">▶ Use *SRE with a value equal to 0.▶ At startup, the register is set to 0.

The diagram displayed on the next page is a useful aid in understanding the general commands and how a service request (SRQ) is generated.

Using a service request, a device notifies the controller that an event requiring special attention occurred. The controller will then find which device generated a SRQ (its RQS bit is set) and the causes of it.

Using Your Unit and Modules in an Automated Test Environment

Standard Status Data Structure

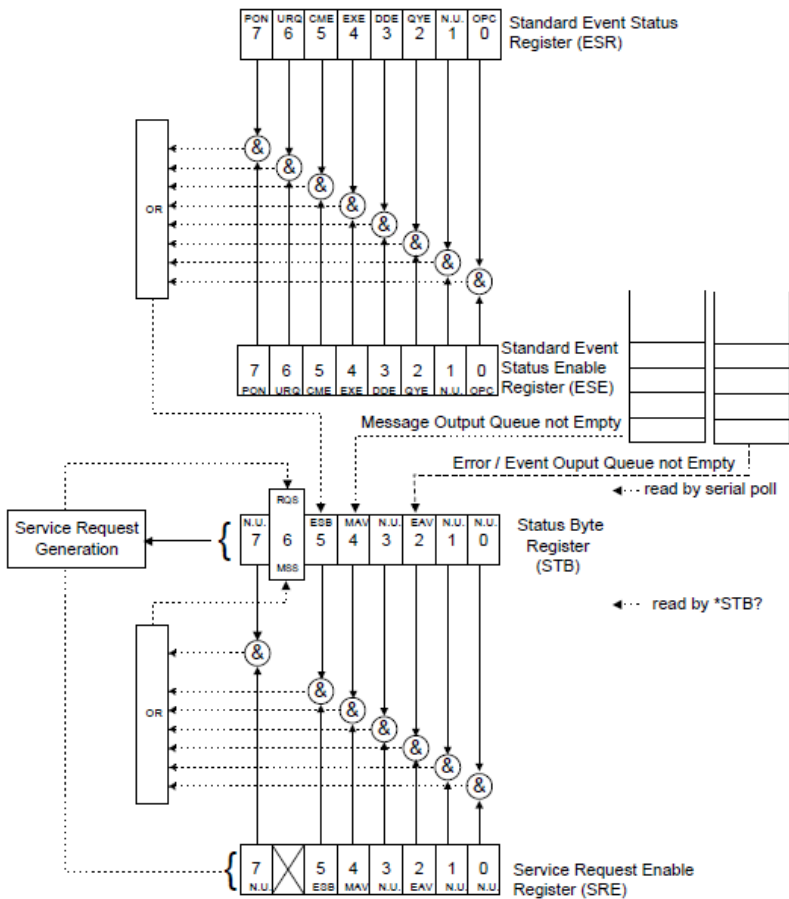

SCPI Command Structure

The information presented in this section provides an overview of SCPI programming. If you need detailed information, refer to:

- The International Institute of Electrical and Electronics Engineers. *IEEE Standard 488.2-1992, IEEE Standard Codes, Formats, Protocols and Common Commands For Use with ANSI/IEEE Std. 488.1-1987*. New York, 1992.
- *Standard Commands for Programmable Instruments (SCPI). Volume 1: Syntax and Style*. Vers. 1999.0 May, U.S.A, 1999.

The provided commands follow the guidelines determined by the Standard Commands for Programmable Instruments (SCPI) consortium. A *program message* consists of one or more commands (and/or queries) with their appropriate parameters.

For example, a program message could contain a command used to activate or deactivate a source. The corresponding command syntax would be:

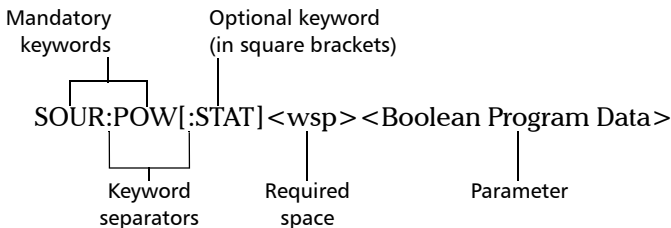

When sending a message containing the previous command, you would actually type: `SOUR:POW ON`.

The following table shows elements that are commonly used in the commands or queries syntax.

Item	Meaning
[]	Enclose optional keywords or parameters. <i>Do not include square brackets in your program message.</i>
[1..n]	Indicates that the instrument provides multiple capabilities and that you have to specify which one you want to use. If you omit the value, the command will take effect on the first capability. Multiple capabilities can be found at any branch of the command tree (root, intermediate node or terminal node). Example: If the command is :SENSe[1..n]:CORRection:COLLect:ZERO and you want it to take effect on the second SENSE (sensor) capability of the instrument, you may send this: :SENSe2:CORRection:COLLect:ZERO. <i>Do not include square brackets in your program message; simply enter the number.</i>
<wsp>	Indicates that a space is required (“wsp” stands for “white space”). Corresponds to ASCII character codes (0 to 9 and 11 to 32, in decimal). <i>Do not include “<wsp>” in your program message; simply type a space.</i>
<digit>	Element used in the construction of various numeric data types. Can take any value between 0 and 9 inclusively (corresponds to ASCII character codes 48 to 57, in decimal).

Using Your Unit and Modules in an Automated Test Environment

SCPI Command Structure

Item	Meaning
<mnemonic>	<p>Element used in the construction of certain data types and program messages.</p> <div data-bbox="444 354 982 574" data-label="Diagram"> </div> <p>In the diagram above,</p> <ul style="list-style-type: none"> ➤ “<Upper/lower case alpha>” corresponds to ASCII character codes (65 to 90 and 97 to 122, in decimal). ➤ “_” corresponds to an underscore character (code 95, in decimal).
< >	<p>Text appearing between angled brackets specifies the command parameter to be sent or the response you will receive from an instrument.</p> <p><i>Do not include angled brackets in your program message.</i></p>
	<p>Indicates that one, and only one, value must be selected from the available choices.</p> <p>Example: If the list is 0 1, you can only select 0 or 1.</p> <p><i>Do not include the pipe character in your program message.</i></p>
{ }	<p>Indicate that the enclosed parameters can appear 0 to n times when the command is used.</p> <p><i>Do not include braces in your program message.</i></p>
:	<p>Mandatory to separate keywords. Can be omitted at the beginning of a program message. For example, you can use either :SYST:ERR or SYST:ERR.</p>

Item	Meaning
;	<ul style="list-style-type: none"> ➤ Mandatory to separate the different commands of a program message when more than one command is sent at a time. In this case, it is called <i><PROGRAM MESSAGE UNIT SEPARATOR></i>. ➤ Also used to separate responses when multiple queries were sent in a single program message. In this case, it is called <i><RESPONSE MESSAGE UNIT SEPARATOR></i>.
,	<ul style="list-style-type: none"> ➤ Mandatory to separate parameters in a command or a query. In this case, it is called <i><PROGRAM DATA SEPARATOR></i>. ➤ Also used to separate the various responses from a query. In this case, it is called <i><RESPONSE DATA SEPARATOR></i>.

There are also several conventions regarding command syntax:

- Spelling errors will cancel the command or query.
- Commands and queries are not case-sensitive. You can type your program messages using either lower-case or upper-case letters.
- The command or query can be written using only the three- or four-letter shortcuts, only full words, or a combination of both.

The example below shows the long and the short forms of a same query.

:SYSTem:ERRor?		Long form
:SYST:ERR?	}	Short form (small words represented by the capital letters of the long form)
:syst:err?		

Consulting Data Types

If you need information about data types used in EXFO's documentation, see the appendix on data types.

Writing Remote Control Code

Your unit offers many commands permitting complete remote control of all the supported FTB components. These commands adhere to the SCPI standard.

You can find all the commands and queries supported by your unit in the *IEEE 488.2 and Specific Commands* appendix. For information on commands specific to particular instruments, refer to the instrument's user guide.

When you write code, you must follow these rules on message reception and transmission:

- The controller must have sent a complete message to the instrument (including the message terminator) before retrieving a response.
- The controller must retrieve all the responses from previous queries (including the response terminator) before sending a new message to an instrument.
- The controller must not try to retrieve a response from an instrument if the corresponding query has not been previously sent to the instrument.
- You must pay special attention to queries that return an indefinite ASCII response. To avoid any confusion, the IEEE 488.2 standard requires that this data type be immediately followed by a response termination character. For this reason, when working with compound queries, you must ensure that a query sending an indefinite ASCII response is the last query of the series.
- Be careful when sending program messages containing multiple queries that return large amounts of data. Since the controller can only retrieve data when the instrument has finished processing the queries, it could result in problems ranging from a saturation of the output queue to the complete blocking of the whole system.

Error Message Format

System and device-specific errors are managed by your unit. The generic format for error messages is illustrated in the following figure.

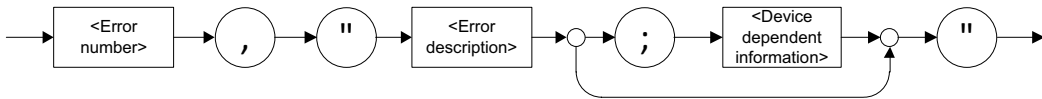

As shown in the above figure, the message contains three parts:

- error number
- error description
- device-dependent information

Error messages ending in a negative number are SCPI-based errors.

For a complete list of possible errors, see the appendix on SCPI-based errors.

Monitoring Remote Commands

ToolBox X allows you to monitor remote commands sent to your units, if desired.

To monitor remote commands:

1. From the main window, tap the **Test Tools** button.
2. Depending on which type of communication protocol you are using, select **IC Monitor** or **SCPI Telnet Monitor**.

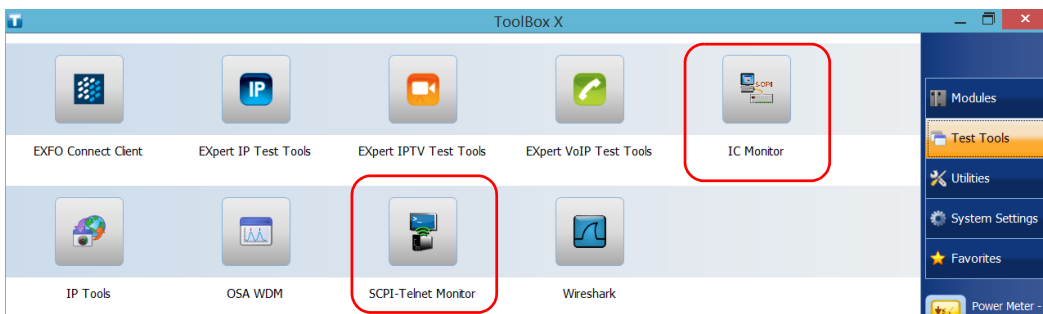

Using Your Unit and Modules in an Automated Test Environment

Monitoring Remote Commands

3. Do one of the following:

- If monitoring using ActiveX or RS-232, click **Connect to IC**.

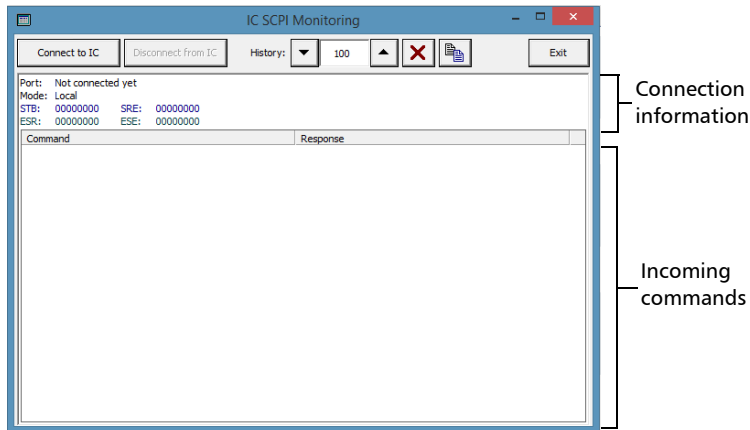

You are automatically connected to the monitoring system. The **Disconnect from IC** button becomes available for you when you are ready to disconnect.

Once connected, your current connection information will appear in the upper part of the window, and the commands will appear as a list in the lower part of the window.

With the **History** parameter, you determine how many commands you want to keep in the list. You can change the number by using the arrow buttons on each side of the list.

To clear the history, click .

To view the list in any word processor, click  to copy it to the clipboard, and then paste it in your document. You can use any program, as the list is copied in text format.

To exit the monitoring utility, click **Exit**.

For more information, see the section on using your unit in an automated test environment.

Using Your Unit and Modules in an Automated Test Environment

Monitoring Remote Commands

- If monitoring using TCP/IP, which provides sending SCPI commands over TCP/IP through Telnet from the EXFO Instrument Control, you are automatically connected to the monitoring system.

Note: Port 5024 is designated for sending SCPI commands in the Telnet protocol.

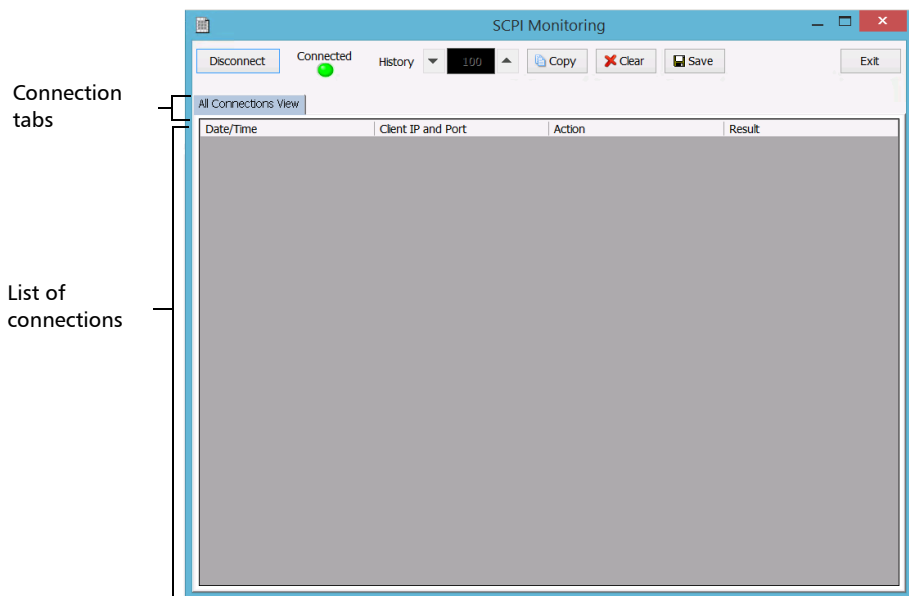

Once connected, your current connection information will appear in the **All Connections View** tab, and the commands will appear as a list in the lower part of the window.

The **Disconnect** button becomes available for you to click when you are ready to disconnect.

Connection information is also displayed in a separate tab, identified by its IP address, from where you can monitor the commands and other actions sent through TCP/IP over Telnet, as well as the results.

Using Your Unit and Modules in an Automated Test Environment

Monitoring Remote Commands

With the **History** parameter, you determine how many commands you want to keep in the list. You can increase or decrease the number by using the arrow buttons on each side of the list.

To clear the history, click **Clear**.

To view the list in any word processor, click **Copy** to copy it to the clipboard, and then paste it in your document. You can use any program, as the list is copied in text format.

To save the list as a file, click **Save**.

To exit the monitoring utility, click **Exit**.

For more information, refer to the user documentation about communication through TCP/IP over Telnet.

13 *Maintenance*

To help ensure long, trouble-free operation:

- Always inspect fiber-optic connectors before using them and clean them if necessary.
- Keep the unit free of dust.
- Clean the unit casing and front panel with a cloth slightly dampened with water.
- Store unit at room temperature in a clean and dry area. Keep the unit out of direct sunlight.
- Avoid high humidity or significant temperature fluctuations.
- Avoid unnecessary shocks and vibrations.
- If any liquids are spilled on or into the unit, turn off the power immediately, disconnect from any external power source, remove the batteries and let the unit dry completely.



WARNING

The use of controls, adjustments and procedures, namely for operation and maintenance, other than those specified herein may result in hazardous radiation exposure or impair the protection provided by this unit.

Cleaning Detector Ports

Regular cleaning of detectors will help maintain measurement accuracy.



IMPORTANT

Always cover detectors with protective caps when unit is not in use.

To clean detector ports:

1. Remove the protective cap and adapter (FOA) from the detector.
2. If the detector is dusty, blow dry with compressed air.
3. Being careful not to touch the soft end of the swab, moisten a cleaning tip with *only one drop* of isopropyl alcohol.



IMPORTANT

Alcohol may leave traces if used abundantly. Do not use bottles that distribute too much alcohol at a time.

4. While applying light pressure (to avoid breaking the detector window), gently rotate the cleaning tip on the detector window.
5. Repeat step 4 with a dry cleaning tip or blow dry with compressed air.
6. Discard the cleaning tips after one use.

Cleaning VFL-Type Connectors

VFL-type connectors are fixed on your unit and can be cleaned using a mechanical cleaner.



WARNING

Verifying the surface of the connector with a fiber-optic microscope WHILE THE UNIT IS ACTIVE WILL result in permanent eye damage.

To clean a connector using a mechanical cleaner:

1. Insert the mechanical into the optical adapter, and push the outer shell into the cleaner.

Note: *The cleaner makes a clicking sound to indicate that the cleaning is done.*

2. Verify connector surface with a portable fiber-optic microscope (for example, EXFO's FOMS) or fiber inspection probe (for example, EXFO's FIP).

Maintenance

Cleaning the Touchscreen

Cleaning the Touchscreen

Clean the touchscreen with a soft, non-abrasive cloth, such as one used for cleaning reading glasses, dampened with water.



CAUTION

Using anything else than water can damage the special coating used for units equipped with an outdoor-enhanced screen (S2 option).

When not using your unit, EXFO recommends using the screen protector that came with it.

Recharging the Batteries

Your unit uses smart lithium-ion (Li-Ion) batteries. The number of batteries that power your unit and that come with it depends on the model that you have purchased.

The table below gives detailed information.

Model	Number of batteries that power the unit	Number of batteries provided with the unit
FTB-2	1 Battery must be inserted in the first battery slot (use the markings at the back of the unit to guide you). The second battery slot does not power the unit. It only serves as storage for an extra battery that you would swap in the first battery slot when required.	1 You can purchase an extra battery and store it in the second battery slot.
FTB-2 Pro	2	2

- The charge status is shown in the taskbar (at the left of the clock). Simply tap the battery icon for more information.
- The unit also indicates the charge status with the LED on its front panel (see *LED Indicators Description* on page 10).



CAUTION

Only charge the batteries with the AC adapter/charger provided by EXFO with your unit.

Maintenance

Recharging the Batteries



IMPORTANT

- ▶ Batteries are not charged at the factory. You must fully charge them before using the unit for the first time. The batteries are fully charged after a few hours or when the battery LED indicator stops flashing.
- ▶ The time required to charge batteries depends on various factors such as the type of modules currently in use and the ambient temperature.
- ▶ To ensure that batteries function or charge properly, keep them in temperatures between 0 °C and 40 °C (32 °F and 104 °F). Store them between -20 °C to 60 °C (-4 °F to 140 °F).
- ▶ Do not leave a battery discharged for several days.
- ▶ Depending on the way the unit is used, after a while, the charge status icon may no longer correspond to the actual power level of the battery (for example, the icon indicates that the power level is sufficient, but the unit turns off because the battery is too weak).
- ▶ After 300 cycles (approximately 18 months of use), you may want to replace the batteries with new ones to maintain optimal operation conditions. Otherwise, the operating time might be reduced.



IMPORTANT

- Remove the batteries if the unit will not be used for more than two weeks.
- If you need to store the batteries for an extended period of time, place them in a cool dry place, and ensure that they are charged at around 50 % of their capacity. Every three months during the storage period, verify the battery level. Recharge the batteries when necessary, so that their charge level remains around 50 % of the total capacity. This will ensure that you get the optimum performance out of the batteries.

To recharge the batteries:

Connect the unit to a power outlet using the AC adapter/charger. The charge cycle will start and end automatically.

Replacing Batteries

Your unit can be powered either by batteries or from an appropriate power outlet when used with the provided AC adapter/charger.



WARNING

Do not throw batteries into fire or water and do not short-circuit the battery electrical contacts. Do not disassemble.



CAUTION

Your unit uses smart lithium-ion (Li-Ion) batteries with built-in protection that have been especially designed for EXFO. For this reason, you can only replace them with batteries of the same type and model.

The use of other batteries may damage your unit and compromise your safety.

For more information on the available power sources for your unit, as well as their characteristics, see *Technical Specifications* on page 327.

Before you go out in the field, make sure you install batteries in the unit unless you have an adequate and reliable power source.

To replace the batteries in the unit:

- 1.** Open the battery compartment as follows:
 - 1a.** Position the unit so that its front panel rests on a flat surface such as a table.
 - 1b.** Lift the unit's support to have a complete access to the battery compartment.
 - 1c.** Lift the mobile part of the battery compartment screws and turn the screws counterclockwise until the compartment door is loose. Since they are captive screws, you cannot remove them completely.

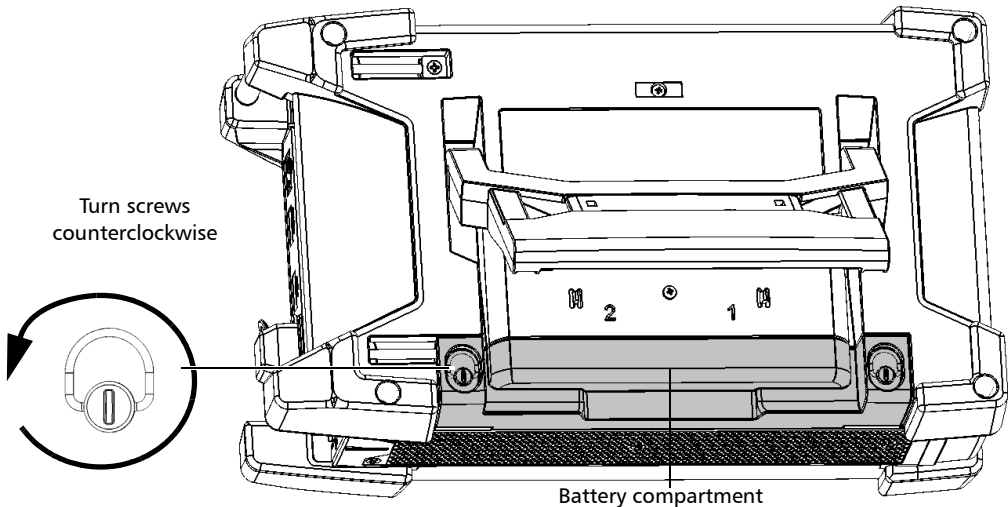

- 1d.** Remove the battery compartment door.

Maintenance

Replacing Batteries

2. Use the markings on the back panel to locate the battery that you want to replace, and then pull on the battery's tab to free it from its socket.

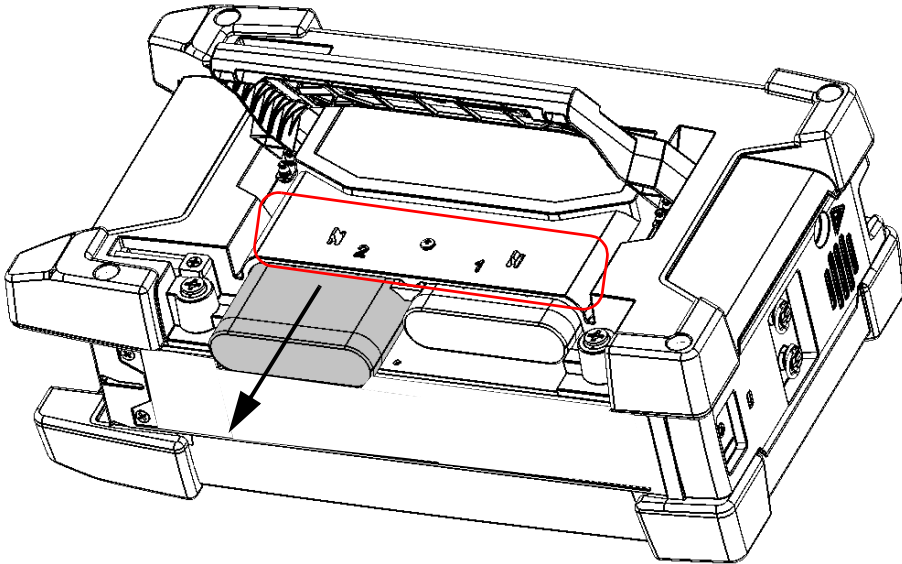

IMPORTANT

On the FTB-2 units, the second battery slot does not power the unit. The battery must be inserted in the first battery slot.

- 3.** Install the new battery as follows:
 - 3a.** Place the battery so that its poles are facing down and that they point towards the back of the battery socket.

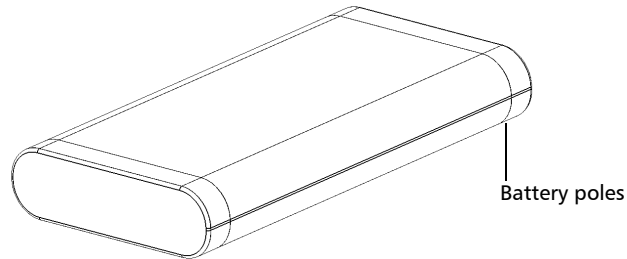

- 3b.** Slide in the new battery, and push it toward the back until it stops.

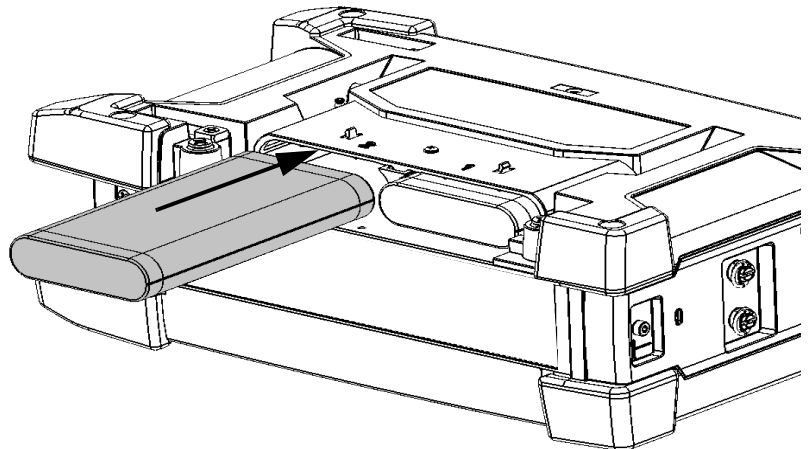

- 4.** Repeat steps 2 and 3 with the other battery if it also needs replacement (FTB-2 Pro only).
 - 5.** Position the battery compartment door so that you can see its two screws.

Maintenance

Replacing Batteries

6. Place the battery compartment on the unit, making sure that the sides of the compartment are flush with the back of the unit. If necessary, slightly move the battery compartment door until alignment is correct.

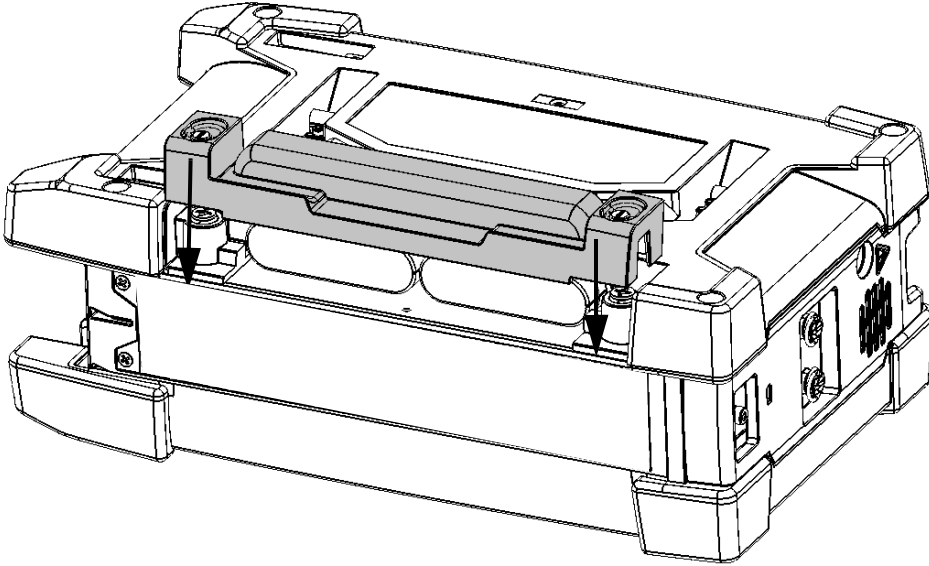

7. Lift the mobile part of the compartment screws and, while applying slight pressure, turn the screws clockwise until they are tightened.

Installing or Removing the Power Meter and VFL

If your unit was not equipped with a power meter and a VFL at time of your initial purchase, you can purchase one afterwards and install it yourself.

You may also need to remove the power meter to send it to an authorized service center for recalibration.

Note: *If you prefer not to remove the power meter from your unit when a calibration is needed, you can also send the complete unit to the service center.*



WARNING

- To avoid serious injuries as well as irreparable damages both to your unit and your power meter, **ALWAYS TURN OFF YOUR UNIT** (shutdown mode, not sleep), **DISCONNECT IT FROM THE EXTERNAL POWER SOURCE**, and **REMOVE ALL BATTERIES**. For more information on the ways to turn off your unit, see *Turning Off Your Unit* on page 49.
- Be careful not to drop metal objects such as screws inside the unit. These could cause a short-circuit leading to a fire or an explosion.

Maintenance

Installing or Removing the Power Meter and VFL



CAUTION

Electrostatic discharge (ESD) damage can cause complete or intermittent equipment failures.

- Always use an ESD-preventive wrist or ankle strap when handling the power meter. Ensure that the antistatic strap makes good skin contact and that the end of its wire is grounded properly.
- Always handle the power meter by the edges of its metal faceplate (where the detector port is located).
- Never touch the circuit board.
- Keep any piece of clothing away from the power meter during the handling.
- Never touch any component inside the unit either with tools or your fingers.
- Only place the power meter on antistatic surfaces such as an antistatic mat, and quickly put power meters that need recalibration into antistatic bags.



CAUTION

Use only power meters and VFL designed for your unit and approved by EXFO.

To install a power meter:

1. Turn off your unit.
2. Disconnect the unit from its external power source and remove the batteries.
3. Put on a wrist (or an ankle) antistatic strap and ensure that the end of its wire is grounded properly.

4. Place the unit vertically so that its right panel is facing you, and then locate the protective cover that hides the power meter bay.

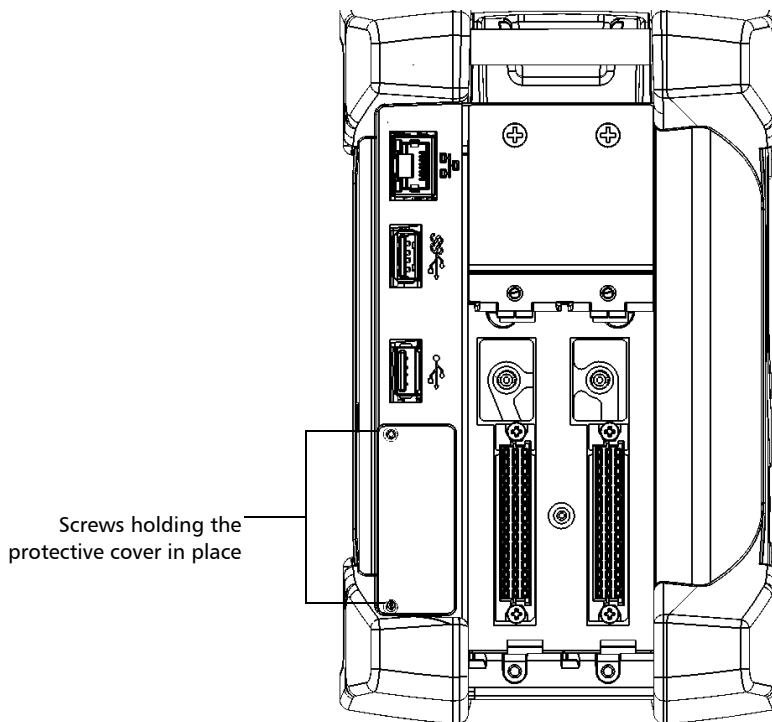

5. Using a screwdriver, remove the two screws of the protective cover.

Note: *Keep the screws close at hand because you will need them to secure the power meter in place later.*

6. Remove the protective cover.



IMPORTANT

Do not discard the protective cover. You will need it to protect the power meter bay if you ever send the power meter for recalibration.

Maintenance

Installing or Removing the Power Meter and VFL

7. By holding the power meter by its faceplate, position it so that the writings are right-side up.

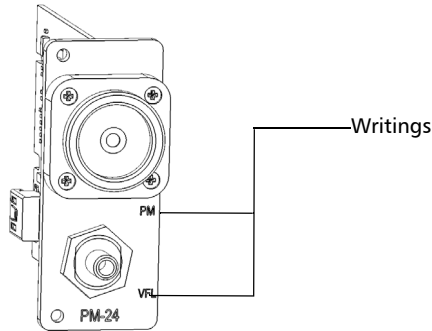

8. Carefully align the power meter with the corresponding bay.

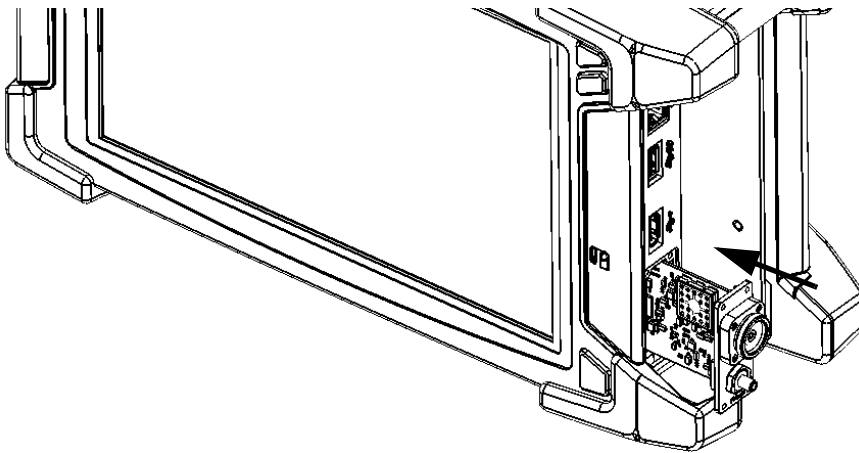

9. Gently slide the power meter into the bay until its faceplate is flush with the edge of the bay. As the power meter reaches the back of the bay, you should feel a slight resistance, indicating that it is properly connected inside the unit.

Note: *If the power meter slides all the way into the bay without any resistance, it probably means that it is not properly inserted.*

- 10.** Using a screwdriver, secure the power meter in place with the screws that you have removed at step 5.
- 11.** Remove your antistatic strap.
- 12.** Connect your unit to an external power source if desired.
- 13.** If it is not already done, turn on your unit.
- 14.** Start the power meter application to ensure that the instrument is working properly.

Note: *If the power meter is not detected, this could mean that it is not inserted properly in the unit. In this case, repeat the installation procedure. If the problem persists, contact EXFO.*

Maintenance

Installing or Removing the Power Meter and VFL

To remove the power meter for recalibration:

1. Turn off your unit.
2. Disconnect the unit from its external power source and remove the batteries.
3. Put on a wrist (or an ankle) antistatic strap and ensure that the end of its wire is grounded properly.
4. Place the unit vertically so that its right panel is facing you, and then locate the power meter.
5. Using a screwdriver, remove the two screws of the power meter.

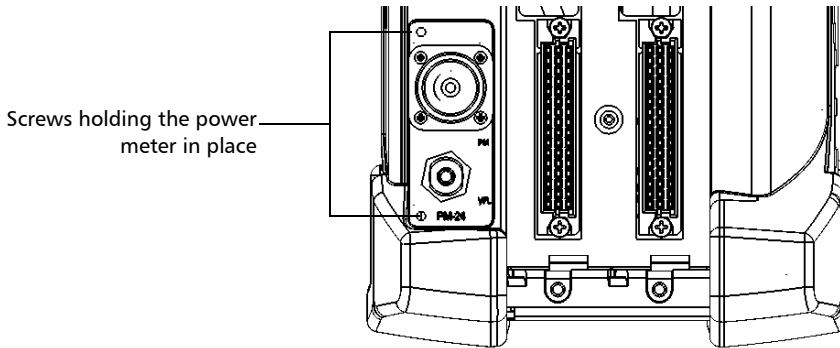

Note: *If you have a protective cover for the power meter bay, keep the screws close at hand. You will need them to secure the protective cover in place later.*



IMPORTANT

Do not discard the screws. You will need them to secure the protective cover, and the power meter in its bay when it is back from calibration.

6. By holding the power meter by its faceplate, gently pull it out of the bay completely.

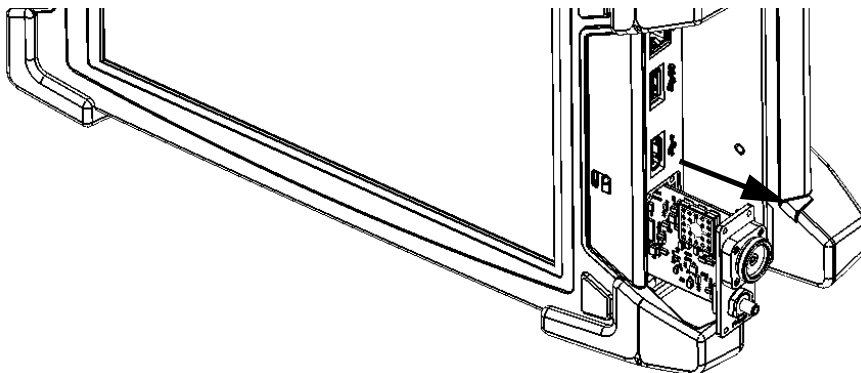

7. Place the power meter in an antistatic bag.
8. If you have a protective cover, proceed as follows:
 - 8a. Carefully place the cover over the power meter bay.
 - 8b. Using a screwdriver, secure the protective cover in place with the screws that you have removed at step 5.
9. Remove your antistatic strap.
10. Connect your unit to an external power source if desired.

Managing Windows Updates

By default, your unit is configured to check for updates, but to let you choose whether you want to download and install them or not.

However, if you prefer, you can configure your unit to automatically search and install Windows updates to ensure that you benefit from the latest versions of the Windows applications. Your unit will need an Internet access for the updates.

Only the applications from Microsoft will be updated with the automatic Windows update feature. If you want to update EXFO applications, see *Installing or Upgrading the Applications* on page 63. The third-party applications will need to be updated manually.

To manage the updates for Windows applications:

1. From the main window, tap the **System Settings** button.
2. Tap **Control Panel**.



3. Tap System and Security.

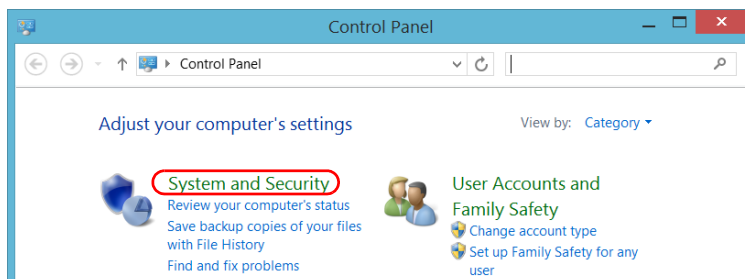

4. Under Windows Update, tap Turn automatic updating on or off.

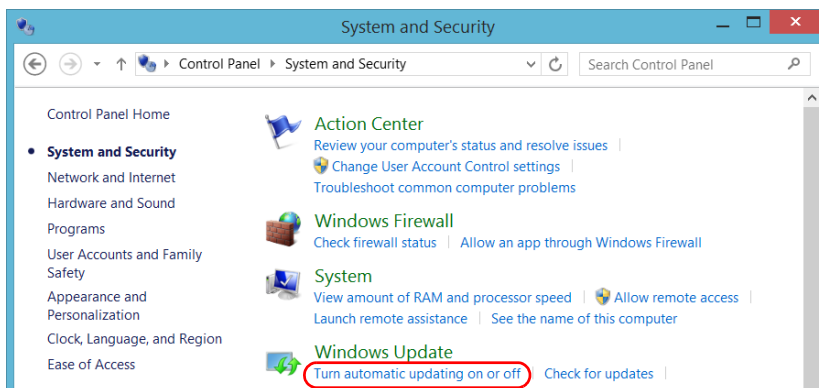

Maintenance

Recycling and Disposal (Applies to European Union Only)

5. Select the update options that best suit your needs.

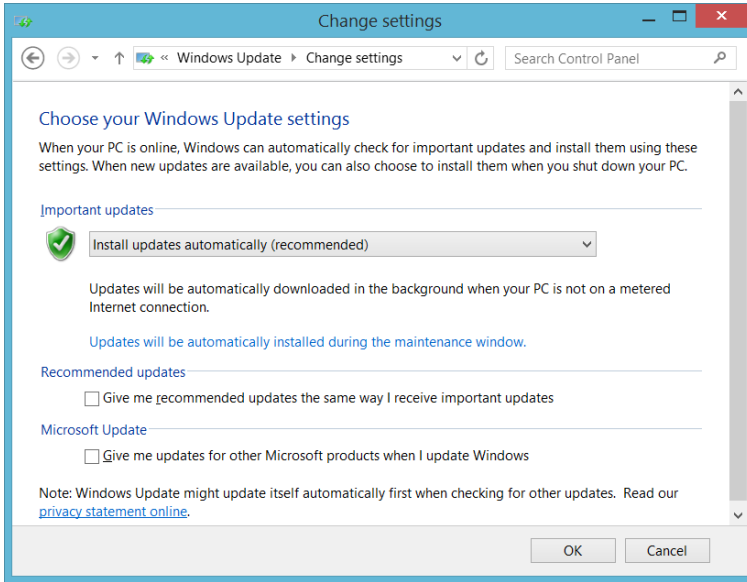

6. Tap **OK** to confirm your changes and return to Control Panel.

Recycling and Disposal (Applies to European Union Only)

For complete recycling/disposal information as per European Directive WEEE 2012/19/UE, visit the EXFO Web site at www.exfo.com/recycle.

14 *Troubleshooting*

Solving Common Problems

Before calling EXFO's technical support, you may want to consider the following solutions to problems that could occur.

Problem	Possible Cause	Solution
My unit does not start.	It is not connected to a power source.	Make sure that the external power supply is connected at both ends.
	Batteries are completely discharged.	Change or recharge the batteries.
	The system has encountered a problem.	Press the On/Off button for at least fifteen seconds to force a hardware reset on the unit.
	Windows startup files have been corrupted.	Contact EXFO.

Troubleshooting

Solving Common Problems

Problem	Possible Cause	Solution
My unit is running slower than expected.	The configuration of some of the Windows components is underway in the background.	<p>The first few times that you start your unit, after a reset operation, or after certain updates, you may notice that the performance of your unit is not optimum.</p> <p>If this is the case, you may want to leave your unit idle for about an hour to give Windows the time to complete its configuration tasks.</p>
My unit is not responding.	The system has encountered a problem.	Press the On/Off button for at least fifteen seconds to force a hardware reset on the unit.
The screen does not keep its calibration. OR The screen is hard to calibrate properly.	The screen was calibrated using the tool provided with Windows instead of the tool provided with ToolBox X.	<ul style="list-style-type: none">➤ From the Control Panel, go to Hardware and Sound > Tablet PC Settings.➤ Tap Reset.➤ If you need to perform further adjustments to the calibration, from ToolBox X, tap System Settings > Touch Screen Calibration.

Problem	Possible Cause	Solution
The USB device I have just connected is not working.	The device has not been detected.	Disconnect, then reconnect the device. Turn off the unit, then turn it on again.
	You do not have the proper driver for this device.	Ensure that you have the right driver (can be provided with the device itself).
The unit does not recognize a test module.	Module application is not installed.	Install the corresponding application using the Update Manager application.
	Defective module.	If the unit recognizes other modules, the faulty module could be defective. Return it to EXFO for repairs.
	Module is not supported on your unit.	Refer to the unit's technical specifications for the complete list of supported modules.

Troubleshooting

Solving Common Problems

Problem	Possible Cause	Solution
The 3G USB modem key is connected, but I am not able to access the Internet.	There is no SIM card in the USB modem key.	Insert the SIM card into the USB modem key. For complete instructions, refer to the documentation that came with your modem key.
	The USB modem key is not detected properly.	Disconnect the modem key from your unit, and try connecting it again. If the modem key is still not detected, try connecting it to another USB port.
	The SIM card has not been activated or there is a problem with service package that you purchased. There is a problem with the mobile network.	Contact your provider of mobile services.
Batteries are not recharging.	Ambient temperature is too high or too low.	Make sure that the temperature in the location where you recharge the batteries is within the specifications
	The AC adapter is not connected properly.	Make sure that the AC power cord is connected to the unit and the AC outlet.

Problem	Possible Cause	Solution
<p>An error message warns me that there is not enough disk space to perform a refresh operation on my unit.</p>	<ul style="list-style-type: none"> ➤ When you perform a refresh operation, Windows creates a folder (<i>Windows.old</i>) in which the files from the previous installation are stored. This folder now uses too much disk space. ➤ The disk needs a cleanup. 	<p>Remove the <i>Windows.old</i> folder or the unused files with the Disk Cleanup utility. For more information, see <i>Freeing Up Disk Space with the Disk Cleanup Utility</i> on page 168.</p>
<p>The Windows interfaces do not switch to the selected language.</p>	<p>On an FTB-2, when you select a language that you have installed manually, the Windows interfaces remain in the language configured at time of purchase. However, the EXFO applications are displayed in the selected language (when available).</p>	<p>Contact EXFO if you think that the language that was configured at time of purchase does not cover your needs.</p>

Troubleshooting

Restoring Your Unit to Normal Operation

Restoring Your Unit to Normal Operation

If you ever encounter major problems with your unit (for example, the unit does not behave the way it used to), you can revert it to a previous state. You can revert your unit either to its initial state (as it was at time of purchase), or to a specific state with a backup image (WIM file) created previously.

Note: *For current updates, use Update Manager.*

You can create your own WIM files directly from your unit and store them on a USB key for future use.



IMPORTANT

The WIM files that you create are based on the serial number of your unit. This means that the WIM files created on one unit are only valid to restore this particular unit.

When you want to restore your unit, there are several options. The table below gives an overview of the possibilities.

Method	Description
Refresh	<ul style="list-style-type: none">➤ The unit will be reverted to its initial state.➤ All data files that were saved to the default personal folders (Documents, Pictures, etc.) will still be available once the operation is complete.➤ If you have installed products and updates since you purchased your unit, you will have to reinstall them.➤ Refer to Microsoft documentation for more information.
Reset	<ul style="list-style-type: none">➤ The unit will be reverted to its initial state.➤ All data files will be lost once the operation is complete.➤ If you have installed products and updates since you purchased your unit, you will have to reinstall them.➤ Refer to Microsoft documentation for more information.
Restore	<ul style="list-style-type: none">➤ The unit will be reverted to the state in which it was when the WIM file was created.➤ All data files will be lost once the operation is complete.➤ If you have installed products and updates since the WIM file was created, you will have to reinstall them.

Troubleshooting

Restoring Your Unit to Normal Operation



CAUTION

- Before starting one of the recovery operations, connect your unit to a power outlet using the provided AC adapter/charger.
- **DO NOT TURN OFF** your unit while the recovery operation is underway. Doing so may severely damage your unit. Damaged units will need to be sent back to EXFO for repair.



IMPORTANT

- **Refresh operation:** All the data that is stored in the default personal folders will still be available once the operation is complete. However, any data stored in other folders will be lost. You may want to back up this data before refreshing your unit.
- **Reset and restore operations:** To avoid losing the data that is stored on your unit, you may want to back it up before resetting or restoring your unit. Otherwise, all your files will be lost.

To revert your unit to a previous state:

1. Ensure that your unit will remain powered on during the operation by connecting it to a power outlet using the provided AC adapter/charger.
2. If desired, back up your data.

Note: *If you want to have a look at the content of the `Windows.old` folder containing files of the previous installation, go to the root of the C drive (Windows (C:)). If you do not see the `Windows.old` folder, it means no refresh operation has ever been performed on your unit.*

3. On an FTB-2, if you intend to refresh your unit and a refresh operation has been performed on it before, remove the existing `Windows.old` folder (with Disk Cleanup). Otherwise, you will receive an error message indicating that the disk space is insufficient and your unit will not be refreshed. For more information on how to remove the `Windows.old` folder, see *Freeing Up Disk Space with the Disk Cleanup Utility* on page 168.

When the cleanup operation is complete, you are ready to perform a refresh operation on your FTB-2 unit.

4. On your unit, from the right side of the screen, swipe left to display the Charm bar.

Troubleshooting

Restoring Your Unit to Normal Operation

5. Tap **Settings > Change PC settings.**

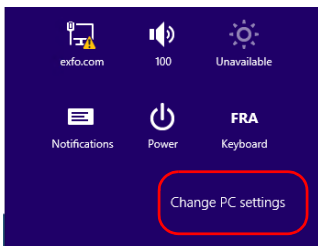

6. On an FTB-2 Pro, tap **Update and recovery.**

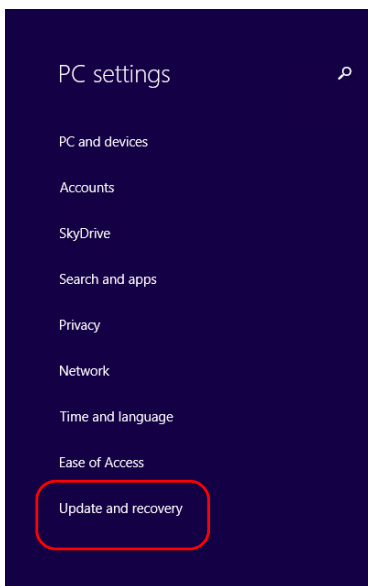

Personalize

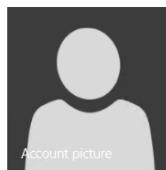

[View recently used settings](#)

7. On an FTB-2 Pro, tap **Recovery**.
On an FTB-2, tap **General**, and then scroll down the list.

FTB-2 Pro

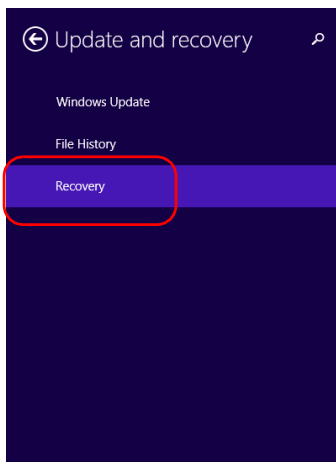

Refresh your PC without affecting your files

If your PC isn't running well, you can refresh it without losing your photos, music, videos, or other personal files.

[Get started](#)

Remove everything and reinstall Windows

If you want to recycle your PC or start over completely, you can reset it to its factory settings.

[Get started](#)

Advanced startup

Start up from a device or disc (such as a USB drive or DVD), change your PC's firmware settings, change Windows startup settings, or restore Windows from a system image. This will restart your PC.

[Restart now](#)

FTB-2

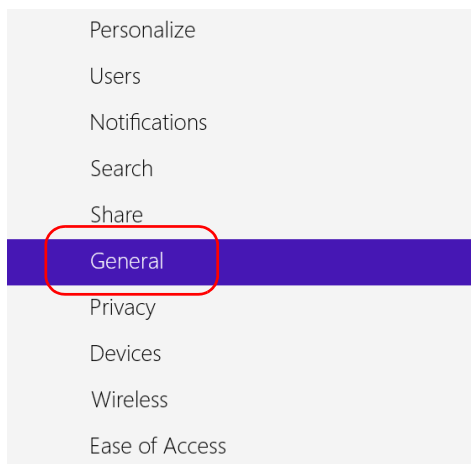

Refresh your PC without affecting your files

If your PC isn't running well, you can refresh it without losing your photos, music, videos, and other personal files.

[Get started](#)

Remove everything and reinstall Windows

If you want to recycle your PC or start over completely, you can reset it to its factory settings.

[Get started](#)

Advanced startup

Start up from a device or disc (such as a USB drive or DVD), change your PC's firmware settings, change Windows startup settings, or restore Windows from a system image. This will restart your PC.

[Restart now](#)

Troubleshooting

Restoring Your Unit to Normal Operation

- 8.** If you want to refresh or reset your unit, proceed as follows:
 - 8a.** Tap the **Get started** button corresponding to your choice.

The screenshot shows the Windows recovery environment. A red rounded rectangle highlights two options: 'Refresh your PC without affecting your files' and 'Remove everything and reinstall Windows'. Each option has a 'Get started' button. A line from the text 'To refresh your unit' points to the 'Get started' button for the refresh option. Another line from 'To reset your unit' points to the 'Get started' button for the reinstall option. Below the highlighted area, the 'Advanced startup' option is visible with a 'Restart now' button.

To refresh your unit — **Get started**

To reset your unit — **Get started**

Refresh your PC without affecting your files

If your PC isn't running well, you can refresh it without losing your photos, music, videos, and other personal files.

Remove everything and reinstall Windows

If you want to recycle your PC or start over completely, you can reset it to its factory settings.

Advanced startup

Start up from a device or disc (such as a USB drive or DVD), change your PC's firmware settings, change Windows startup settings, or restore Windows from a system image. This will restart your PC.

Restart now

- 8b.** Follow the on-screen instructions.

9. If you want to restore your unit (with a WIM file), proceed as follows:

9a. Under **Advanced Startup**, tap **Restart now**.

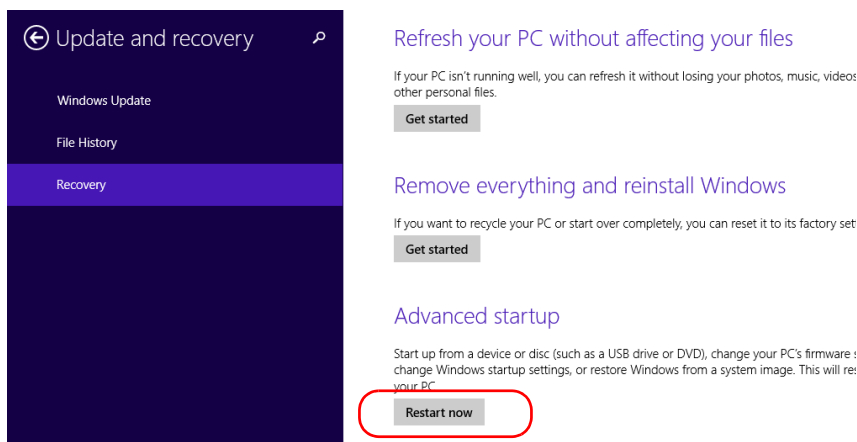

9b. Under **Choose an option**, tap **Troubleshoot**.

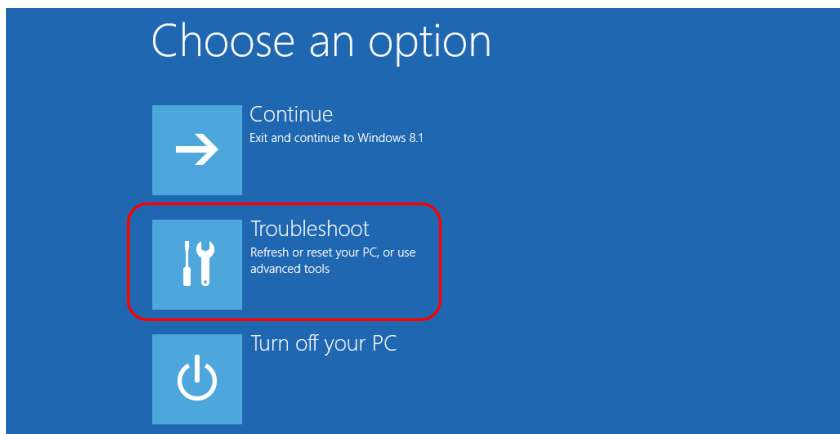

Troubleshooting

Restoring Your Unit to Normal Operation

- 9c.** Tap **Platform Imaging Utility** to display the corresponding application.

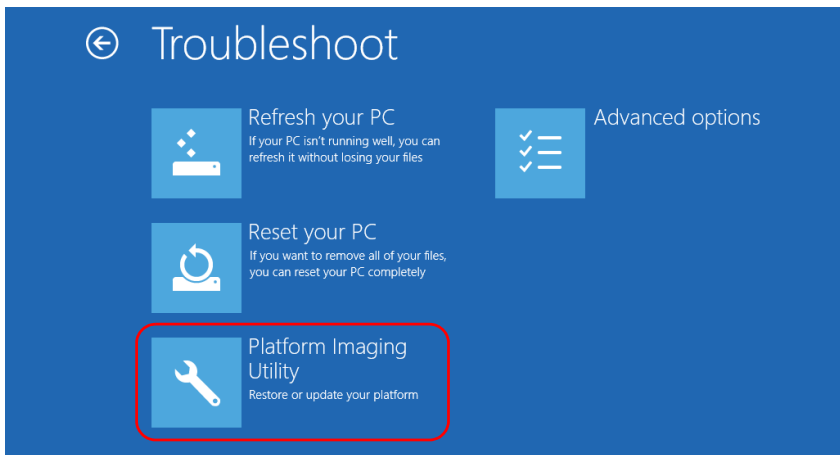

- 9d.** Connect the USB key with the desired WIM file to your unit.

- 9e.** From the Platform Servicing and Imaging Utility wizard, select **Restore unit from a WIM file**, and then tap **Next**.

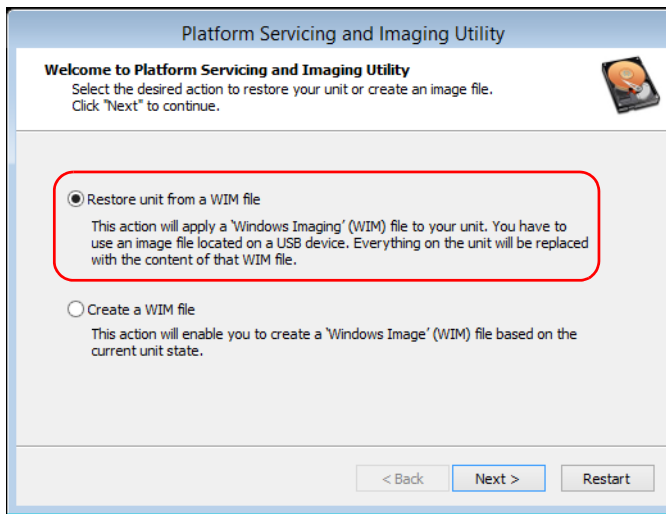

- 9f.** Tap **Browse**.

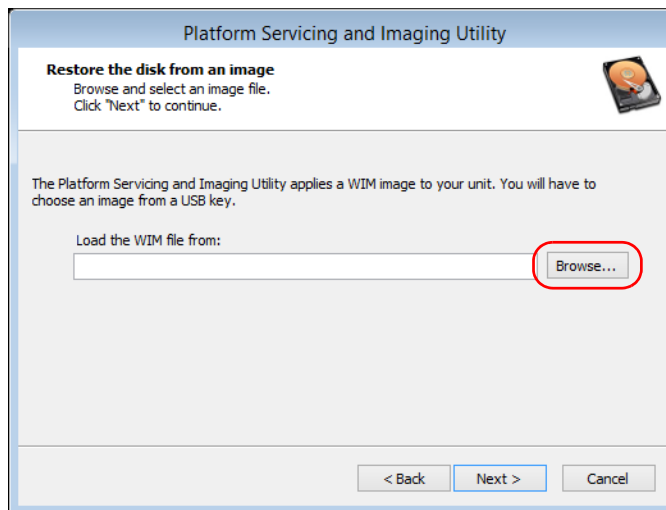

Troubleshooting

Restoring Your Unit to Normal Operation

- 9g.** Locate the USB key, and then double-tap its identifier to access the contents.
- 9h.** Select the desired WIM file.
- 9i.** Tap **Next**.

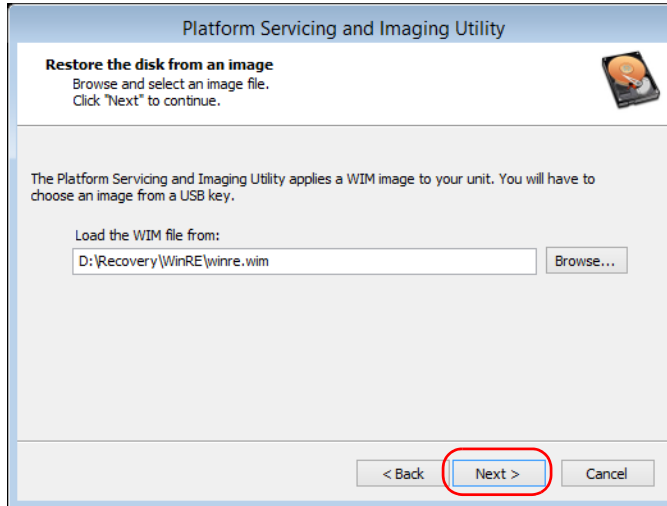

- 9j.** Read the warning, and then tap **Start** to restore the unit with the selected image.
- 9k.** When the operation is complete and the application prompts you, disconnect the USB key, and then tap **OK**.

The unit will restart.



IMPORTANT

The creation of a WIM file implies a compression of the files that are currently installed on your unit. The size of the files after compression cannot be estimated beforehand.

For this reason, the application **WILL NOT PROMPT YOU AT THE BEGINNING** of the operation if the storage capacity (or the file system) of your USB key is not appropriate.

To avoid problems, always use a USB key with an NTFS file system, and a minimum of 16 GB of free disk space.

To create a WIM file for your unit:

1. On your unit, from the right side of the screen, swipe left to display the Charm bar.
2. Tap **Settings > Change PC settings**.

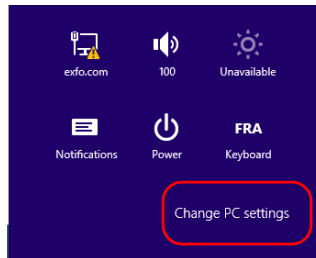

Troubleshooting

Restoring Your Unit to Normal Operation

3. On an FTB-2 Pro, tap **Update and recovery**.

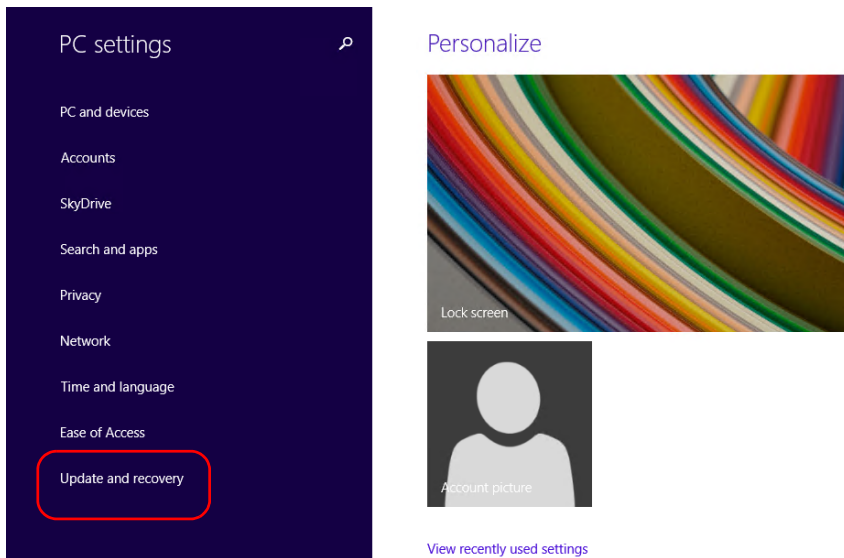

4. On an FTB-2 Pro, tap **Recovery**.
On an FTB-2, tap **General**, and then scroll down the list.

FTB-2 Pro

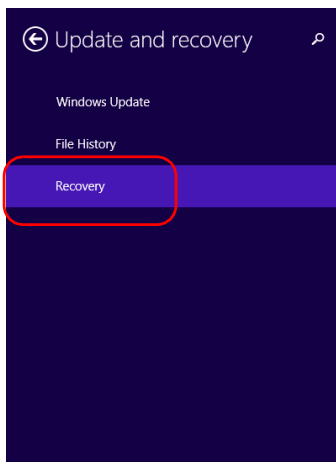

Refresh your PC without affecting your files

If your PC isn't running well, you can refresh it without losing your photos, music, videos, or other personal files.

[Get started](#)

Remove everything and reinstall Windows

If you want to recycle your PC or start over completely, you can reset it to its factory settings.

[Get started](#)

Advanced startup

Start up from a device or disc (such as a USB drive or DVD), change your PC's firmware settings, change Windows startup settings, or restore Windows from a system image. This will restart your PC.

[Restart now](#)

FTB-2

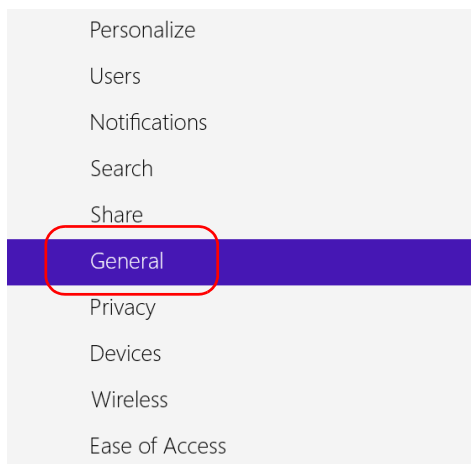

Refresh your PC without affecting your files

If your PC isn't running well, you can refresh it without losing your photos, music, videos, and other personal files.

[Get started](#)

Remove everything and reinstall Windows

If you want to recycle your PC or start over completely, you can reset it to its factory settings.

[Get started](#)

Advanced startup

Start up from a device or disc (such as a USB drive or DVD), change your PC's firmware settings, change Windows startup settings, or restore Windows from a system image. This will restart your PC.

[Restart now](#)

Troubleshooting

Restoring Your Unit to Normal Operation

5. Under **Advanced Startup**, tap **Restart now**.

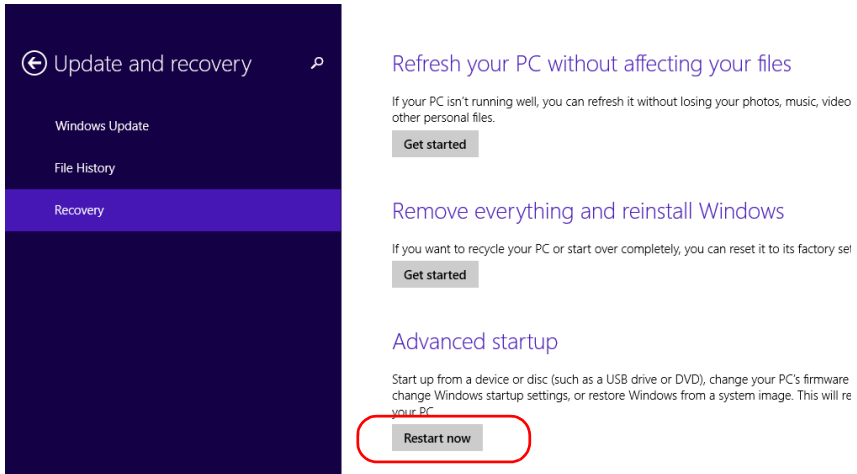

6. Under **Choose an option**, tap **Troubleshoot**.

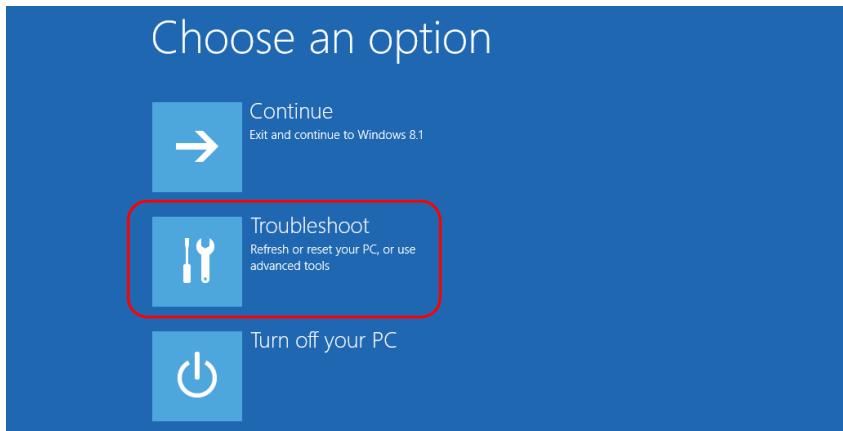

7. Tap **Platform Imaging Utility** to display the corresponding application.

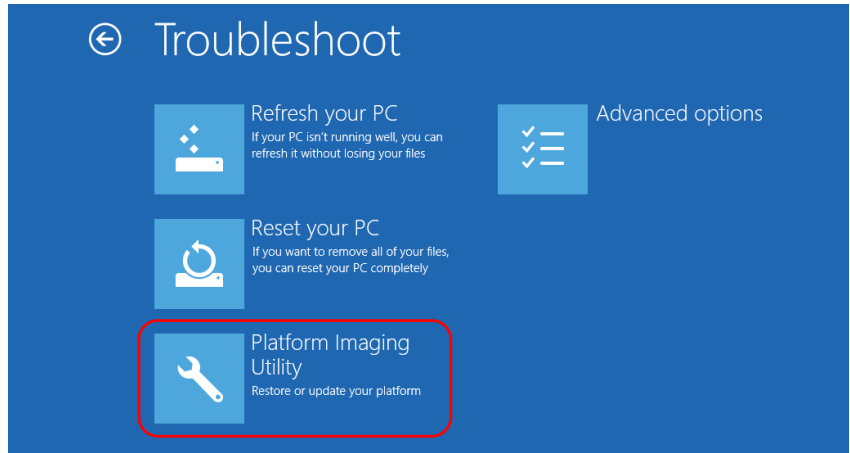

8. Connect a USB key to your unit.
9. From the Platform Servicing and Imaging Utility wizard, select **Create a WIM file**, and then tap **Next**.

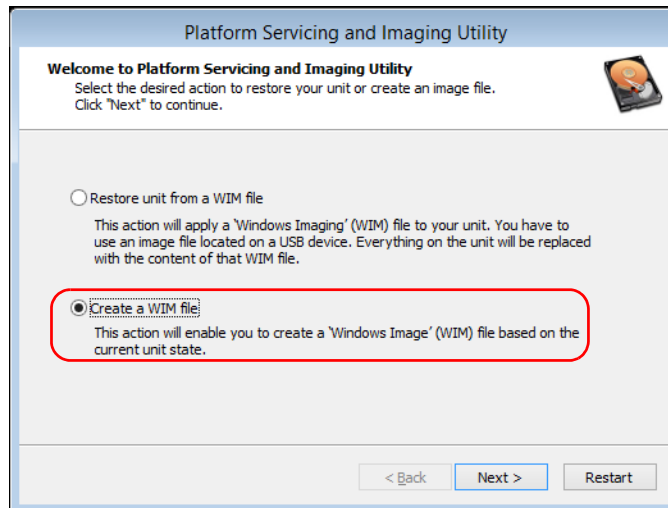

Troubleshooting

Restoring Your Unit to Normal Operation

10. Tap **Browse.**

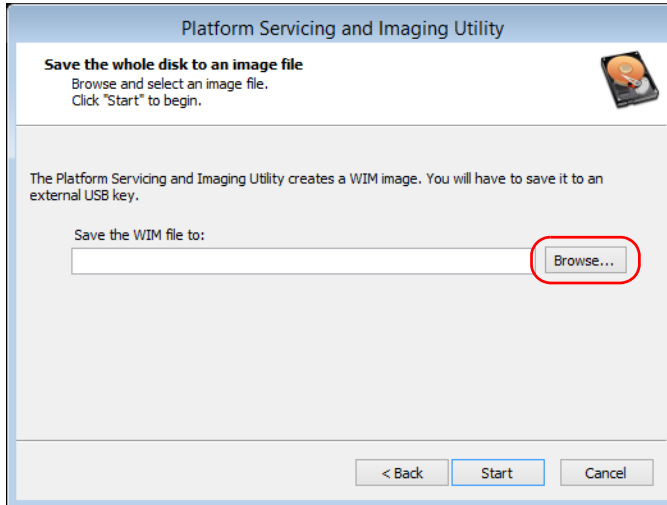

11. Locate the USB key, and then double-tap its identifier to access the contents.

12. Select the desired folder.

13. Enter a file name, and then tap **Save**.

14. Tap **Start**.

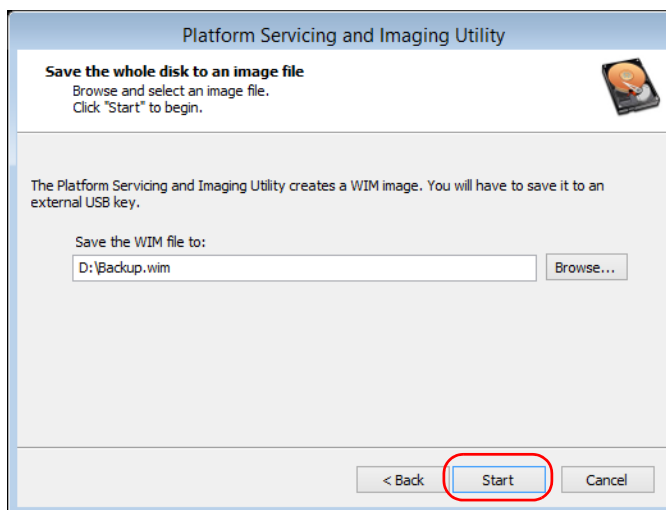

Note: *The time required to create the image varies with the configuration of your unit.*

15. When the operation is complete and the application prompts you, tap **OK**.

16. Disconnect the USB key.

Troubleshooting

Restoring Your Unit to Normal Operation

17. Tap **Cancel** to return to the Welcome window of the utility.

18. Tap **Restart**.

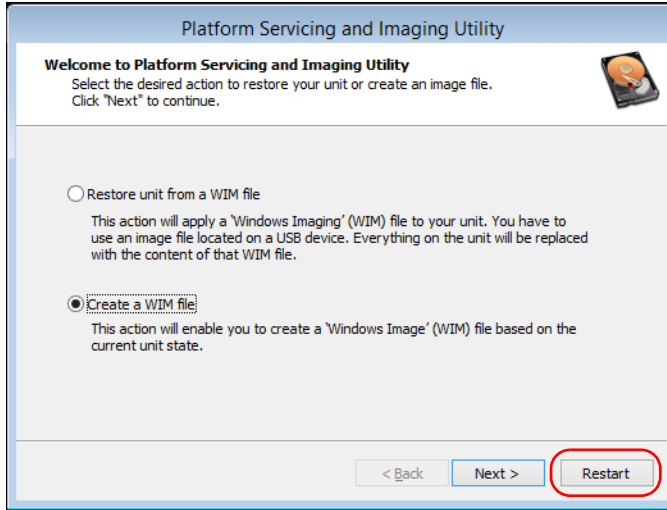

The WIM file is ready for future use.

Accessing the Online Documentation

You can access the user documentation as well as the license agreements at all times from your unit.

There are two formats of user documentation provided on your unit: online help and complete user guides (for products having safety instructions). When you open user documentation in PDF format from ToolBox X (or the configuration wizard), the files are displayed automatically in the provided PDF viewer.

Note: *The user guides of all products are available from the My EXFO section of the EXFO Web site (www.exfo.com) for download in PDF format.*

To view the online help:

From ToolBox X or an instrument application, tap  (or the equivalent).

To view the documentation in PDF format:

1. From the main window, tap the **Utilities** button.
2. Tap the icon corresponding to the type of document that you want to view.

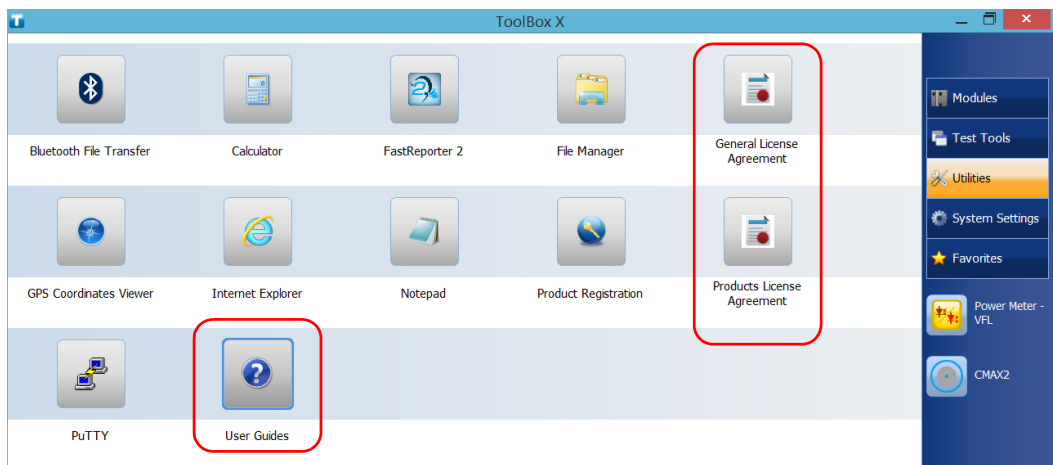

Troubleshooting

Contacting the Technical Support Group

Contacting the Technical Support Group

To obtain after-sales service or technical support for this product, contact EXFO at one of the following numbers. The Technical Support Group is available to take your calls from Monday to Friday, 8:00 a.m. to 7:00 p.m. (Eastern Time in North America).

Technical Support Group

400 Godin Avenue
Quebec (Quebec) G1M 2K2
CANADA

1 866 683-0155 (USA and Canada)
Tel.: 1 418 683-5498
Fax: 1 418 683-9224
support@exfo.com

For detailed information about technical support, and for a list of other worldwide locations, visit the EXFO Web site at www.exfo.com.

If you have comments or suggestions about this user documentation, you can send them to customer.feedback.manual@exfo.com.

To accelerate the process, please have information such as the name and the serial number (see the product identification label), as well as a description of your problem, close at hand.

Viewing System Information

You can easily access important information such as the serial number, version numbers for ToolBox X and hardware components, or network interfaces information directly from your unit. You can also find the contact information if you ever need to reach EXFO.

Retrieving the Serial Number of Your Unit

The serial number of your unit is easily accessible from ToolBox X.

Note: *You can also view the serial number on the label affixed to the back of your unit.*

To retrieve the serial number of your unit:

1. In the lower right corner of the main window, tap .
2. Tap the **Platform** tab.

The serial number is displayed.

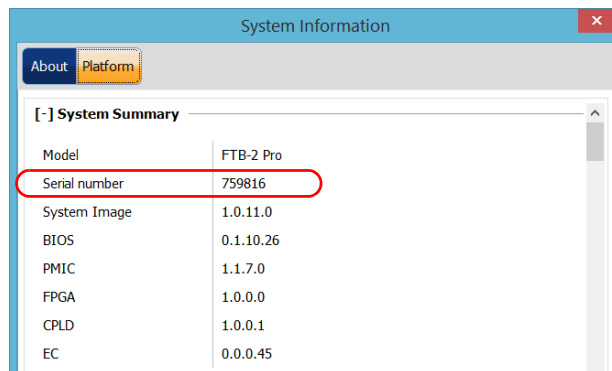

Note: *The serial numbers of your modules are visible from the **Modules** window.*

Troubleshooting

Viewing System Information

Retrieving the Component Versions

You can view the version of ToolBox X as well as those of the system image and hardware components that are installed on your unit.

To retrieve the ToolBox X version:

1. In the lower right corner of the main window, tap .
2. Tap the **About** tab.

The version number is displayed.



To retrieve the version numbers of the system image and hardware components:

1. In the lower right corner of the main window, tap .
2. Tap the **Platform** tab.

The version numbers are displayed.

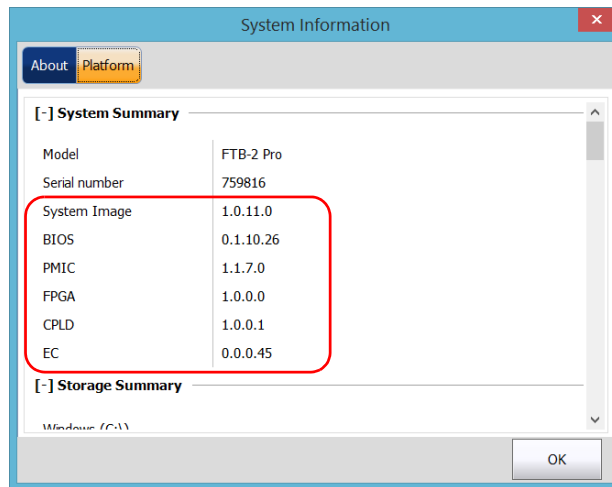

Retrieving Network Interfaces Information

You can view the information related to the network interfaces (adapters) such as the status of the interfaces, the IP address, etc.

To retrieve network interfaces information for Ethernet and Bluetooth:

1. In the lower right corner of the main window, tap .
2. Tap the **Platform** tab.

The information is displayed (one section per network interface).

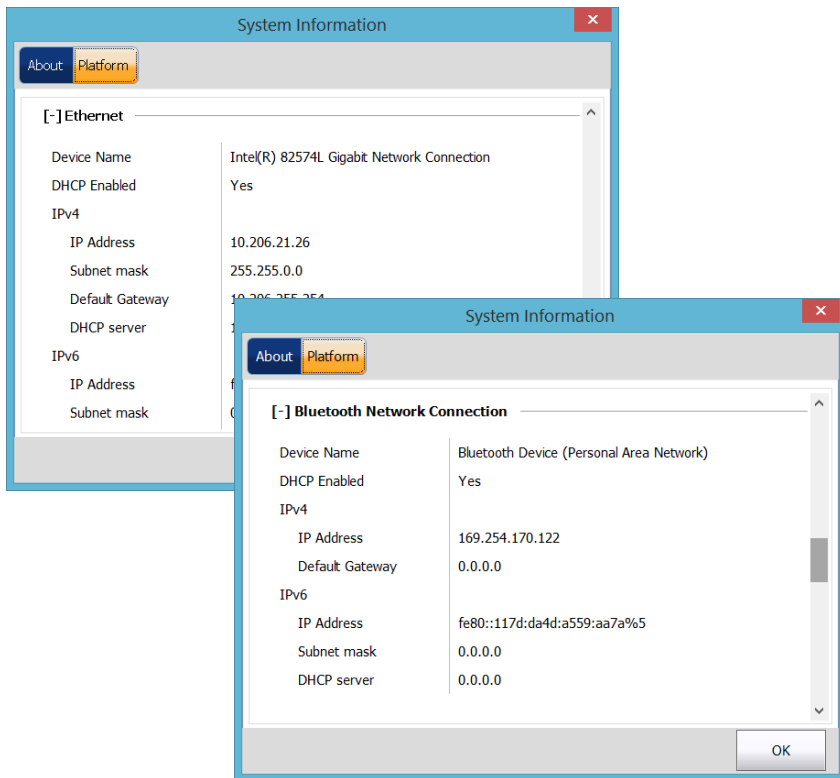

To retrieve network interfaces information for Wi-Fi:

1. From the main window, tap the **System Settings** button.
2. Tap **Control Panel**.



3. Under **Network and Internet**, tap **View network status and tasks**.

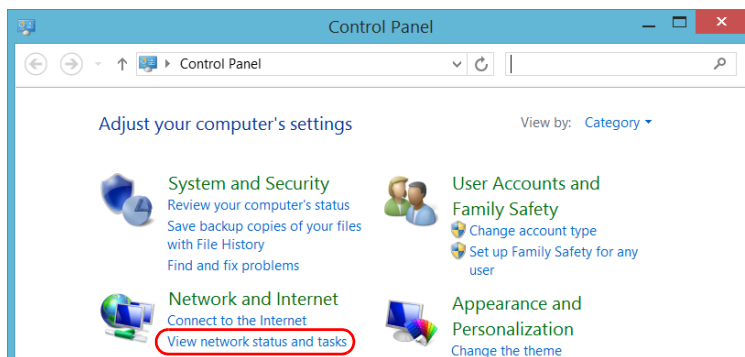

4. Tap the link corresponding to the Wi-Fi network.

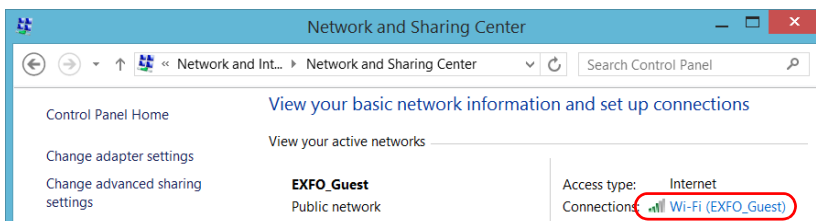

Troubleshooting

Retrieving Network Interfaces Information

- From the **Wi-Fi Status** window, tap **Details**.

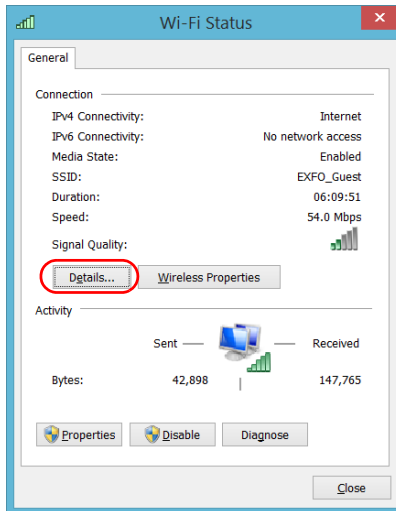

- When your work is done, close the window.

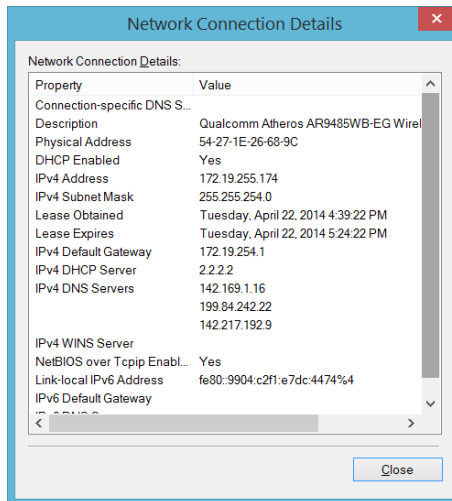

- Close all other windows to return to ToolBox X.

Retrieving the Contact Information

All the information necessary to contact EXFO is available from your unit.

To retrieve the contact information:

1. In the lower right corner of the main window, tap .
2. Tap the **About** tab.

The contact information is displayed.



Troubleshooting

Transportation

Transportation

Maintain a temperature range within specifications when transporting the unit. Transportation damage can occur from improper handling. The following steps are recommended to minimize the possibility of damage:

- Pack the unit in its original packing material when shipping.
- Avoid high humidity or large temperature fluctuations.
- Keep the unit out of direct sunlight.
- Avoid unnecessary shocks and vibrations.

15 Warranty

General Information

EXFO Inc. (EXFO) warrants this equipment against defects in material and workmanship for a period of one year from the date of original shipment. EXFO also warrants that this equipment will meet applicable specifications under normal use.

During the warranty period, EXFO will, at its discretion, repair, replace, or issue credit for any defective product, as well as verify and adjust the product free of charge should the equipment need to be repaired or if the original calibration is erroneous. If the equipment is sent back for verification of calibration during the warranty period and found to meet all published specifications, EXFO will charge standard calibration fees.



IMPORTANT

The warranty can become null and void if:

- unit has been tampered with, repaired, or worked upon by unauthorized individuals or non-EXFO personnel.
- warranty sticker has been removed.
- case screws, other than those specified in this guide, have been removed.
- case has been opened, other than as explained in this guide.
- unit serial number has been altered, erased, or removed.
- unit has been misused, neglected, or damaged by accident.

THIS WARRANTY IS IN LIEU OF ALL OTHER WARRANTIES EXPRESSED, IMPLIED, OR STATUTORY, INCLUDING, BUT NOT LIMITED TO, THE IMPLIED WARRANTIES OF MERCHANTABILITY AND FITNESS FOR A PARTICULAR PURPOSE. IN NO EVENT SHALL EXFO BE LIABLE FOR SPECIAL, INCIDENTAL, OR CONSEQUENTIAL DAMAGES.

Warranty

Liability

Liability

EXFO shall not be liable for damages resulting from the use of the product, nor shall be responsible for any failure in the performance of other items to which the product is connected or the operation of any system of which the product may be a part.

EXFO shall not be liable for damages resulting from improper usage or unauthorized modification of the product, its accompanying accessories and software.

Exclusions

EXFO reserves the right to make changes in the design or construction of any of its products at any time without incurring obligation to make any changes whatsoever on units purchased. Accessories, including but not limited to fuses, pilot lamps, batteries and universal interfaces (EUI) used with EXFO products are not covered by this warranty.

This warranty excludes failure resulting from: improper use or installation, normal wear and tear, accident, abuse, neglect, fire, water, lightning or other acts of nature, causes external to the product or other factors beyond the control of EXFO.



IMPORTANT

In the case of products equipped with optical connectors, EXFO will charge a fee for replacing connectors that were damaged due to misuse or bad cleaning.

Certification

EXFO certifies that this equipment met its published specifications at the time of shipment from the factory.

Service and Repairs

EXFO commits to providing product service and repair for five years following the date of purchase.

To send any equipment for service or repair:

- 1.** Call one of EXFO's authorized service centers (see *EXFO Service Centers Worldwide* on page 326). Support personnel will determine if the equipment requires service, repair, or calibration.
- 2.** If equipment must be returned to EXFO or an authorized service center, support personnel will issue a Return Merchandise Authorization (RMA) number and provide an address for return.
- 3.** If possible, back up your data before sending the unit for repair.
- 4.** Pack the equipment in its original shipping material. Be sure to include a statement or report fully detailing the defect and the conditions under which it was observed.
- 5.** Return the equipment, prepaid, to the address given to you by support personnel. Be sure to write the RMA number on the shipping slip. *EXFO will refuse and return any package that does not bear an RMA number.*

Note: *A test setup fee will apply to any returned unit that, after test, is found to meet the applicable specifications.*

After repair, the equipment will be returned with a repair report. If the equipment is not under warranty, you will be invoiced for the cost appearing on this report. EXFO will pay return-to-customer shipping costs for equipment under warranty. Shipping insurance is at your expense.

Routine recalibration is not included in any of the warranty plans. Since calibrations/verifications are not covered by the basic or extended warranties, you may elect to purchase FlexCare Calibration/Verification Packages for a definite period of time. Contact an authorized service center (see *EXFO Service Centers Worldwide* on page 326).

Warranty

EXFO Service Centers Worldwide

EXFO Service Centers Worldwide

If your product requires servicing, contact your nearest authorized service center.

EXFO Headquarters Service Center

400 Godin Avenue
Quebec (Quebec) G1M 2K2
CANADA

1 866 683-0155 (USA and Canada)
Tel.: 1 418 683-5498
Fax: 1 418 683-9224
support@exfo.com

EXFO Europe Service Center

Winchester House, School Lane
Chandlers Ford, Hampshire S053 4DG
ENGLAND

Tel.: +44 2380 246800
Fax: +44 2380 246801
support.europe@exfo.com

EXFO Telecom Equipment (Shenzhen) Ltd.

3rd Floor, Building C,
FuNing Hi-Tech Industrial Park, No. 71-3,
Xintian Avenue,
Fuyong, Bao'An District,
Shenzhen, China, 518103

Tel: +86 (755) 2955 3100
Fax: +86 (755) 2955 3101
support.asia@exfo.com

To view EXFO's network of partner-operated Certified Service Centers nearest you, please consult EXFO's corporate website for the complete list of service partners:

<http://www.exfo.com/support/services/instrument-services/exfo-service-centers>.

A *Technical Specifications*



IMPORTANT

The following technical specifications can change without notice. The information presented in this section is provided as a reference only. To obtain this product's most recent technical specifications, visit the EXFO Web site at www.exfo.com.

TECHNICAL SPECIFICATIONS *	FTB-2	FTB-2 Pro
Display	Touchscreen, color, 1280 x 800 TFT 256 mm (10.1 in)	Touchscreen, color, 1280 x 800 TFT 256 mm (10.1 in)
Interfaces	RJ-45 LAN 10/100/1000 Mbit/s Two USB 2.0 ports One USB 3.0 port Display port Headset jack	RJ-45 LAN 10/100/1000 Mbit/s Two USB 2.0 ports One USB 3.0 port Display port Headset jack
Storage	64 GB internal memory (flash)	64 GB or 128 GB internal memory (flash)
Battery	One rechargeable Li-ion smart battery	Two rechargeable Li-ion smart batteries
Power supply	AC/DC adapter, input: ~ 100 – 240 V; 50/60 Hz; 2.5 A max, output: ~ 24 V; 3.75 A	AC/DC adapter, input: ~ 100 – 240 V; 50/60 Hz; 4.0 A max, output: ~ 24 V; 8.33 A
Computer	Dual-core processor / 4 GB RAM / Windows Embedded 8 Standard	Quad-core processor / 4 GB RAM / Windows 8.1 Pro

* Highest size available as a hardware option

GENERAL SPECIFICATIONS	
Size (H x W x D)	199 mm x 333 mm x 119 mm (7 ¹³ / ₁₆ in x 13 ¹ / ₈ in x 4 ¹¹ / ₁₆ in)
Weight ^c	3 kg (6.6 lb)
Temperature Operation Storage ^b	0 °C to 50 °C (32 °F to 122 °F) -40 °C to 60 °C (-40 °F to 140 °F)
Relative humidity	≤95 % noncondensing

Technical Specifications

BUILT-IN POWER METER SPECIFICATIONS (GeX) (OPTIONAL) ^d

Calibrated wavelengths (nm)	850, 1300, 1310, 1490, 1550, 1625, 1650
Optional CWDM calibrated wavelengths (nm)	1270, 1290, 1310, 1330, 1350, 1370, 1390, 1410, 1430, 1450, 1470, 1490, 1510, 1530, 1550, 1570, 1590, 1610, 1383, 1625
Power range (dBm) ^e	27 to -50
Uncertainty (%) ^{e,f}	±5 % ± 10 nW
Display resolution (dB)	0.01 = max to -40 dBm 0.1 = -40 dBm to -50 dBm

VISUAL FAULT LOCATOR (VFL) (OPTIONAL)

Laser, 650 nm ± 10 nm

CW/Modulate 1 Hz

Typical P_{out} in 62.5/125 μm: >-1.5 dBm (0.7 mW)

Notes

- All specifications valid at 23 °C (73 °F).
- Not including internal batteries. Battery storage temperatures: -20 °C to 60 °C (-4 °F to 140 °F) for shipping, and -20 °C to 45 °C (-4 °F to 113 °F) for long-term storage.
- Platform without batteries or modules
- At 23 °C ± 1 °C, 1550 nm and FC connector. With modules in idle mode. Battery operated after warm-up.
- Typical.
- At calibration conditions.

B Data Types

The following section provides an overview of the most common data types that may appear in EXFO's documentation on commands and queries. The information is supplied for guidance only.

For more detailed information, please refer to IEEE 488.2 and SCPI standards.

Data types are divided into two groups: <PROGRAM DATA> for the types that are used when you want to send messages to a device and <RESPONSE DATA> for the types that are used when a device sends responses to the controller.

The data types are presented in graphics often referred to as "railroad diagrams". The following example illustrates how to interpret such diagrams.

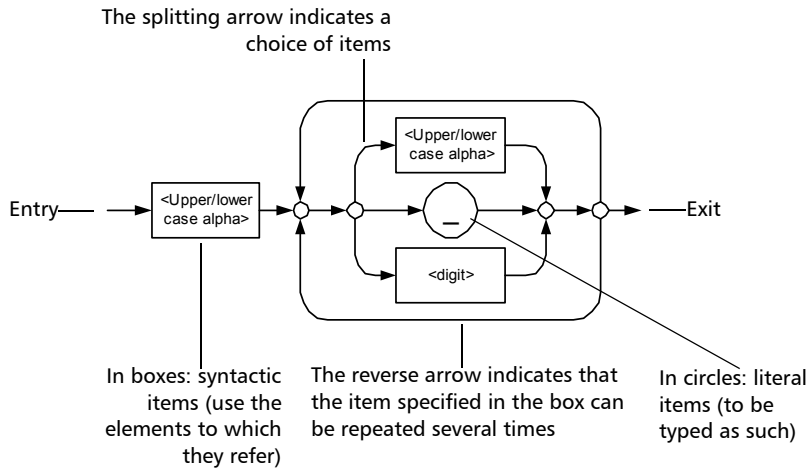

Data Types

Applicable Data Types for Input—IEEE 488.2

Applicable Data Types for Input—IEEE 488.2

- <PROGRAM MESSAGE TERMINATOR>

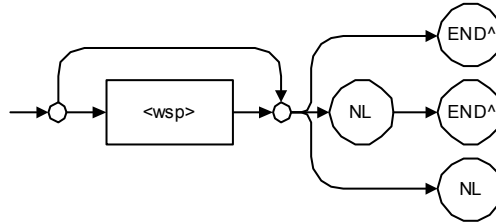

In the diagram above,

- “NL” corresponds to ASCII character code 10, in decimal (0A in binary)
- “END ^” corresponds to the last data byte of the message sent with EOI = True and ATN = False

➤ **<CHARACTER PROGRAM DATA>**

This data type will be used to send short mnemonics when a *<DECIMAL NUMERIC PROGRAM DATA>* cannot be used.

Examples: TRIANGLEWAVE, NCONTINUOUS

➤ **<DECIMAL NUMERIC PROGRAM DATA>** (or **<NRf>**)

This data type includes **<NR1>**, **<NR2>** and **<NR3>** data types. It will be used for decimal fractions with or without an exponent. Instruments will adapt the values they receive to fit their degree of precision. For example, if an instrument has a precision of two digits after the decimal point and the incoming value is 12.048, this value will be rounded off to 12.05.

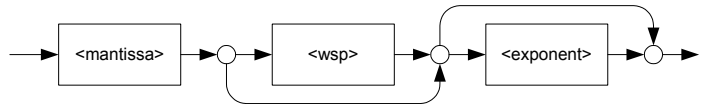

The second diagram below illustrates the **<mantissa>** syntax.

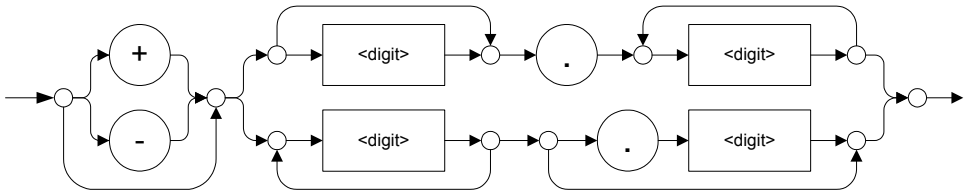

The third diagram illustrates the **<exponent>** syntax.

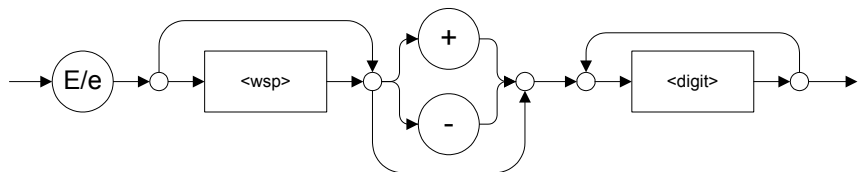

Examples: +2.0 e5, -.56E+4, 6.5e-10

Data Types

Applicable Data Types for Input—IEEE 488.2

➤ <NON-DECIMAL NUMERIC PROGRAM DATA>

This data type will be used for integer representation in hexadecimal (base 16), octal (base 8) or binary (base 2). The numeric representations will begin with “#H” for hexadecimal, “#Q” for octal and “#B” for binary.

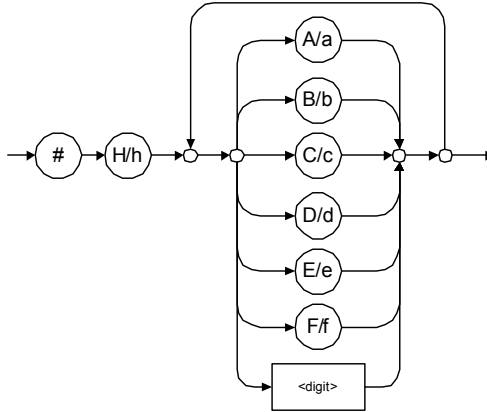

Examples: #Hf3bc015d, #h01a4, #hfe

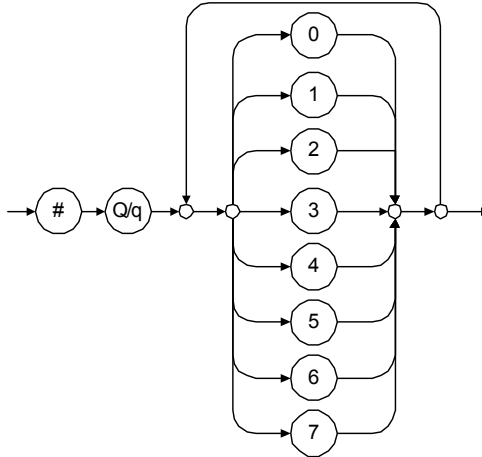

Examples: #Q1234567, #q1275, #q07

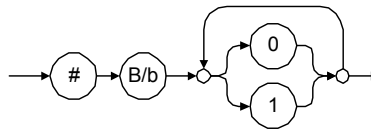

Examples: #B10010111, #b10110, #b1100

Data Types

Applicable Data Types for Input—IEEE 488.2

➤ <STRING PROGRAM DATA>

This data type will be used for strings containing 7-bit ASCII characters that have to be enclosed in either single- or double-quotes delimiters.

If a string needs to contain a character that is exactly the same as the delimiter, make sure to double the character to avoid syntax errors.

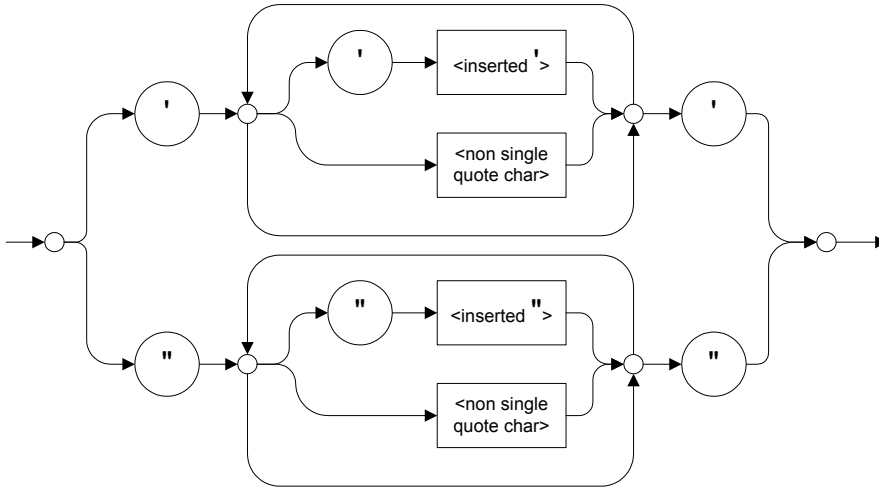

Examples: "SCPI Commands", 'SCPI Commands', "SCPI 'Commands'",
'SCPI "Commands"', "SCPI ""Commands""", 'SCPI ""Commands""'

➤ <ARBITRARY BLOCK PROGRAM DATA>

This data type is used to send blocks of arbitrary 8-bit information when you need to work with large amounts of data.

The actual length of the data that you send has the following structure:

- The first byte contains the # character.
- The byte that immediately follows contains the number of subsequent bytes that you have to check to obtain the total length.

Note: *If you use a zero as the first digit (#0), it has to be followed by a <PROGRAM MESSAGE TERMINATOR > so that the device will detect the end of the <ARBITRARY BLOCK PROGRAM DATA>. This will also force immediate termination of the message.*

For example, if you send the following data (here, values are expressed in decimal instead of binary for easier readability):

2 1 3 7 6 8 9 2 ...

The byte that immediately follows the # contains 2, which means that you would have to read the two following bytes to know the length (in bytes) of the retrieved data. The bytes indicate 1 and 3. The length will then be 13 bytes. The actual response will begin at byte number 5, in this case.

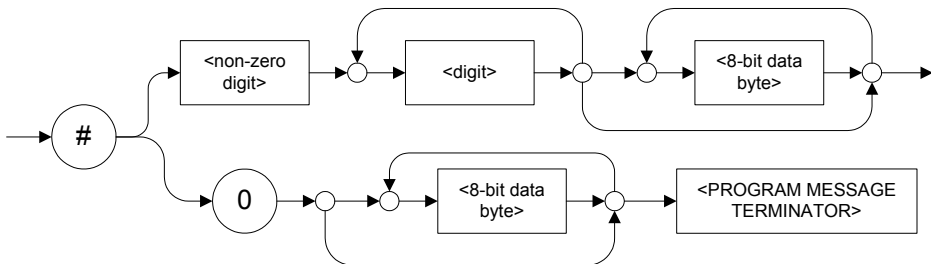

Data Types

Applicable Data Types for Input—IEEE 488.2

► <SUFFIX PROGRAM DATA>

This data type is used when units and multipliers have to be sent.

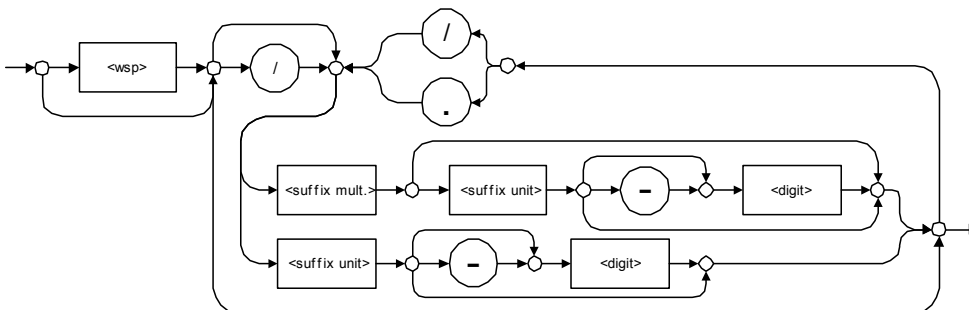

Examples: nm, kHz, km/s², uW

A relative unit (dB) can be referenced to an absolute level, as shown on the following diagram.

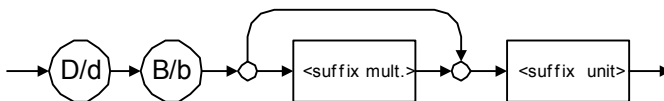

Examples: db, dbm, dBW

The following table illustrates the possible forms for <suffix mult.>:

Name	Value	Mnemonic
Exa	1E18	EX
Peta	1E15	PE
Tera	1E12	T
Giga	1E9	G
Mega	1E6	MA
Kilo	1E3	K
Milli	1E-3	M
Micro	1E-6	U
Nano	1E-9	N
Pico	1E-12	P
Femto	1E-15	F
Atto	1E-18	A

Data Types

Applicable Data Types for Input—IEEE 488.2

The table below gives the possible forms for <suffix unit> :

Reference Unit	Suffix Unit
Degrees	DEG
Radians	RAD
Amperes	A
Volts	V
Hertz	HZ
Meters	M
Watts	W
DBs ref to 1mW	DBM
Decibels	DB
Degrees Celsius	CEL
Degrees Fahrenheit	FAR
Kelvins	K
Seconds	S
Hours	HR
Minutes	MIN

Applicable Data Types for Output —IEEE 488.2

- <RESPONSE MESSAGE TERMINATOR>

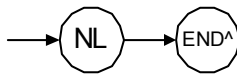

In the diagram above,

- “NL” corresponds to ASCII character code 10, in decimal (0A in binary)
- “END ^” corresponds to the last data byte of the message sent with EOI = True and ATN = False
- <CHARACTER RESPONSE DATA>

This data type will be used by a device to return short mnemonics when a <*DECIMAL NUMERIC PROGRAM DATA*> cannot be used. The returned information is sent in the long form and in upper case.

Examples: TRIANGLEWAVE, NCONTINUOUS

Data Types

Applicable Data Types for Output —IEEE 488.2

- <NR1 NUMERIC RESPONSE DATA> (or <NR1>)

This data type will be used by a device to return positive or negative integers.

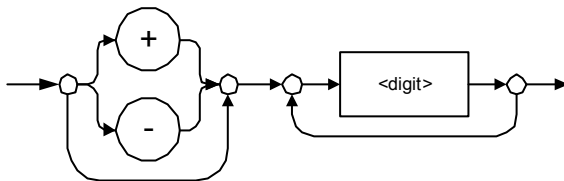

Examples: 4, -23, 90

- <NR2 NUMERIC RESPONSE DATA> (or <NR2>)

This data type will be used by a device to return positive or negative real numbers (fixed-point numbers).

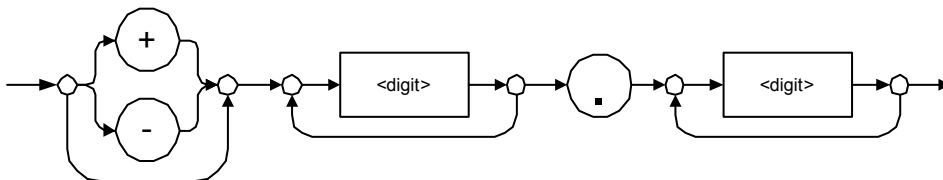

Examples: 23.45, 1.22, -4.55

➤ **<NR3 NUMERIC RESPONSE DATA> (or <NR3>)**

This data type will be used by a device to return positive or negative exponential numbers (floating-point numbers).

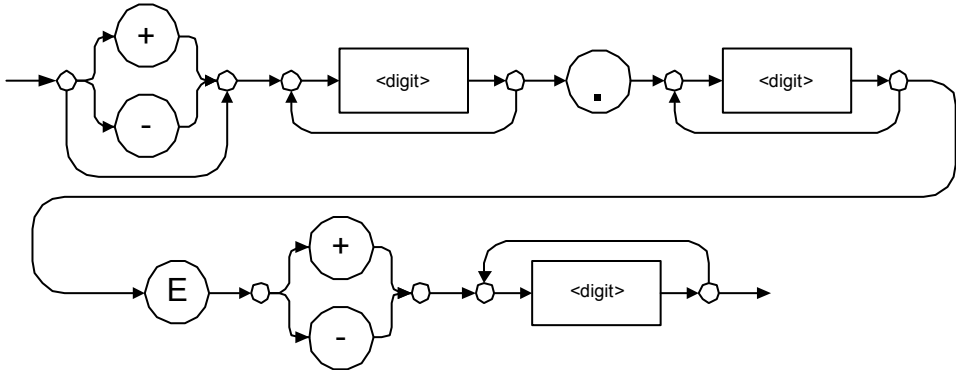

Examples: 4.3E-3, -8.9456E8, 123E-5

Data Types

Applicable Data Types for Output —IEEE 488.2

➤ **Special Numeric Values Received on Output**

In some cases, an instrument may send values indicating that an unusual event has occurred. The following tables present the possible values.

Value is	ASCII 4 bytes	PACKED 4 bytes
Under range	2143289345.000000	7FC00001
Over range	2143289346.000000	7FC00002
Invalid	2143289347.000000	7FC00003
Inactive	2143289348.000000	7FC00004

Value is	ASCII 8 bytes	PACKED 8 bytes
Under range	9221120237577961472	7FF8000020000000
Over range	9221120238114832384	7FF8000040000000
Invalid	9221120238651703296	7FF8000060000000
Inactive	9221120239188574208	7FF8000080000000

➤ <HEXADECIMAL NUMERIC RESPONSE DATA>

This data type will be used by a device to return integer representations in hexadecimal (base 16).

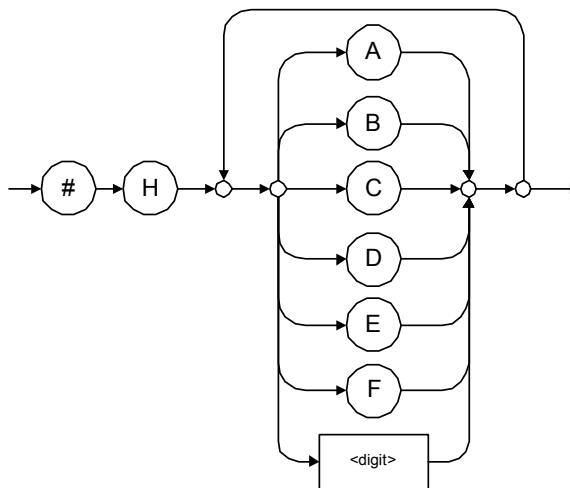

Examples: #HA3C5, #H0123C, #H010F

Data Types

Applicable Data Types for Output —IEEE 488.2

➤ <OCTAL NUMERIC RESPONSE DATA>

This data type will be used by a device to return integer representations in octal (base 8).

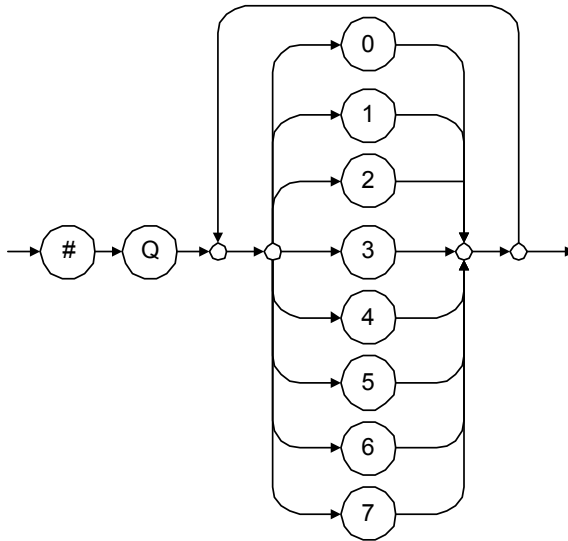

Examples: #Q753214, #Q0124, #Q0725

➤ **<BINARY NUMERIC RESPONSE DATA>**

This data type will be used by a device to return integer representations in binary (base 2).

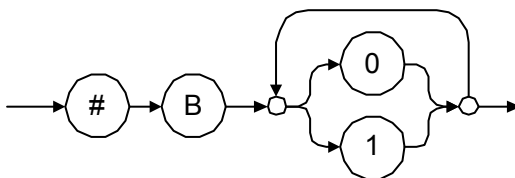

Examples: #B11011110101, #B110100, #B0100

➤ **<STRING RESPONSE DATA>**

This data type will be used by a device to return strings containing 7-bit ASCII characters and especially when text has to be displayed since even the non-printable characters are also returned.

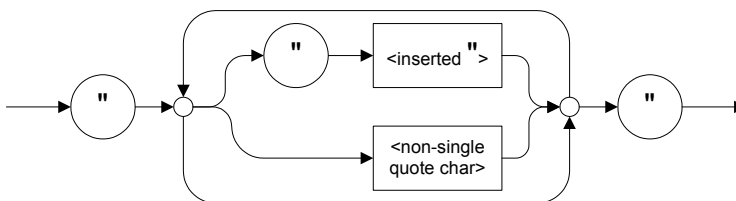

Examples: "SCPI Commands", "SCPI ""Commands""

Data Types

Applicable Data Types for Output —IEEE 488.2

➤ <DEFINITE LENGTH ARBITRARY BLOCK RESPONSE DATA>

This data type is used by a device to return blocks of 8-bit binary information with a fixed and predetermined length.

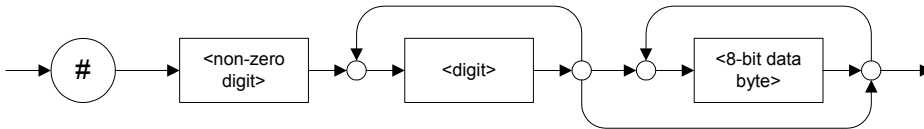

The actual length of the retrieved data has the following structure:

- The first byte contains the # character.
- The byte that immediately follows contains the number of subsequent bytes that you have to check to know the total length.

For example, if you receive this response (here, values are expressed in decimal instead of binary for easier readability):

2 1 3 7 6 8 9 2 ...

The byte that immediately follows the # contains 2, which means that you have to read the two following bytes to know the length (in bytes) of the retrieved data. The bytes indicate 1 and 3. The length will then be 13 bytes. The actual response will begin at byte number 5, in this case.

Examples: #14<DAB> <DAB> <DAB> <DAB> ,
#3004<DAB> <DAB> <DAB> <DAB>

where “<DAB>” stands for data byte

➤ <INDEFINITE LENGTH ARBITRARY BLOCK RESPONSE DATA>

This data type is used by a device to return blocks of 8-bit binary information when the block length was not predefined or when data has to be computed later.

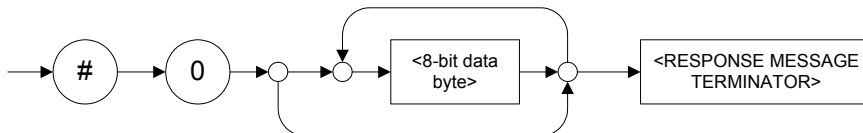

Note: *If you receive a zero as the first digit (#0), it is necessarily followed by a <RESPONSE PROGRAM MESSAGE TERMINATOR> so that you will detect the end of the <INDEFINITE LENGTH ARBITRARY BLOCK RESPONSE DATA>.*

Example: #0<DAB><DAB><DAB><DAB><terminator> where “<DAB>” stands for data byte.

Data Types

Applicable Data Types for Output —IEEE 488.2

➤ <SUFFIX RESPONSE DATA>

This data type is used by a device to return units and multipliers.

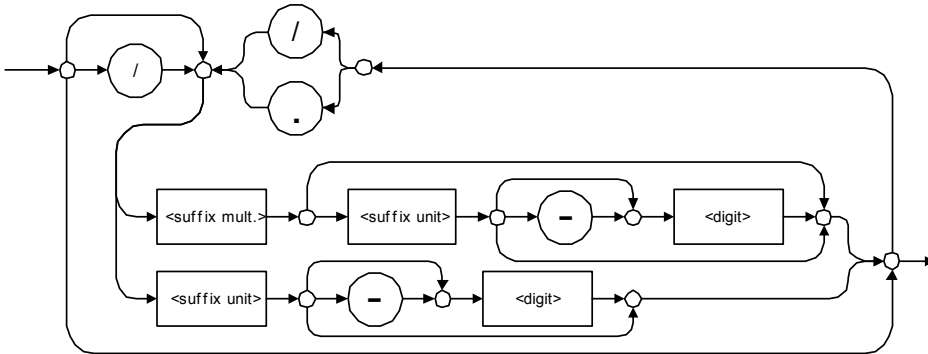

Examples: DBW, W, KHZ

➤ <ARBITRARY ASCII RESPONSE DATA>

This data type is used by a device to return information when it is impossible to use any other data type.

Example: To the *IDN? query, the device will return this response in an arbitrary ASCII bytes format:

EXFO E.O. Engineering,,125-2A55,1.0.1.97

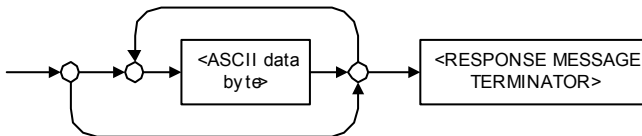

Applicable Data Types for Input—SCPI

SCPI data types include the IEEE 488.2 data types (see *Applicable Data Types for Input—IEEE 488.2* on page 330) with certain additional restrictions.

- `<numeric_value>`: abbreviated form of the decimal numeric element. It differs from the `<DECIMAL NUMERIC PROGRAM DATA>` “`<NRf>`” described in IEEE 488.2.

Several forms of `<CHARACTER PROGRAM DATA>` are defined as special forms of numbers. These are: MINimum, MAXimum, DEFault, UP, DOWN, Not A Number (NAN), INFinity and Negative INFinity (NINF). The following special forms are likely to be used by EXFO’s instruments in certain commands or queries:

- DEFault: This special `<numeric_value>` parameter forces the instrument to select a value, which is deemed to be convenient to the user.
- MINimum|MAXimum: These special `<numeric_value>` parameters refer to the instrument’s limit values. MINimum corresponds to the value closest to negative infinity that the function can accept. MAXimum corresponds to the largest value that the function can accept.
- `<Boolean Program Data>`: This form is often used as a shorthand of the `<DECIMAL NUMERIC PROGRAM DATA>`ON|OFF form.

`<Boolean Program Data>` parameters have a value of 0 or 1 and are not followed by any unit.

On input, an `<NRf>` is rounded to an integer.

A non-zero result is interpreted as 1.

ON and OFF are accepted on input for readability purposes. They correspond respectively to 1 and 0. However, on output, they appear as 1 or 0, never ON or OFF.

Data Types

Special Numeric Values Received on Output

Special Numeric Values Received on Output

It is possible that an instrument returns unusual values in certain cases. For information on these values, see Applicable Data Types for Output —IEEE 488.2 *on page 339*.

C **IEEE 488.2 and Specific Command Reference**

This chapter presents detailed information about the commands and queries supplied with your FTB-2 and FTB-2 Pro.

IEEE 488.2 Commands–Quick Reference

The FTB-2 and FTB-2 Pro recognizes the required commands identified in IEEE 488.2. The table below summarizes these commands. These commands are fully explained on the following pages.

Command	Function
*CLS	Clear status command
*ESE	Standard event status enable command
*ESE?	Standard event status enable query
*ESR?	Standard event status register query
*IDN?	Identification query
*OPC	Operation complete command
*OPC?	Operation complete query
*RST	Reset command
*SRE	Service request enable command
*SRE?	Service request enable query
*STB?	Read status byte query
*TST?	Self-test query
*WAI	Wait for pending operations to be completed

IEEE 488.2 Required Commands

		*CLS
Description	The *CLS command clears the Standard Event Status Register and the Error/Event Queue.	
Syntax	*CLS	
Parameter(s)	None	

ESE*Description**

The *ESE command sets the Standard Event Status Enable Register bits, as defined in the table below. This register contains a mask value for the bits to be enabled in the Standard Event Status Register.

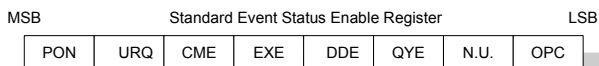
**Syntax**

*ESE<wsp> <RegisterValue>

Parameter(s)

RegisterValue:

The program data syntax for <RegisterValue> is defined as a <DECIMAL NUMERIC PROGRAM DATA> element.

The <RegisterValue>, expressed in base 2, represents the bit values of the Standard Event Status Enable Register.

***ESE**

The table below shows the contents of this register.

Bit	Weight	Meaning
PON	128	Power ON Enable
URQ	64	User ReQuest Enable
CMD	32	CoMmanD Error Enable
EXE	16	Execution Error Enable
DDE	8	Device Dependent Error Enable
QRY	4	QueRry Error Enable
N.U.	2	Not used
OPC	1	Operation Complete Enable

A value of 1 in the Enable Register enables the corresponding bit in the Status Register, a value of 0 disables the bit. The value of the <RegisterValue> shall be in the range of 0 through 255.

Example(s)

*ESE 25
where 25 = (bit EXE, bit DDE and bit OPC)

*ESE 0
clears the content of the Standard Event Status Enable register

See Also

*ESE?
*ESR?

***ESE?**

Description With the *ESE? query you can determine the current contents of the Standard Event Status Enable Register. See the contents of this register below.

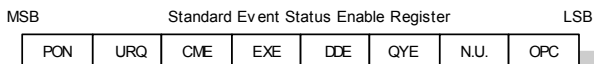

Syntax *ESE?

Parameter(s) None

Response Syntax <RegisterValue>

IEEE 488.2 and Specific Command Reference

IEEE 488.2 Required Commands

*ESE?

Response(s)

RegisterValue:

The response data syntax for <RegisterValue> is defined as a <NR1 NUMERIC RESPONSE DATA> element.

The <RegisterValue> ranges from 0 through 255.

The <RegisterValue> value expressed in base 2 (binary) represents the bit values of the Standard Event Status Enable register. See below.

Bit	Weight	Meaning
PON	128	Power ON Enable
URQ	64	User ReQuest Enable
CMD	32	CoMmand Error Enable
EXE	16	Execution Error Enable
DDE	8	Device Dependent Error Enable
QRY	4	QueRry Error Enable
N.U.	2	Not used
OPC	1	Operation Complete Enable

Example(s)

*ESE? returns 133
where 133 = (bit PON, bit QYE and bit OPC)

See Also

*ESE
*ESR?

*ESR?

Description

With the *ESR? query you can determine the current contents of the Standard Event Status Register. Reading the Standard Event Status Register clears it. See the contents of this register below.

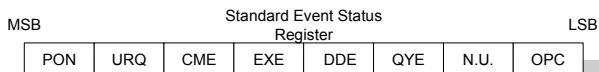
**Syntax**

*ESR?

Parameter(s)

None

Response Syntax

<RegisterValue>

IEEE 488.2 and Specific Command Reference

IEEE 488.2 Required Commands

***ESR?**

Response(s)

RegisterValue:

The response data syntax for <RegisterValue> is defined as a <NR1 NUMERIC RESPONSE DATA> element.

The <RegisterValue> ranges from 0 through 255.

The <RegisterValue> value expressed in base 2 (binary) represents the bit values of the Standard Event Status register. See below.

Bit	Weight	Meaning
PON	128	Power ON Enable
URQ	64	User ReQuest Enable
CMD	32	CoMmanD Error Enable
EXE	16	Execution Error Enable
DDE	8	Device Dependent Error Enable
QRY	4	QueRry Error Enable
N.U.	2	Not used
OPC	1	Operation Complete Enable

Example(s)

*ESR? returns 33
where 33 = (bit CME and bit OPC)

See Also

*ESE
*ESE?

***IDN?**

Description	The intent of the *IDN? query is for the unique identification of devices over the system interface.
Syntax	*IDN?
Parameter(s)	None
Response Syntax	<Identification>
Response(s)	<p><i>Identification:</i></p> <p>The response data syntax for <Identification> is defined as an <ARBITRARY ASCII RESPONSE DATA> element.</p>

The response syntax for the *IDN? query, <Identification> is defined as an <ARBITRARY ASCII RESPONSE DATA> element. This implies that the *IDN? query should be the last <QUERY MESSAGE UNIT> in a <TERMINATED PROGRAM MESSAGE>.

The response is organized into four fields separated by commas. The field definitions are as follows:

Field 1 (Manufacturer): EXFO Inc.
Field 2 (Model): Instrument Model

IEEE 488.2 and Specific Command Reference

IEEE 488.2 Required Commands

***IDN?**

Field 3 (Serial number): ASCII character (0 if not available)

Field 4 (Firmware level): ASCII character (0 if not available)

ASCII character 0 represents a single ASCII-encoded byte with a value of 30 (48 decimal).

The presence of data in all fields is mandatory. If either field 3 or 4 is not available, the ASCII character 0 shall be returned for that field. A field may contain any 7-bit ASCII-encoded bytes in the range of 20 through 7E (32 through 126 decimal) except commas (2C, 44 decimal) and semicolons (3B, 59 decimal).

Example(s)

*IDN? returns EXFO Inc.,
FTB-2 Pro,125-2A55,1.0.1.97

Notes

The overall length of the *IDN? response is less than or equal to 72 characters.

***OPC**

Description	The *OPC command makes synchronization between the instrument and an external controller possible. The *OPC command causes the instrument to set bit 0 (Operation Complete) in the Standard Event Status Register to the TRUE (logic 1) state when the instrument completes all pending operations. Detection of the Operation Complete message can be accomplished by continuous polling of the Standard Event Status Register using the *ESR? common query command. However, using a service request eliminates the need to poll the Standard Event Status Register thereby freeing the controller to do other useful work.
Syntax	*OPC
Parameter(s)	None
See Also	*OPC? *WAI

*OPC?

Description	The *OPC? query makes possible the synchronization between the instrument and an external controller by reading the Output Queue or by waiting for a service request on the Message Available (MAV) bit in the Status Byte Register. The *OPC? query causes the instrument to place an ASCII character, 1, into its Output Queue when the device completes all pending operations. A consequence of this action is that the MAV bit in the Status Byte Register is set to state 1.
Syntax	*OPC?
Parameter(s)	None
Response Syntax	<Acknowledge>
Response(s)	<i>Acknowledge:</i> The response data syntax for <Acknowledge> is defined as a <NR1 NUMERIC RESPONSE DATA> element. The <Acknowledge> response is a single ASCII-encoded byte corresponding to 1. The receipt of an <Acknowledge> response indicates that all pending selected device operations have been completed.
Example(s)	*OPC? returns 1
See Also	*OPC *WAI

RST*Description**

The *RST command performs a device reset. This command is the third reset level in a three-level reset strategy. The Reset command shall do the following:

- a) Sets the device-specific functions to a known state that is independent of the past-use history of the device.
- b) Forces the device into OCIS state (Operation complete Command Idle State).
- c) Forces the device into OQIS state (Operation complete Query Idle State).

The Reset command explicitly DOES NOT affect the following:

- a) The state of the Communication interface.
- b) The Output Queue.
- c) Any Event Enable Register setting, including the Standard Event Status Enable Register setting.
- d) Any Event Register setting, including the Standard Event Status Register settings.
- e) Calibration data that affects device specifications.
- f) The Service Request Enable Register setting.

Syntax

*RST

Parameter(s)

None

IEEE 488.2 and Specific Command Reference

IEEE 488.2 Required Commands

***SRE**

Description

The *SRE command sets the Service Request Enable Register bits. See the contents of this register below. This register contains a mask value to enable the bits in the Status Byte Register.

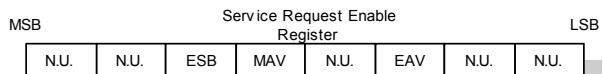

Syntax

*SRE<wsp> <RegisterValue>

Parameter(s)

RegisterValue:

The program data syntax for <RegisterValue> is defined as a <DECIMAL NUMERIC PROGRAM DATA> element.

The <RegisterValue> value ranges from 0 through 255.

The <RegisterValue>, expressed in base 2 (binary), represents the bit values of the Service Request Enable Register.

***SRE**

See the contents of this register below.

Bit	Weight	Meaning
N.U.	128	Not used
N.U.	64	Not used
ESB	32	Event Summary Bit Enable
MAV	16	Message AVailable Enable
N.U.	8	Not used
EAV	4	Error / Event AVailable Enable
N.U.	2	Not used
N.U.	1	Not used

A bit value of zero shall indicate a disabled condition.

Example(s)

*SRE 52
where 52 = (bit ESB, bit MAV and bit EAV)

See Also

*SRE?
*STB?

IEEE 488.2 and Specific Command Reference

IEEE 488.2 Required Commands

***SRE?**

Description

With the *SRE? query you can determine the current contents of the Service Request Enable Register. See the contents of this register below.

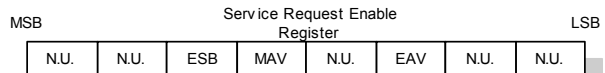

Bit	Weight	Meaning
N.U.	128	Not used
N.U.	64	Not used
ESB	32	Event Summary Bit Enable
MAV	16	Message AAvailable Enable
N.U.	8	Not used
EAV	4	Error / Event AAvailable Enable
N.U.	2	Not used
N.U.	1	Not used

Syntax

*SRE?

Parameter(s)

None

Response Syntax

<RegisterValue>

***SRE?**

Response(s)

RegisterValue:

The response data syntax for <RegisterValue> is defined as a <NR1 NUMERIC RESPONSE DATA> element.

The <RegisterValue> ranges from 0 through 255.

When converted to binary (base 2), the <RegisterValue> represents the current bit values of the Service Request Enable Register.

Example(s)

*SRE returns 32 (bit ESB)

See Also

*SRE
*STB?

IEEE 488.2 and Specific Command Reference

IEEE 488.2 Required Commands

*STB?

Description

With the *STB? query you can read the status byte and Master Summary Status bit. See the content of this register below.

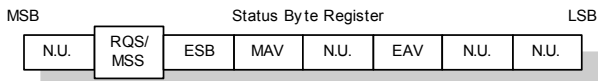
**Syntax**

*STB?

Parameter(s)

None

Response Syntax

<RegisterValue>

STB?*Response(s)***RegisterValue:*

The response data syntax for <RegisterValue> is defined as a <NR1 NUMERIC RESPONSE DATA> element.

The <RegisterValue> ranges from 0 through 255.

The <RegisterValue> value, expressed in base 2 (binary) represents the bit values of the Status Byte Register. See the contents of this register below.

Bit	Weight	Meaning
N.U.	128	Not used
RQS/ MSS	64	ReQuest Service (read by serial polling)/MaSter Summary bit (read by *STB?)
ESB	32	Event Summary Bit Enable
MAV	16	Message AVailable Enable
N.U.	8	Not used
EAV	4	Error / Event AVailable Enable
N.U.	2	Not used
N.U.	1	Not used

Example(s)

*STB? returns 68
where 68 = (bit MSS and bit EAV)

See Also

*SRE
*SRE?

IEEE 488.2 and Specific Command Reference

IEEE 488.2 Required Commands

*TST?	
Description	The *TST? query causes an internal self-test and places a response into the Output Queue indicating whether or not the device completed the self-test without any detected errors. Upon successful completion of *TST?, the device settings is restored to their values prior to the *TST?.
Syntax	*TST?
Parameter(s)	None
Response Syntax	<Result>
Response(s)	<p><i>Result:</i></p> <p>The response data syntax for <Result> is defined as a <NR1 NUMERIC RESPONSE DATA> element.</p> <p>The <Result> value ranges from -32767 through +32767.</p> <p>A <Result> with a value of zero indicates that the self-test has been completed without errors detected. A <Result> with a value not equal to zero indicates that the self-test was not completed or was completed with errors detected.</p>
Example(s)	*TST? returns 0 (self-test was completed with success)

***WAI**

Description	The *WAI command shall prevent the device from executing any further commands or queries until the no-operation-pending flag becomes TRUE.
Syntax	*WAI
Parameter(s)	None
Example(s)	*WAI
See Also	*OPC *OPC?

Specific Commands—Quick Reference

The table below contains a summary of the FTB-2 and FTB-2 Pro specific commands. These commands are fully explained on the following pages.

Command						Parameter(s)
FORMat	[DATA]					ASCIi PACKed[,<Length>]
	[DATA]?					
INSTRument	CATalog?					
	CATalog	FULL?				
SYSTem	DATE					<Year>,<Month>,<Day>
	DATE?					
	ERRor	[NEXT]?				
	TIME					<Hour>,<Minute>,<Seconds>
	TIME?					
	VERSIon?					

Specific Commands

:FORMat[:DATA]

Description

The FORMat[:DATA] command selects the data format and <Length>. The <Length> parameter is optional for all data format, its meaning is dependent on the data format selected.

If PACKed type is selected, the data is transferred in a <DEFINITE BLOCK RESPONSE DATA>. The ASCii-type data is automatically identified by its syntax. Therefore, in these cases, the FORMat subsystem is only necessary to determine the output format.

At *RST, ASCii is selected as the default data format and the <Length> is set to 0.

Syntax

:FORMat[:DATA] <wsp>ASCii|PACKed[, <Length>]

Parameter(s)

► *Type:*

The program data syntax for the first parameter is defined as a <CHARACTER PROGRAM DATA> element. The allowed <CHARACTER PROGRAM DATA> elements for this parameter are: ASCii|PACKed.

:FORMat[:DATA]

In ASCii format, the numeric data is transferred to ASCii bytes in <NR1 NUMERIC RESPONSE DATA>, <NR2 NUMERIC RESPONSE DATA> or <NR3 NUMERIC RESPONSE DATA> representation, as appropriate.

In PACKed format, data is transferred to a <DEFINITE BLOCK RESPONSE DATA>, in a manner specified in the device documentation.

► *Length:*

The program data syntax for <Length> is defined as a <DECIMAL NUMERIC PROGRAM DATA> element.

When ASCii data format is selected, the optional <Length> parameter specifies the number of significant digits to be returned. A <Length> value of zero indicates that the device selects the number of significant digits to be returned. When a <Length> of zero has been specified, the FORMat[:DATA]? query returns zero as its second parameter.

When the PACKed data format is selected, the optional parameter <Length> it not used.

Example(s)

FORM ASC
FORM ASC,6
FORM:DATA PACKED

See Also

FORMat[:DATA]?

:FORMat[:DATA]?

Description	<p>The FORMat[:DATA]? query returns the data format and the <Length>.</p> <p>At *RST, ASCii is selected as the default data format and the <Length> is set to 0.</p>
Syntax	:FORMat[:DATA]?
Parameter(s)	None
Response Syntax	<Type>,<Length>
Response(s)	<p>➤ <i>Type:</i></p> <p>The response data syntax for <Type> is defined as a <CHARACTER RESPONSE DATA> element.</p> <p>The ASCII <Type> is returned when numeric data is transferred to ASCII bytes in <NR1 NUMERIC RESPONSE DATA>, <NR2 NUMERIC RESPONSE DATA> or <NR3 NUMERIC RESPONSE DATA> representation, as appropriate.</p> <p>The PACKED <Type> is returned when data is transferred to a <DEFINITE BLOCK RESPONSE DATA>, as specified in the device documentation.</p> <p>➤ <i>Length:</i></p> <p>The response data syntax for <Length> is defined as a <NR1 NUMERIC RESPONSE DATA> element.</p>

:FORMat[:DATA]?

When the data is returned in ASCII, the <Length> is the number of significant digits to be returned. A <Length> value of zero indicates that the device selects the number of significant digits to be returned.

When the data is returned in PACKED <Type>, the <Length> is not used and always returns 0.

Example(s)

FORM? returns ASCII,6

FORM? returns PACKED,0

See Also

FORMat[:DATA]?

:INSTrument:CATalog?

Description	<p>The INSTrument:CATalog? query returns a comma-separated list of <STRING RESPONSE DATA>, which contains the names of all logical instruments and groups. If no logical instruments are defined, a single null <STRING RESPONSE DATA> is returned.</p> <p>This is not affected by a *RST command.</p>
Syntax	:INSTrument:CATalog?
Parameter(s)	None
Response Syntax	<Catalog>
Response(s)	<p><i>Catalog:</i></p> <p>The response data syntax for <Catalog> is defined as a <STRING RESPONSE DATA> element.</p> <p>The list of <STRING PROGRAM DATA> contains the names of all logical instruments and groups.</p>
Example(s)	INST:CAT? returns “FTB-5240BP Optical Spectrum Analyzer (1250nm-1650nm)”,”FTB-5240S Optical Spectrum Analyzer (1250nm-1650nm)”
See Also	INSTrument:CATalog:FULL?

:INSTrument:CATalog:FULL?

Description	<p>The INSTrument:CATalog:FULL? returns a list of <STRING RESPONSE DATA> - <NR1 NUMERIC RESPONSE DATA> pairs. The <STRING RESPONSE DATA> contains the name of the logical instrument. The immediately following <NR1 NUMERIC RESPONSE DATA> formatted number is its associated logical instrument number. All response data elements are separated by commas. If no logical instrument is defined, a null <STRING RESPONSE DATA> value followed by a zero is returned.</p> <p>This is not affected by a *RST command.</p>
Syntax	:INSTrument:CATalog:FULL?
Parameter(s)	None
Response Syntax	<Catalog>
Response(s)	<p><i>Catalog:</i></p> <p>The response data syntax for <Catalog> is defined as a <STRING RESPONSE DATA> element.</p> <p>The list of <STRING RESPONSE DATA> contains the names of all logical instruments and groups. The immediately following <NR1 NUMERIC RESPONSE DATA> formatted number is its associated logical instrument number.</p>
Example(s)	<p>INST:CAT:FULL? returns “FTB-5240BP Optical Spectrum Analyzer (1250nm-1650nm)”,1,”FTB-5240S Optical Spectrum Analyzer (1250nm-1650nm)”,2</p>
See Also	INSTrument:CATalog?.

:SYSTem:DATE

Description	<p>The SYSTem:DATE command is used to set the device's internal calendar.</p> <p>This is not affected by a *RST command.</p>
Syntax	:SYSTem:DATE<wsp><Year>,<Month>,<Day> >
Parameter(s)	<p>➤ <i>Year:</i></p> <p>The program data syntax for <Year> is defined as a <DECIMAL NUMERIC PROGRAM DATA> element.</p> <p>The <Year> is rounded to the nearest integer. Its range is limited by the capability of the device. The year shall be entered as a four-digit number, including century and millennium information.</p> <p>➤ <i>Month:</i></p> <p>The program data syntax for <Month> is defined as a <DECIMAL NUMERIC PROGRAM DATA> element.</p> <p>The <Month> is rounded to the nearest integer. Its range is 1 to 12 inclusive. The number 1 corresponds to January, 2 to February, and so on.</p>

:SYSTem:DATE

➤ *Day:*

The program data syntax for <Day> is defined as a <DECIMAL NUMERIC PROGRAM DATA> element.

The <Day> is rounded to the nearest integer. It ranges from 1 to the number of days in the month from the previous parameter. This command keeps track of the number of days in each month, accounting for leap years through the range of years that it accepts.

Example(s)

SYST:DATE 2014,07,29

See Also

SYSTem:DATE?

:SYSTem:DATE?

Description	The SYSTem:DATE query returns the instrument's internal calendar. This is not affected by a *RST command.
Syntax	:SYSTem:DATE?
Parameter(s)	None
Response Syntax	<Year>,<Month>,<Day>

:SYSTem:DATE?

Response(s)

➤ *Year:*

The response data syntax for <Year> is defined as a <NR1 NUMERIC RESPONSE DATA> element.

The <Year> is a four-digit number, including century and millennium information.

➤ *Month:*

The response data syntax for <Month> is defined as a <NR1 NUMERIC RESPONSE DATA> element.

The <Month> ranges from 1 to 12, inclusively. The number 1 corresponds to January, 2 to February, and so on.

➤ *Day:*

The response data syntax for <Day> is defined as a <NR1 NUMERIC RESPONSE DATA> element.

The <Day> ranges from 1 to the number of days in the month from the previous field. This command keeps track of the number of days in each month, accounting for leap years through the range of years that it accepts.

Example(s)

SYST:DATE? returns 2017,07,29

See Also

SYSTem:DATE

:SYSTem:ERRor[:NEXT]?

Description	<p>The SYSTem:ERRor[:NEXT]? queries the error/event queue for the next item and removes it from the queue. The response message consists of two fields separated by commas <Code>,<Description[,Info]>.</p> <p>SYSTem:ERRor[:NEXT]? is a query only and, therefore, does not have an associated *RST state.</p>
Syntax	:SYSTem:ERRor[:NEXT]?
Parameter(s)	None
Response Syntax	<Code>,<Description[,Info]>
Response(s)	<p>► <i>Code:</i></p> <p>The response data syntax for <Code> is defined as a <NR1 NUMERIC RESPONSE DATA> element.</p> <p>The <Code> is a unique integer in the range [-32768, 32767]. All positive numbers are instrument-dependent. All negative numbers are reserved by the SCPI standard with certain standard error/event codes described in an appendix of this document. The zero value is also used to indicate that no error or event has occurred.</p> <p>► <i>Description[,Info]:</i></p> <p>The response data syntax for <Description[,Info]> is defined as a <STRING RESPONSE DATA> element.</p>

:SYSTem:ERRor[:NEXT]?

The <Description[,Info]> parameter of the full response is a quoted string containing a description followed by information text [,Info]. Each <Code> has a unique and fixed <Description> associated with it. The <Date> and <Time> are appended to the [,info] separated by a semi-colon using the following format:

<Date><wsp><Time> where

<Date> = Year/Month/Day

<Time> = Hour,Minute,Second (24 hour time)

The maximum length of <Description[,Info]> is 255 characters. For standard defined error/event <Codes>, the <Description> is sent exactly as indicated in the appendix of this document.

Example(s)

SYST:ERR:NEXT? returns -222,"Data out of range"

SYST:ERR:NEXT? returns -222,"Data out of range,instrument monomodule 5240S, 2014/07/29 14:56:16.259"

:SYSTem:TIME

Description	<p>This device has an internal clock and implements the SYSTem:TIME command to set the clock time over the interface.</p> <p>This is not affected by a *RST command.</p>
Syntax	:SYSTem:TIME<wsp><Hour>,<Minute>,<Seconds>
Parameter(s)	<p>➤ <i>Hour:</i></p> <p>The program data syntax for <Hour> is defined as a <DECIMAL NUMERIC PROGRAM DATA> element.</p> <p>The <Hour> is always rounded to the nearest integer. It ranges from 0 to 23 inclusively. The device accepts hour information in 24-hour format.</p> <p>➤ <i>Minute:</i></p> <p>The program data syntax for <Minute> is defined as a <DECIMAL NUMERIC PROGRAM DATA> element.</p> <p>The <Minute> is always rounded to the nearest integer. It ranges from 0 to 59 inclusively.</p>

:SYSTem:TIME

➤ *Seconds:*

The program data syntax for <Seconds> is defined as a <DECIMAL NUMERIC PROGRAM DATA> element.

The <Second> is rounded to the resolution of the clock. It ranges from 0 to 60. A value of 60 is allowed since rounding may cause a number greater than 59.5 to be rounded to 60. When this element is rounded to 60 it shall be set to 0 and the minute value incremented. Any other carries shall be rippled through the date.

Example(s)

SYST:TIME 12,47,29

See Also

SYSTem:TIME?

:SYSTem:TIME?

Description	This device has an internal clock and implements the SYSTem:DATE? query to get the clock time over the interface. This is not affected by a *RST command.
Syntax	:SYSTem:TIME?
Parameter(s)	None
Response Syntax	<Hour>,<Minute>,<Second>

:SYSTem:TIME?

Response(s)

► *Hour:*

The response data syntax for <Hour> is defined as a <NR1 NUMERIC RESPONSE DATA> element.

The <Hour> ranges from 0 to 23. The instruments returns hour information in 24-hour format.

► *Minute:*

The response data syntax for <Minute> is defined as a <NR1 NUMERIC RESPONSE DATA> element.

The <Minute> ranges from 0 to 59.

► *Second:*

The response data syntax for <Second> is defined as a <NR1 NUMERIC RESPONSE DATA> element.

The <Second> ranges from 0 to 59. The resolution of the clock is the second.

Example(s)

SYST:TIME? returns 16,55,38

See Also

SYSTem:TIME

:SYSTem:VERSion?

Description	<p>The SYSTem:VERSion? query returns a value corresponding to the SCPI version number to which the device complies.</p> <p>The SYSTem:VERSion? is a query only and, therefore, does not have an associated *RST state.</p>
Syntax	:SYSTem:VERSion?
Parameter(s)	None
Response Syntax	<Version>
Response(s)	<p><i>Version:</i></p> <p>The response data syntax for <Version> is defined as a <NR2 NUMERIC RESPONSE DATA> element.</p> <p>The <Version> is shown in the form Year.Revision, where Year represents the year-version (that is 1990) and Revision represents an approved revision number for that year. If no approved revisions are claimed, then this extension is 0.</p>
Example(s)	SYSTem:VERSion? returns 1999.0 (no approved revisions are claimed)

D SCPI-Based Errors

Error Number	Description	Probable Cause
-100	“Command error”	This is the generic syntax error for devices that cannot detect more specific errors. This code indicates only that a Command Error as defined in IEEE 488.2, 11.5.1.1.4 has occurred.
-101	“Invalid character”	A syntactic element contains a character which is invalid for that type; for example, a header containing an ampersand, SETUP&. This error might be used in place of errors -114, -121, -141, and perhaps some others.
-102	“Syntax error”	An unrecognized command or data type was encountered; for example, a string was received when the device does not accept strings.
-103	“Invalid separator”	The parser was expecting a separator and encountered an illegal character; for example, the semicolon was omitted after a program message unit, *EMC 1:CH1:VOLTS 5.
-104	“Data type error”	The parser recognized a data element different than one allowed; for example, numeric or string data was expected but block data was encountered.
-105	“GET not allowed”	A Group Execute Trigger was received within a program message (see IEEE 488.2, 7.7).
-108	“Parameter not allowed”	More parameters were received than expected for the header; for example, the *EMC common command only accepts one parameter, so receiving *EMC 0,1 is not allowed.
-109	“Missing parameter”	Fewer parameters were received than required for the header; for example, the *EMC common command requires one parameter, so receiving *EMC is not allowed.

SCPI-Based Errors

Error Number	Description	Probable Cause
-110	“Command header error”	An error was detected in the header. This error message should be used when the device cannot detect the more specific errors described for errors -111 through -119.
-111	“Header separator error”	A character which is not a legal header separator was encountered while parsing the header; for example, no white space followed the header, thus *GMC"MACRO" is an error.
-112	“Program mnemonic too long”	The header contains more than twelve characters (see IEEE 488.2, 7.6.1.4.1).
-113	“Undefined header”	The header is syntactically correct, but it is undefined for this specific device; for example, *XYZ is not defined for any device.
-114	“Header suffix out of range”	The value of a numeric suffix attached to a program mnemonic (see IEEE 488.2, Syntax and Style section 6.2.5.2) makes the header invalid.
-115	“Unexpected number of parameters”	The number of parameters received does not correspond to the number of parameters expected. This is typically due to an inconsistency with the number of instruments in the selected group (see section on INSTRUMENT:DEFine:GROup).
-120	“Numeric data error”	This error, as well as errors -121 through -129, are generated when parsing a data element which appears to be numeric, including the non-decimal numeric types. This particular error message should be used if the device cannot detect a more specific error.
-121	“Invalid character in number”	An invalid character for the data type being parsed was encountered; for example, an alpha in a decimal numeric or a "9" in octal data.

Error Number	Description	Probable Cause
-123	“Exponent too large”	The magnitude of the exponent was larger than 32000 (see IEEE 488.2, 7.7.2.4.1).
-124	“Too many digits”	The mantissa of a decimal numeric data element contained more than 255 digits excluding leading zeros (see IEEE 488.2, 7.7.2.4.1).
-128	“Numeric data not allowed”	A legal numeric data element was received, but the device does not accept one in this position for the header.
-130	“Suffix error”	This error, as well as errors -131 through -139, are generated when parsing a suffix. This particular error message should be used if the device cannot detect a more specific error.
-131	“Invalid suffix”	The suffix does not follow the syntax described in IEEE 488.2, 7.7.3.2, or the suffix is inappropriate for this device.
-134	“Suffix too long”	The suffix contained more than 12 characters (see IEEE 488.2, 7.7.3.4).
-138	“Suffix not allowed”	A suffix was encountered after a numeric element which does not allow suffixes.
-140	“Character data error”	This error, as well as errors -141 through -149, are generated when parsing a character data element. This particular error message should be used if the device cannot detect a more specific error.
-141	“Invalid character data”	Either the character data element contains an invalid character or the particular element received is not valid for the header.
-144	“Character data too long”	The character data element contains more than twelve characters (see IEEE 488.2, 7.7.1.4).
-148	“Character data not allowed”	A legal character data element was encountered where prohibited by the device.

SCPI-Based Errors

Error Number	Description	Probable Cause
-150	“String data error”	This error, as well as errors -151 through -159, are generated when parsing a string data element. This particular error message should be used if the device cannot detect a more specific error.
-151	“Invalid string data”	A string data element was expected, but was invalid for some reason (see IEEE 488.2, 7.7.5.2); for example, an END message was received before the terminal quote character.
-158	“String data not allowed”	A string data element was encountered but was not allowed by the device at this point in parsing.
-160	“Block data error”	This error, as well as errors -161 through -169, are generated when parsing a block data element. This particular error message should be used if the device cannot detect a more specific error.
-161	“Invalid block data”	A block data element was expected, but was invalid for some reason (see IEEE 488.2, 7.7.6.2); for example, an END message was received before the length was satisfied.
-168	“Block data not allowed”	A legal block data element was encountered but was not allowed by the device at this point in parsing.
-170	“Expression error”	This error, as well as errors -171 through -179, are generated when parsing an expression data element. This particular error message should be used if the device cannot detect a more specific error.
-171	“Invalid expression”	The expression data element was invalid (see IEEE 488.2, 7.7.7.2); for example, unmatched parentheses or an illegal character.
-178	“Expression data not allowed”	A legal expression data was encountered but was not allowed by the device at this point in parsing.

Error Number	Description	Probable Cause
-180	"Macro error"	This error, as well as errors -181 through -189, are generated when defining a macro or executing a macro. This particular error message should be used if the device cannot detect a more specific error.
-181	"Invalid outside macro definition"	Indicates that a macro parameter placeholder ($\$(\text{number})$) was encountered outside of a macro definition.
-183	"Invalid inside macro definition"	Indicates that the program message unit sequence, sent with a *DDT or *DMC command, is syntactically invalid (see IEEE 488.2, 10.7.6.3).
-184	"Macro parameter error"	Indicates that a command inside the macro definition had the wrong number or type of parameters.
-200	"Execution error"	This is the generic syntax error for devices that cannot detect more specific errors. This code indicates only that an Execution Error as defined in IEEE 488.2, 11.5.1.1.5 has occurred.
-201	"Invalid while in local"	Indicates that a command is not executable while the device is in local due to a hard local control (see IEEE 488.2, 5.6.1.5); for example, a device with a rotary switch receives a message which would change the switches state, but the device is in local so the message can not be executed.
-202	"Settings lost due to rtl"	Indicates that a setting associated with a hard local control (see IEEE 488.2, 5.6.1.5) was lost when the device changed to LOCS from REMS or to LWLS from RWLS.
-203	"Command protected"	Indicates that a legal password-protected program command or query could not be executed because the command was disabled.

SCPI-Based Errors

Error Number	Description	Probable Cause
-210	“Trigger error”	-----
-211	“Trigger ignored”	Indicates that a GET, *TRG, or triggering signal was received and recognized by the device but was ignored because of device timing considerations; for example, the device was not ready to respond. Note: a DT0 device always ignores GET and treats *TRG as a Command Error.
-212	“Arm ignored”	Indicates that an arming signal was received and recognized by the device but was ignored.
-213	“Init ignored”	Indicates that a request for a measurement initiation was ignored as another measurement was already in progress.
-214	“Trigger deadlock”	Indicates that the trigger source for the initiation of a measurement is set to GET and subsequent measurement query is received. The measurement cannot be started until a GET is received, but the GET would cause an INTERRUPTED error.
-215	“Arm deadlock”	Indicates that the arm source for the initiation of a measurement is set to GET and subsequent measurement query is received. The measurement cannot be started until a GET is received, but the GET would cause an INTERRUPTED error.
-220	“Parameter error”	Indicates that a program data element related error occurred. This error message should be used when the device cannot detect the more specific errors described for errors -221 through -229.
-221	“Settings conflict”	Indicates that a legal program data element was parsed but could not be executed due to the current device state (see IEEE 488.2, 6.4.5.3 and 11.5.1.1.5).

Error Number	Description	Probable Cause
-222	"Data out of range"	Indicates that a legal program data element was parsed but could not be executed because the interpreted value was outside the legal range as defined by the device (see IEEE 488.2, 11.5.1.1.5).
-223	"Too much data"	Indicates that a legal program data element of block, expression, or string type was received that contained more data than the device could handle due to memory or related device-specific requirements.
-224	"Illegal parameter value"	Used where exact value, from a list of possible, was expected.
-225	"Out of memory"	The device has insufficient memory to perform the requested operation.
-226	"Lists not same length"	Attempted to use LIST structure having individual LIST's of unequal lengths.
-230	"Data corrupt or stale"	Possibly invalid data; new reading started but not completed since last access.
-231	"Data questionable"	Indicates that measurement accuracy is suspect.
-232	"Invalid format"	Indicates that a legal program data element was parsed but could not be executed because the data format or structure is inappropriate. For example when loading memory tables or when sending a SYSTEM:SET parameter from an unknown instrument.

SCPI-Based Errors

Error Number	Description	Probable Cause
-233	“Invalid version”	Indicates that a legal program data element was parsed but could not be executed because the version of the data is incorrect to the device. This particular error should be used when file or block data formats are recognized by the instrument but cannot be executed for reasons of version incompatibility. For example, a not supported file version, a not supported instrument version
-240	“Hardware error”	Indicates that a legal program command or query could not be executed because of a hardware problem in the device. Definition of what constitutes a hardware problem is completely device-specific. This error message should be used when the device cannot detect the more specific errors described for errors -241 through -249.
-241	“Hardware missing”	Indicates that a legal program command or query could not be executed because of missing device hardware; for example, an option was not installed. Definition of what constitutes missing hardware is completely device-specific.
-250	“Mass storage error”	Indicates that a mass storage error occurred. This error message should be used when the device cannot detect the more specific errors described for errors -251 through -259.
-251	“Missing mass storage”	Indicates that a legal program command or query could not be executed because of missing mass storage; for example, an option that was not installed. Definition of what constitutes missing mass storage is device-specific.
-252	“Missing media”	Indicates that a legal program command or query could not be executed because of a missing media; for example, no disk. The definition of what constitutes missing media is device-specific.

Error Number	Description	Probable Cause
-253	"Corrupt media"	Indicates that a legal program command or query could not be executed because of corrupt media; for example, bad disk or wrong format. The definition of what constitutes corrupt media is device-specific.
-254	"Media full"	Indicates that a legal program command or query could not be executed because the media was full; for example, there is no room on the disk. The definition of what constitutes a full media is device-specific.
-255	"Directory full"	Indicates that a legal program command or query could not be executed because the media directory was full. The definition of what constitutes a full media directory is device-specific.
-256	"File name not found"	Indicates that a legal program command or query could not be executed because the file name on the device media was not found; for example, an attempt was made to read or copy a nonexistent file. The definition of what constitutes a file not being found is device-specific.
-257	"File name error"	Indicates that a legal program command or query could not be executed because the file name on the device media was in error; for example, an attempt was made to copy to a duplicate file name. The definition of what constitutes a file name error is device-specific.
-258	"Media protected"	Indicates that a legal program command or query could not be executed because the media was protected; for example, the write-protect tab on a disk was present. The definition of what constitutes protected media is device-specific.

SCPI-Based Errors

Error Number	Description	Probable Cause
-260	“Expression error”	[Indicates that a expression program data element related error occurred. This error message should be used when the device cannot detect the more specific errors described for errors -261 through -269.]
-261	“Math error in expression”	[Indicates that a syntactically legal expression program data element could not be executed due to a math error; for example, a divide-by-zero was attempted. The definition of math error is device-specific.]
-270	“Macro error”	[Indicates that a macro-related execution error occurred. This error message should be used when the device cannot detect the more specific errors described for errors -271 through -279.]
-271	“Macro syntax error”	[Indicates that a syntactically legal macro program data sequence, according to IEEE 488.2, 10.7.2, could not be executed due to a syntax error within the macro definition (see IEEE 488.2, 10.7.6.3).]
-272	“Macro execution error”	[Indicates that a syntactically legal macro program data sequence could not be executed due to some error in the macro definition (see IEEE 488.2, 10.7.6.3).]
-273	“Illegal macro label”	[Indicates that the macro label defined in the *DMC command was a legal string syntax, but could not be accepted by the device (see IEEE 488.2, 10.7.3 and 10.7.6.2); for example, the label was too long, the same as a common command header, or contained invalid header syntax.]
-274	“Macro parameter error”	[Indicates that the macro definition improperly used a macro parameter placeholder (see IEEE 488.2, 10.7.3).]

Error Number	Description	Probable Cause
-275	“Macro definition too long”	[Indicates that a syntactically legal macro program data sequence could not be executed because the string or block contents were too long for the device to handle (see IEEE 488.2, 10.7.6.1).]
-276	“Macro recursion error”	[Indicates that a syntactically legal macro program data sequence could not be executed because the device found it to be recursive (see IEEE 488.2, 10.7.6.6).]
-277	“Macro redefinition not allowed”	[Indicates that a syntactically legal macro label in the *DMC command could not be executed because the macro label was already defined (see IEEE 488.2, 10.7.6.4).]
-278	“Macro header not found”	[Indicates that a syntactically legal macro label in the *GMC? query could not be executed because the header was not previously defined.]
-280	“Program error”	[Indicates that a downloaded program-related execution error occurred. This error message should be used when the device cannot detect the more specific errors described for errors -281 through -289. A downloaded program is used to add algorithmic capability to a device. The syntax used in the program and the mechanism for downloading a program is device-specific.]
-281	“Cannot create program”	[Indicates that an attempt to create a program was unsuccessful. A reason for the failure might include not enough memory.]
-282	“Illegal program name”	[The name used to reference a program was invalid; for example, redefining an existing program, deleting a nonexistent program, or in general, referencing a nonexistent program.]
-283	“Illegal variable name”	[An attempt was made to reference a nonexistent variable in a program.]

SCPI-Based Errors

Error Number	Description	Probable Cause
-284	“Program currently running”	[Certain operations dealing with programs may be illegal while the program is running; for example, deleting a running program might not be possible.]
-285	“Program syntax error”	[Indicates that a syntax error appears in a downloaded program. The syntax used when parsing the downloaded program is device-specific.]
-286	“Program runtime error”	-----
-290	“Memory use error”	[Indicates that a user request has directly or indirectly caused an error related to memory or <data_handle>, this is not the same as “bad” memory.]
-291	“Out of memory”	-----
-292	“Referenced name does not exist”	-----
-293	“Referenced name already exist”	-----
-294	“Incompatible type”	[Indicates that the type or structure of a memory item is inadequate]
-300	“Device-specific error”	[This is the generic device-dependent error for devices that cannot detect more specific errors. This code indicates only that a Device-Dependent Error as defined in IEEE 488.2, 11.5.1.1.6 has occurred.]
-310	“System error”	[Indicates that some error, termed "system error" by the device, has occurred. This code is device-dependent.]
-311	“Memory error”	[Indicates some physical fault in the device's memory, such as parity error.]

Error Number	Description	Probable Cause
-312	"PUD memory lost"	[Indicates that the protected user data saved by the *PUD command has been lost.]
-313	"Calibration memory lost"	[Indicates that nonvolatile calibration data used by the *CAL? command has been lost.]
-314	"Save/Recall memory lost"	[Indicates that the nonvolatile data saved by the *SAV? command has been lost.]
-315	"Configuration memory lost"	[Indicates that nonvolatile configuration data saved by the device has been lost. The meaning of this error is device-specific.]
-320	"Storage fault"	[Indicates that the firmware detected a fault when using data storage. This error is not an indication of physical damage or failure of any mass storage element.]
-321	"Out of memory"	[An internal operation needed more memory than was available.]
-330	"Self-test failed"	-----
-340	"Calibration failed"	-----
-350	"Queue overflow"	[A specific code entered into the queue in lieu of the code that caused the error. This code indicates that there is no room in the queue and an error occurred but was not recorded.]
-360	"Communication error"	[This is the generic communication error for devices that cannot detect the more specific errors described for errors -361 through -363.]
-361	"Parity error in program message"	[Parity bit not correct when data received for example, on a serial port.]
-362	"Framing error in program message"	[A stop bit was not detected when data was received for example, on a serial port (for example, a baud rate mismatch).]

SCPI-Based Errors

Error Number	Description	Probable Cause
-363	“Input buffer overrun”	[Software or hardware input buffer on serial port overflows with data caused by improper or nonexistent pacing.]
-365	“Time out error”	[This is a generic device-dependent error.]
-400	“Query error”	[This is the generic query error for devices that cannot detect more specific errors. This code indicates only that a Query Error as defined in IEEE 488.2, 11.5.1.1.7 and 6.3 has occurred.]
-410	“Query INTERRUPTED”	[Indicates that a condition causing an INTERRUPTED Query error occurred (see IEEE 488.2, 6.3.2.3); for example, a query followed by DAB or GET before a response was completely sent.]
-420	“Query UNTERMINATED”	[Indicates that a condition causing an UNTERMINATED Query error occurred (see IEEE 488.2, 6.3.2.2); for example, the device was addressed to talk and an incomplete program message was received.]
-430	“Query DEADLOCKED”	[Indicates that a condition causing an DEADLOCKED Query error occurred (see IEEE 488.2, 6.3.1.7); for example, both input buffer and output buffer are full and the device cannot continue.]
-440	“Query UNTERMINATED after indefinite response”	[Indicates that a query was received in the same program message after an query requesting an indefinite response was executed (see IEEE 488.2, 6.5.7.5).]
-500	“Power on”	[The instrument has detected an off to on transition in its power supply.]
-600	“User request”	[The instrument has detected the activation of a user request local control.]

Error Number	Description	Probable Cause
-700	"Request control"	[The instrument requested to become the active IEEE 488.1 controller-in-charge.]
-800	"Operation complete"	[The instrument has completed all selected pending operations in accordance with the IEEE 488.2, 12.5.2 synchronization protocol.]

E **COM Properties and Events**

The FTB-2 and FTB-2 Pro also provides objects based on Microsoft Component Object Model (COM). COM defines a common way to access and create software components and services.

COM promotes the integration and the reuse of software components, as well as interoperability. In order to interoperate, components developed in different languages must adhere to a binary structure specified by Microsoft.

OLE and ActiveX are based on COM. Many programming languages can create and use COM components.

You can build your own programs using the provided properties and events via the IcSCPIAccess interface (available on your unit). For information on how to configure your FTB-2 and FTB-2 Pro for DCOM control, see *Configuring DCOM Access to Your Unit* on page 222.

ActiveX (COM/DCOM)—Quick Reference

The following diagram illustrates the different properties and events available.

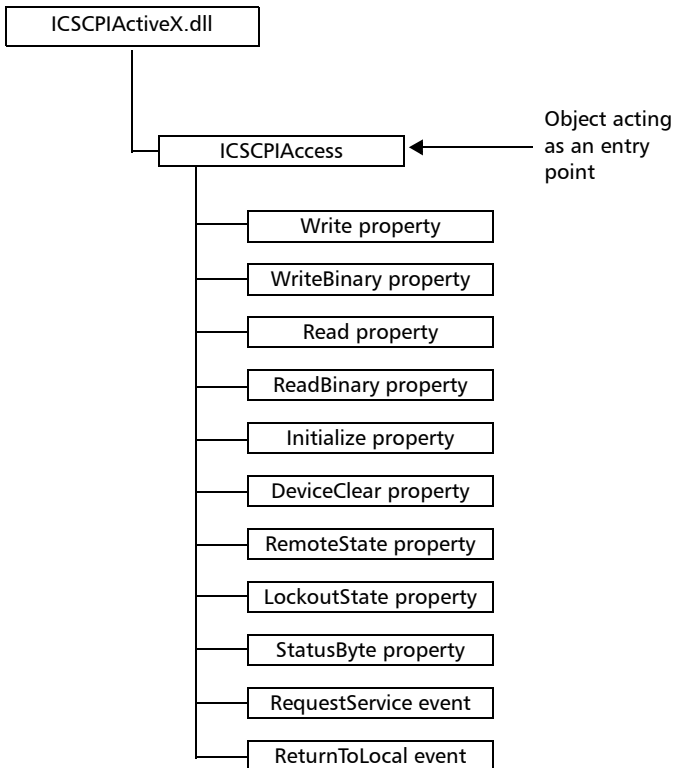

These properties and events are fully explained in the following pages.

Properties

Write

Description	With this method you can send a program message (single command or compound of commands) to the device input buffer.
Syntax	object. <i>Write</i> (<i>Message</i>)
Parameter(s)	<i>Message</i> : Required. A string value corresponding to the program message to be sent.
Possible error(s)	<i>Timeout</i> : This error will occur if the operation could not be completed within the allowed delay. For information on timeout setting, see <i>Initialize</i> on page 413.

WriteBinary

Description	With this method you can send a program message (single command or compound of commands) as an array of bytes into the device input buffer.
Syntax	<code>object.Write (BinaryArray)</code>
Parameter(s)	<i>BinaryArray</i> : Required. An array of bytes corresponding to the program message to be sent.
Notes	Use this method instead of the <i>Write</i> method if you need to send commands in binary (COM is UNICODE).
Possible error(s)	<i>Timeout</i> : This error will occur if the operation could not be completed within the allowed delay. For information on timeout setting, see <i>Initialize</i> on page 413.



IMPORTANT

Before you retrieve data with the *Read* or *ReadBinary* methods, you must specify the format in which the information must be returned. Details on how to correctly set the format can be found below.

Read

Description	With this method you can retrieve all the data from the device output queue in a UNICODE format.
Syntax	<code>object.Read</code>
Parameter(s)	None.
Response(s)	A string value (in UNICODE format).
Notes	<p>This method must be used in conjunction with the <i>Write</i> method. Always ensure that a query has been previously sent before attempting to read a response from the output queue.</p> <p>To properly set the data format, send the following command (using the <i>Write</i> method): FORM:DATA<wsp>ASCII <number_of_digits> where <number_of_digits> corresponds to the number of digits after the decimal point that you require.</p> <p>Remember that the retrieved data will have to be converted to a numeric format before you can use it in calculations, for example.</p>
Possible error(s)	<p><i>Timeout</i>: This error will occur if the allowed delay has expired before the preceding <i>Write</i> operation could send a response to the output queue. For information on timeout setting, see <i>Initialize</i> on page 413.</p> <p><i>QueryUnterminated</i>: This error will occur if the output queue is empty (for example, no query has been made previously).</p>

ReadBinary

Description	With this method you can retrieve data from the device output queue in a binary format.
Syntax	<code>object.ReadBinary</code>
Parameter(s)	None.
Response(s)	An array of bytes.
Notes	<p>This method must be used in conjunction with the <i>Write</i> method. Always ensure that a query has been previously sent before attempting to read a response from the output queue.</p> <p>To properly set the data format, send the following command (using the <i>Write</i> method): FORM:DATA<wsp>PACKED</p> <p>The retrieved data <i>does not</i> need to be converted to a numeric format before you can use it in calculations, for example.</p> <p>To help you know the actual length of the retrieved data, it has the following structure:</p> <ul style="list-style-type: none">➤ The first byte contains the # character.➤ The byte that immediately follows contains the number of subsequent bytes that you have to check to know the total length.

ReadBinary

For example, if you receive this response (here, values are expressed in decimal instead of binary for easier readability):

```
# 2 1 3 7 5 8 9 2 ...
```

The byte that immediately follows the # contains 2, which means that you have to read the two following bytes to know the length (in bytes) of the retrieved data. The bytes indicate 1 and 3. The length will then be 13 bytes. The actual response will begin at byte number 5, in this case.

Possible error(s)

Timeout: This error will occur if the allowed delay has expired before the preceding *Write* operation could send a response to the output queue. For information on timeout setting, see *Initialize* on page 413.

QueryUnterminated: This error will occur if the output queue is empty (for example, no query has been made previously).

Initialize

Description

With this method you can configure the timeout value that is, the allowed delay for Read and Write operations, in milliseconds.

Syntax

```
object.Initialize(Timeout)
```

Parameter(s)

Timeout: Required. A numeric value corresponding to the delay in milliseconds.

Notes

If the *Initialize* method is not invoked, the default value is 10 000 milliseconds.

COM Properties and Events

Properties

DeviceClear	
Description	This method performs a <i>Device Clear</i> operation as specified in the IEEE 488.1 standard.
Syntax	<code>object.DeviceClear</code>
Parameter(s)	None.

RemoteState	
Description	This property returns or sets the device's remote state.
Syntax	<code>object.RemoteState</code> (to retrieve the state) <code>object.RemoteState=State</code> (to set the state) <i>State</i> : a Boolean value corresponding to: True: Remote False: Local
Parameter(s)	None.
Response(s)	If the property is used to get the device's remote state, the property will return a Boolean value.
Access	Get/Set

LockoutState

Description	This property returns or sets the device's lockout state.
Syntax	<code>object.LockoutState</code> (to retrieve the state) <code>object.LockoutState=State</code> (to set the state) <i>State</i> : a Boolean value corresponding to: True: Lockout False: No lockout
Parameter(s)	None.
Response(s)	If the property is used to get the device's lockout state, the property will return a Boolean value.
Access	Get/Set

StatusByte

Description	This read-only property returns the device's status byte. Refer to IEEE 488.2 standard for status byte description.
Syntax	<code>object.StatusByte</code>
Parameter(s)	None.
Response(s)	A value corresponding to the device's status byte.
Notes	This property can be used in conjunction with <i>RequestService</i> event (see <i>RequestService</i> on page 416) to find out why the device caused a Service Request (SRQ).
Access	Get

Events

RequestService	
Description	This event is triggered whenever the device causes a Service Request (SRQ).
Parameter(s)	None.
Notes	<p>It is the user's responsibility to configure the different registers (*SRE, *ESE) as stated in the IEEE 488.2 standard to receive SRQ.</p> <p>When used in conjunction with <i>StatusByte</i> property (see <i>StatusByte</i> on page 415), this event allows you to determine the cause of the SRQ.</p>

ReturnToLocal	
Description	This event is triggered when the user presses the Local button from the controller's front panel when the device is in Remote state.
Parameter(s)	None.

F **Communicating Through TCP/IP over Telnet**

Introducing TCP/IP over Telnet

The EXFO Instrument Control provides SCPI automation or remote control over Telnet through TCP/IP as a Windows Service that continuously listens to a port from a Telnet server (FTB/IQS) on which modules to be tested are connected.

TCP/IP protocols are used for communication.

Note: *Port 5024 is designated for sending SCPI commands in the Telnet protocol.*

All Windows versions include the Telnet client and the Telnet server components. With these components, you can create a remote command console session on a remote computer.

Commands can be executed simply by logging on the server using the Telnet interface.

There are two types of commands that can be sent over Telnet: SCPI commands and internal protocol commands of the TCP/IP over Telnet service. The internal commands allow you to perform certain actions such as send SCPI commands as a script instead of one by one, force the disconnection of an active session, view the status of modules and of connected clients, etc.

Features

- A client from any operating system (Windows, Linux, or Unix) can use the freely available Telnet components to connect to the service.
- A client can connect to multiple modules at a time.
- A user can connect to multiple modules through single/multiple sessions.
- A client can execute single commands or a batch of commands.
- A user can disconnect any client/session that is already connected.

Activating TCP/IP over Telnet

The TCP/IP over Telnet Service, which is part of the EXFO Instrument Control, is a mediator between the Telnet client and the test instrument.

Any request from the Telnet client will be transferred to IcExecutive. IcExecutive then passes the request to the appropriate instrument. The instrument executes the request and returns the response to IcExecutive and to TCP/IP over Telnet accordingly.

To activate TCP/IP over Telnet:

1. Access the Instrument Control Configuration utility:
 - On an IQS-600: From IQS Manager, click the **Utilities** function tab, and then click **Instrument Control Configuration**.
 - On an FTB-500: From ToolBox, tap the **System Settings** button, then tap **Instrument Control Configuration**.
 - On an FTB-2 or FTB-2 Pro: From ToolBox X, tap the **System Settings** button, then tap **Instrument Control Configuration**.
2. If necessary, click or tap **Change settings**, and then, when the application prompts you to authorize the changes to your unit (identified as “computer”), select **Yes**.

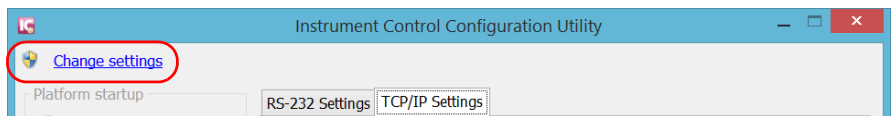

3. Under **Platform Startup**, select **Remote**.

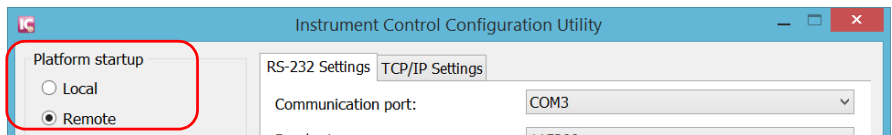

Communicating Through TCP/IP over Telnet

Executing SCPI Commands Over Telnet

4. Under **Communication Type**, select **TCP/IP**.

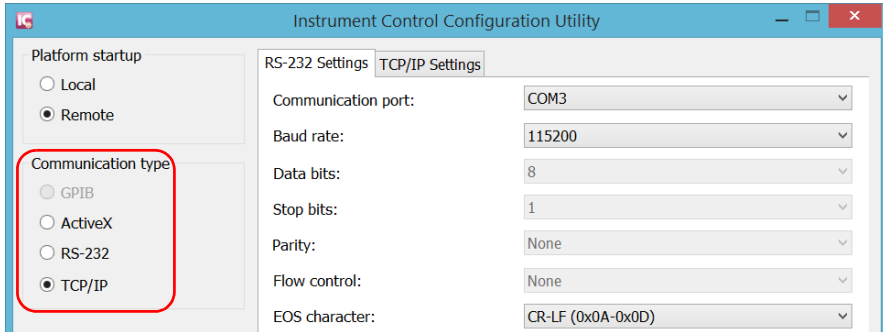

5. Click or tap **Apply**, and then **OK**.
6. Depending on the unit you are using, restart either IQS Manager, ToolBox, or ToolBox X.

Executing SCPI Commands Over Telnet

You can remotely control the modules by executing SCPI commands through TCP/IP over Telnet. The commands are sent remotely from the Telnet client (on a computer) to the Telnet server (in this case, the IQS or FTB unit).

To execute a single SCPI command, you can type or paste the command directly in the Telnet editor window.

To execute multiple SCPI commands (script), you must enclose them within a BEGIN and END block in the Telnet editor window.

You can connect from a remote Windows client or a Linux (or Unix) remote client.

Note: *The Telnet client is available on the FTB-500, FTB-2 Pro, and IQS-600 controller if you intend to use these units as computers to connect to a Telnet server. However, on an FTB-2, the Telnet client is not available. You must use the PuTTY application to establish communication.*

To connect through TCP/IP over Telnet from a remote Windows client:

1. From your computer, start Windows.
2. On the taskbar, click **Start** (Start button () under Windows 8.1) and select **Run**.
3. In the **Open** box, type *telnet*, and then click **OK**.

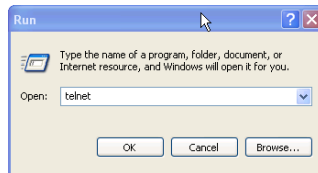

Note: *If you receive an error message, it probably means that the Telnet client is not already activated on your computer. In this case, in the **Open** box, type `pkgmgr /iu:TelnetClient`, and then click **OK** to enable the client. Once it is done, perform step 3 again.*

Communicating Through TCP/IP over Telnet

Executing SCPI Commands Over Telnet

4. In the displayed Telnet editor window, type the `OPEN <IP_ADDRESS_OF_TELNET_SERVER> <PORT>` command to connect to the TCP/IP Telnet Service.

Example: `open 10.192.2.45 5024`

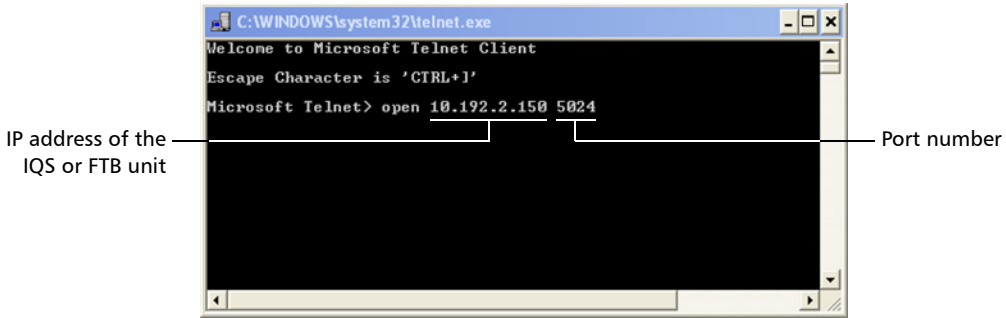

Note: Port 5024 is designated for sending SCPI commands in the Telnet protocol.

5. Press ENTER to establish a connection with the Service.

Once the connection is established, the `READY>` prompt is displayed in the Telnet editor window.

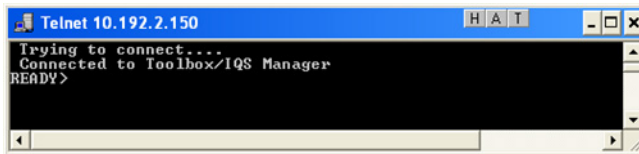

Note: If the connection cannot be established, the *Connection to host lost* message is displayed instead.

6. Enter the desired SCPI commands as follows:

- For a single SCPI command: Type or copy the desired command in the Telnet editor window, and then press ENTER to execute it.

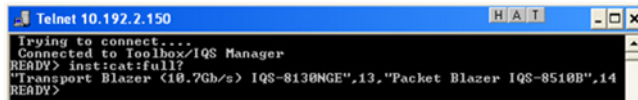

```
Telnet 10.192.2.150
Trying to connect....
Connected to Toolbox/IQS Manager
READY> inst:cat:full?
Transport Blazer <10.7Gb/s> IQS-8130NGE",13,"Packet Blazer IQS-8510B",14
READY>
```

- For multiple SCPI commands: Copy the desired commands from any script file, enclose them in a BEGIN and END block in the Telnet editor window, and then press ENTER. For more information, see *Internal Commands of the TCP/IP over Telnet Protocol* on page 427.

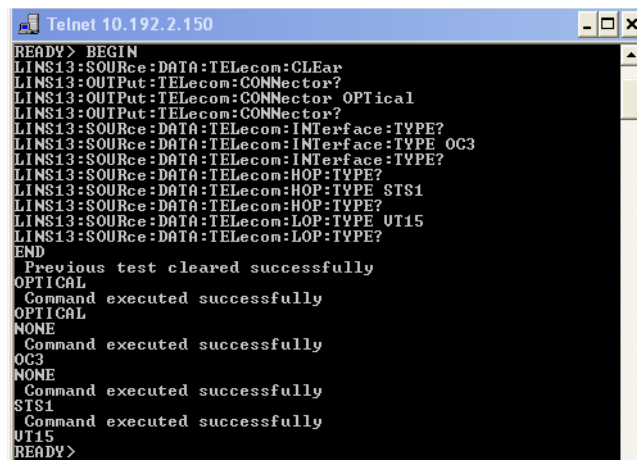

```
Telnet 10.192.2.150
READY> BEGIN
LINS13:SOURce:DATA:TELEcom:CLEAr
LINS13:OUTPut:TELEcom:CONNector?
LINS13:OUTPut:TELEcom:CONNector OPTIcal
LINS13:OUTPut:TELEcom:CONNector?
LINS13:SOURce:DATA:TELEcom:INTErface:TYPE?
LINS13:SOURce:DATA:TELEcom:INTErface:TYPE OC3
LINS13:SOURce:DATA:TELEcom:INTErface:TYPE?
LINS13:SOURce:DATA:TELEcom:HOP:TYPE?
LINS13:SOURce:DATA:TELEcom:HOP:TYPE STS1
LINS13:SOURce:DATA:TELEcom:HOP:TYPE?
LINS13:SOURce:DATA:TELEcom:LOP:TYPE UT15
LINS13:SOURce:DATA:TELEcom:LOP:TYPE?
END
Previous test cleared successfully
OPTICAL
Command executed successfully
OPTICAL
NONE
Command executed successfully
OC3
NONE
Command executed successfully
STS1
Command executed successfully
UT15
READY>
```

Note: Multiple commands that are not enclosed in BEGIN...END blocks will be executed, but problems may occur (results of one command mixed with the results of another one, skipped commands, etc.).

Once at least one valid command is executed, the module is blocked for any other sessions until the module is released. For more information, see *Releasing Modules* on page 426.

Communicating Through TCP/IP over Telnet

Executing SCPI Commands Over Telnet

7. Click  to close the session.

To connect through TCP/IP over Telnet from a remote Linux client:

1. From your computer, right-click on the desktop, and then click **Open Terminal**.

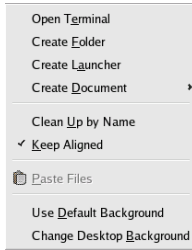

The command prompt is displayed in the Telnet editor window.

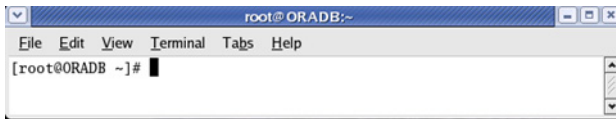

2. Connect to the TCP/IP Telnet Service by typing the `OPEN <IP_ADDRESS_OF_TELNET_SERVER> <PORT>` command:

Example: `open 10.192.2.45 5024`

Note: Port 5024 is designated for sending SCPI commands in the Telnet protocol.

The connection is established when the message **Connected to Toolbox/IQS Manager** is displayed in the Telnet editor window.

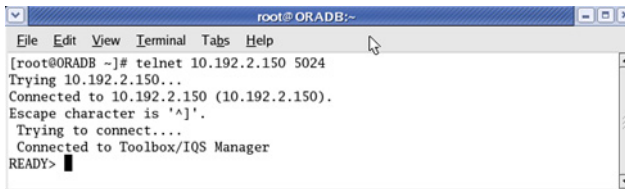

3. Enter the desired SCPI commands as follows:

- For a single SCPI command: Type or copy the desired command in the Telnet editor window, and then press ENTER to execute it.

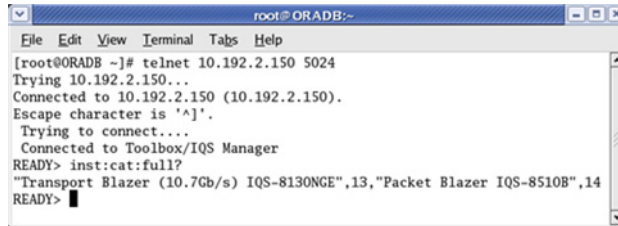

```
root@ORADB:~# telnet 10.192.2.150 5024
Trying 10.192.2.150...
Connected to 10.192.2.150 (10.192.2.150).
Escape character is '^'.
Trying to connect...
Connected to Toolbox/IQS Manager
READY> inst:cat:full?
"Transport Blazer (10.7Gb/s) IQS-8130NGE",13,"Packet Blazer IQS-8510B",14
READY>
```

- For multiple SCPI commands: Copy the desired commands from any script file, enclose them in a BEGIN and END block in the Telnet editor window, and then press ENTER. For more information, see *Internal Commands of the TCP/IP over Telnet Protocol* on page 427.

Note: *Multiple commands that are not enclosed in BEGIN...END blocks will be executed, but problems may occur (results of one command mixed with the results of another one, skipped commands, etc.).*

Once at least one valid command is executed, the module is blocked for any other sessions until the module is released. For more information, see *Releasing Modules* on page 426.

4. Click  to close the session.

Releasing Modules

A module is blocked as soon as a connection is established from any user session executing the internal command `CONNECT LINS`, or a valid instrument (SCPI) command.

For example, when the SCPI command `LINS10:SOURce:DATA:TELEcom:CLEAr` command is executed for the first time by client session 10.192.2.155:1364, the module is blocked for any other client/session until you release it.

A module is released by one of the following actions:

- Executing the `CLOSE LINS` command to disconnect the link with the module. For more information, see *CLOSE LINS* on page 430.
- Executing the `CLOSE` command to end the current session once the execution of all the desired commands has been completed. For more information, see *CLOSE* on page 429.
- Closing the current session by clicking the Close button on the Telnet editor windows' title bar.
- Shutting down and restarting the client computer.
- A network interruption.

A module can also be released when you terminate the communication by using the `KILL LINS` command. For more information, see *KILL LINS* on page 432.

Internal Commands of the TCP/IP over Telnet Protocol

The internal commands allow you to perform certain actions such as send SCPI commands as a script instead of one by one, force the disconnection of an active session, view the status of modules and of connected clients, etc. The internal commands are not case-sensitive.

By default, log files are generated both for client and server (all logs are kept on your unit). You can delete them with the CLEAR LOGS command (see *CLEAR LOGS* on page 429), or manually via the file explorer. The client and sever logs are kept respectively in the *C:\ProgramData\EXFO\SCPI Over TCP/IP Logs\Client log* and in the *C:\ProgramData\EXFO\SCPI Over TCP/IP Logs\Server log* folders.

ABORT BEGIN

Syntax: ABORT BEGIN

The ABORT BEGIN command stops the execution of the SCPI commands that are enclosed in a BEGIN and END block, and returns to the READY> prompt in the Telnet editor window.

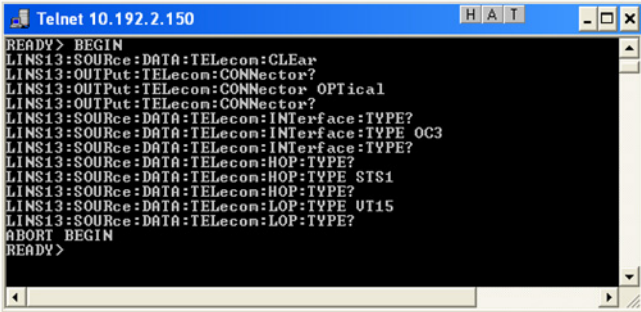

```
Telnet 10.192.2.150  H A T  _ _ X
READY> BEGIN
LINS13:SOURce:DATA:TELecon:CLear
LINS13:OUTPut:TELecon:CONNector?
LINS13:OUTPut:TELecon:CONNector OPTical
LINS13:OUTPut:TELecon:CONNector?
LINS13:SOURce:DATA:TELecon:INTerFace:TYPE?
LINS13:SOURce:DATA:TELecon:INTerFace:TYPE OC3
LINS13:SOURce:DATA:TELecon:INTerFace:TYPE?
LINS13:SOURce:DATA:TELecon:HOP:TYPE?
LINS13:SOURce:DATA:TELecon:HOP:TYPE STS1
LINS13:SOURce:DATA:TELecon:HOP:TYPE?
LINS13:SOURce:DATA:TELecon:LOP:TYPE UT15
LINS13:SOURce:DATA:TELecon:LOP:TYPE?
^B
ABORT BEGIN
READY>
```

Communicating Through TCP/IP over Telnet

Internal Commands of the TCP/IP over Telnet Protocol

BEGIN and END

To execute multiple SCPI commands, you must enclose them in BEGIN and END blocks in a Telnet editor window.

Note: *To execute a single command, simply type or paste the command in the Telnet editor window.*

Note: *You cannot enclose internal commands in a BEGIN and END block, except the ABORT BEGIN command.*

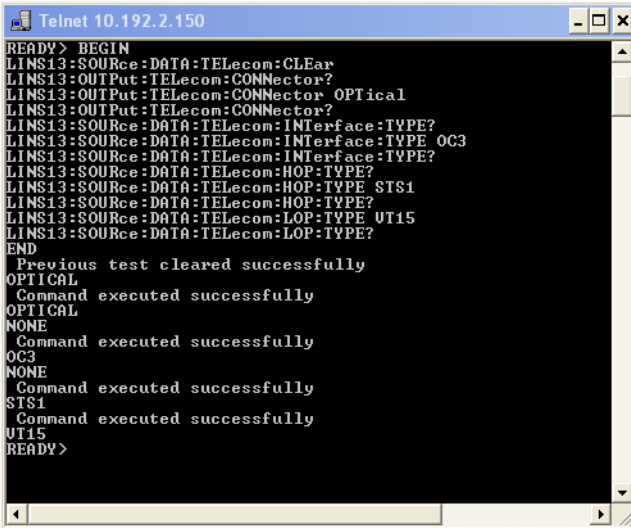

```
Telnet 10.192.2.150
READY> BEGIN
LINS13:SOURce:DATA:TELEcom:CLEAr
LINS13:OUTPut:TELEcom:CONNector?
LINS13:OUTPut:TELEcom:CONNector OPTical
LINS13:OUTPut:TELEcom:CONNector?
LINS13:SOURce:DATA:TELEcom:INterface:TYPE?
LINS13:SOURce:DATA:TELEcom:INterface:TYPE OC3
LINS13:SOURce:DATA:TELEcom:INterface:TYPE?
LINS13:SOURce:DATA:TELEcom:HOP:TYPE?
LINS13:SOURce:DATA:TELEcom:HOP:TYPE STS1
LINS13:SOURce:DATA:TELEcom:HOP:TYPE?
LINS13:SOURce:DATA:TELEcom:LOP:TYPE UT15
LINS13:SOURce:DATA:TELEcom:LOP:TYPE?
END
Previous test cleared successfully
OPTICAL
Command executed successfully
OPTICAL
NONE
Command executed successfully
OC3
NONE
Command executed successfully
STS1
Command executed successfully
UT15
READY>
```

CLEAR LOGS

Syntax: CLEAR LOGS

This command clears all the client and server log files that are older than 36 hours (default value) from the time you execute the command.

```
Trying to connect...
Connected to Toolbox/IOS Manager.
READY> clear logs
Clearing log files older then 1 hours was not success
READY>
```

Note: You can also delete the logs manually via the file explorer. The client and sever logs are kept respectively in the C:\ProgramData\EXFO\SCPI Over TCPIP Logs\Client log and in the C:\ProgramData\EXFO\SCPI Over TCPIP Logs\Server log folders.

CLOSE

Syntax: CLOSE

The CLOSE command terminates the current Telnet session.

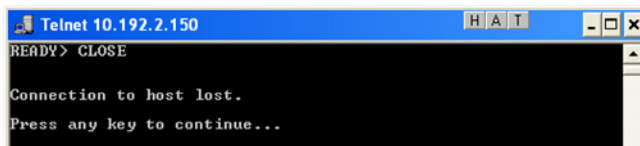

```
Telnet 10.192.2.150 H A T
READY> CLOSE
Connection to host lost.
Press any key to continue...
```

Communicating Through TCP/IP over Telnet

Internal Commands of the TCP/IP over Telnet Protocol

CLOSE LINS

Syntax: CLOSE LINS<Unit_Number> <Module_Slot_Number>

You must specify the unit number and the slot number identifying the module for which you want to close the connections.

This command allows to close active connections. You can send this command to close all client's connections with any module, including the current connection.

If the command is not executed successfully, the possible reasons could be:

- The module is not present at the specified position.
- The provided information does not correspond to a valid LINS.

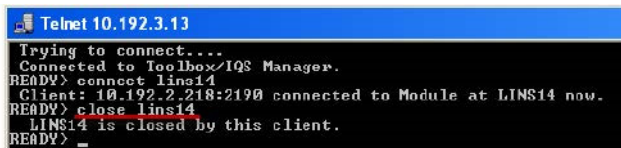

```
Telnet 10.192.3.13
Trying to connect...
Connected to Toolbox/IQS Manager.
READY> connect line14
Client: 10.192.2.218:2190 connected to Module at LINS14 now.
READY> close lins14
LINS14 is closed by this client.
READY> _
```

CONNECT LINS

Syntax: `CONNECT LINS<Unit_Number><Module_Slot_Number>`

You must specify the unit number and the slot number identifying the module to which the session will connect.

This command allows to connect to different modules through TCP/IP. You can connect to multiple modules from a single session.

If the command is not executed successfully, the possible reasons could be:

- The module is already connected to a different client session.
- The module is not present at the specified position.
- The provided information does not correspond to a valid LINS.



```
Telnet 10.192.3.13
Trying to connect...
Connected to Toolbox/IGS Manager.
READY> connect lins14
Client: 10.192.2.218:2190 connected to Module at LINS14 now.
READY> _
```

Note: *For backward compatibility reasons, to connect to a single module, you do not have to use the `CONNECT LINS` command. A valid instrument command (for example, `Lins10:SOURce:DATA:TELEcom:CLEar`) for a valid LINS position will work for a first module. However, you will need to use the `CONNECT LINS` command if you want to connect to other modules as well.*

Communicating Through TCP/IP over Telnet

Internal Commands of the TCP/IP over Telnet Protocol

KILL LINS

Syntax: KILL LINS<Unit_Number><Module_Slot_Number>

You must specify the unit number and the slot number identifying the module for which you want to terminate the session.

This command allows any user to terminate the session that contains the specified connection (LINS). This means it will terminate all active connections that belongs to a session.

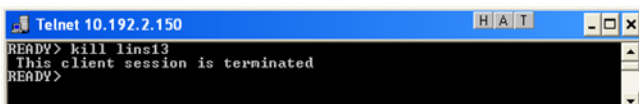

```
Telnet 10.192.2.150 H A T
READY> kill lins13
This client session is terminated
READY>
```

To know the status of the modules before terminating connections using the KILL LINS command, you can first enter the STATUS CLIENT command. For more information, see *STATUS CLIENT* on page 433.

In the example below, two modules are connected: LINS13 and LINS10.

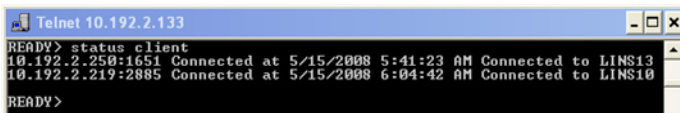

```
Telnet 10.192.2.133
READY> status client
10.192.2.250:1651 Connected at 5/15/2008 5:41:23 AM Connected to LINS13
10.192.2.219:2885 Connected at 5/15/2008 6:04:42 AM Connected to LINS10
READY>
```

To disconnect the LINS10 module used by another session, enter the *kill lins10* command. The **This client session is terminated** message is displayed once the module is disconnected.

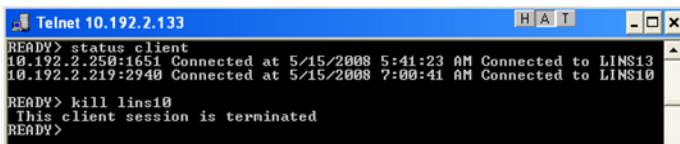

```
Telnet 10.192.2.133 H A T
READY> status client
10.192.2.250:1651 Connected at 5/15/2008 5:41:23 AM Connected to LINS13
10.192.2.219:2940 Connected at 5/15/2008 7:00:41 AM Connected to LINS10
READY> kill lins10
This client session is terminated
READY>
```

Communicating Through TCP/IP over Telnet

Internal Commands of the TCP/IP over Telnet Protocol

Enter again the STATUS CLIENT command to confirm the termination of the module (LINS10 in our example). Only the information of the remaining connected client is displayed.

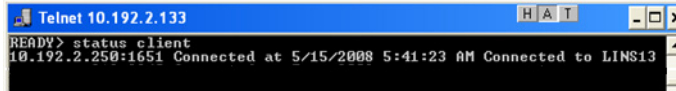

```
Telnet 10.192.2.133  H A T  - _ x
READY> status client
10.192.2.250:1651 Connected at 5/15/2008 5:41:23 AM Connected to LINS13
```

STATUS CLIENT

Syntax: STATUS CLIENT

This command lists out all clients with their connection time and modules.

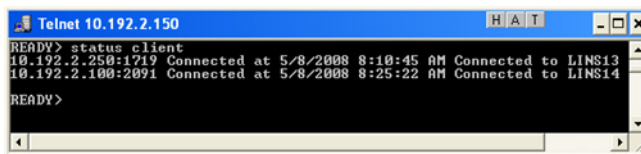

```
Telnet 10.192.2.150  H A T  - _ x
READY> status client
10.192.2.250:1719 Connected at 5/8/2008 8:10:45 AM Connected to LINS13
10.192.2.100:2091 Connected at 5/8/2008 8:25:22 AM Connected to LINS14
READY>
```

STATUS CONNECTION

Syntax: STATUS CONNECTION

This command lists out all the connections with their *Idle* or *Active* status.

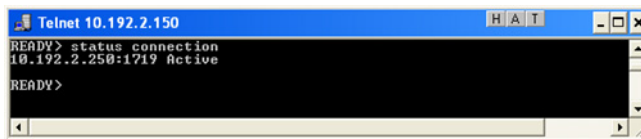

```
Telnet 10.192.2.150  H A T  - _ x
READY> status connection
10.192.2.250:1719 Active
READY>
```

Note: *If any connection is idle for a certain period (5 minutes by default), the service automatically changes the status to Idle.*

Communicating Through TCP/IP over Telnet

Internal Commands of the TCP/IP over Telnet Protocol

STATUS MODULE

Syntax: STATUS MODULE

This command lists out all the modules with the slot numbers where they are located.

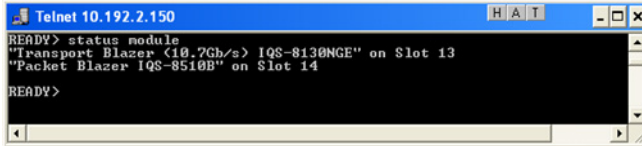

```
Telnet 10.192.2.150
READY> status module
"Transport Blazer (10.7Gb/s) IQS-8130NGE" on Slot 13
"Packet Blazer IQS-8510B" on Slot 14
READY>
```

WHO M I?

Syntax: WHO M I?

This command retrieves the IP address and the communication port of the current session.

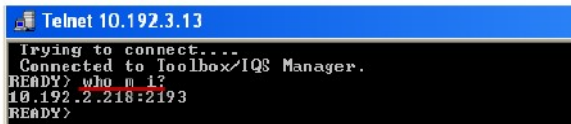

```
Telnet 10.192.3.13
Trying to connect...
Connected to Toolbox/IQS Manager.
READY> who m i?
10.192.2.218:2193
READY>
```

Index

2.0 USB port.....	3, 5
3.0 USB port.....	3
3G USB modem, using	133

A

AC power	
adapter.....	12
connector	4
AC requirements	25
accessing	
Internet with a 3G USB modem	133
online help.....	313
power meter and VFL	145
ToolBox X	57
activating on-screen keyboard	59
ActiveX	
control.....	214
linking units.....	215
selecting	219
adapter	24
adjusting	
brightness.....	77
date, time and time zone.....	111
right-click.....	86
volume.....	78
after-sales service	314
amber LED.....	10
angled brackets.....	258
anti-theft mechanism.....	4, 72
antivirus software.....	71
appearance, date and time	109
applications	
installing.....	63
module, starting	58
ToolBox X, starting	144
ASCII format.....	217

automatic	
fan speed	14
Windows updates	286
automation.....	213

B

backlight, setting.....	77
battery.....	12
error.....	10
LED	2
level	271
maintenance recommendations.....	271
replacing or removing.....	274
type allowed	274
bay	
module	3
power meter	281
black LED.....	10
blinking LED	10
Bluetooth	
data transfer	151
devices	75
frequency band data.....	x
limitations.....	151
option	15
boot, first	55
braces.....	258
brackets	
angled.....	258
square.....	257
brightness, adjusting	77, 127
browsing Web	132
buttons.....	12

C

calibrating the touchscreen	83
capacitors	23
capacity, storage	150

Index

capturing images	2, 131
carry strap, installing	33
caution	
of personal hazard	17
of product hazard	17
certification information	viii
changing	
batteries	274
communication settings	218
date and time	111
language	98
charge icon	271
charger	24
Charm bar, display	60
choosing	
language	98
power management option	112
time zone	111
cleaning	
detector ports	268
front panel	267
touchscreen	270
VFL connectors	269
cleanup disk	168
close window	60
codes, error	262
colon	258
colors, LEDs	10
COM, local control	214
COM/DCOM	
events	416
properties	409
comma	259
commands	
IEEE 488.2	352
SCPI	256
specific	373
TCP/IP	427–433
communication	
ActiveX	214
changing settings	218
default settings	221
Ethernet TCP/IP	213, 214
RS-232	213, 214
TCP/IP over Telnet	214, 417–420
configuring	
power management options	112
unit	55
connecting	
screen	5
to a VPN	176
unit to wireless network	160
USB device	73
connector cleaner	269
ConnectorMax2	147
consulting PDF files	130
control	
ActiveX	214
Ethernet TCP/IP	213, 214
remote	213
RS-232	214
TCP/IP over Telnet	214
controlling modules	213
conventions, programming	256, 259, 261
conventions, safety	17
copying	
commands into text document	264, 266
files and folders	150
creating PDF files	129
current modules view	58
current, electrical	25
customer service	325
D	
data	
transfer	151
types	329
data input	
IEEE 488.2	330
SCPI	349
data output IEEE 488.2	
special	342, 350
standard	339

-
- date and time
 - adjusting 111
 - formats 109
 - DCOM
 - configuring computers 222
 - technology 214
 - deactivating Wi-Fi 172
 - deleting
 - files and folders 150
 - unused system files 168
 - description, function buttons 12
 - detecting module 44
 - detector port, cleaning 268
 - digit 257
 - dirty fibers 147
 - Disk Cleanup 168
 - disk space, free 150
 - display Charm bar 60
 - DisplayPort interface 5
 - documentation 313
 - documents, printing 129
 - dongle, 3G USB 133
 - down, swipe 60
- E**
- earth ground terminal 4
 - enabling wireless device 172
 - equipment returns 325
 - error messages in remote control 262
 - Ethernet port 3
 - Ethernet TCP/IP
 - control 213, 214
 - port 215
 - exiting ToolBox X 57
 - Explorer, Internet 132
 - exporting results 212
 - external power supply 24
- F**
- fan speed 14
 - fiber probe 147
 - file
 - format 212
 - name 212
 - size limit, Bluetooth 151
 - files and folders, managing 150
 - first startup 55
 - flashing LED 10
 - free disk space 150
 - freeing disk space 168
 - frequency, Bluetooth and Wi-Fi x
 - front panel, cleaning 267
 - function buttons description 12
- G**
- gestures, touchscreen 60
 - green LED 10
 - grounding stud 4, 27
- H**
- hazard, laser radiation 21
 - headset
 - Bluetooth 75
 - port 5
 - volume 78
 - help, online 313
 - hibernation mode 49
 - host ports, USB 3
 - hour, setting 111
- I**
- icon, battery 271
 - identification label 314
 - identifying defects on fibers 147
 - IEEE 488.2 commands 352
 - indoor use 23
 - input
 - current 25
 - IEEE 488.2 data types 330
 - SCPI data types 349

Index

inserting
 batteries 274
 module 3, 4, 39
inspection probe 147
installing
 software 63
 third-party software 71
 unit 23
 VPN clients 176
instrument control settings 218
interface, changing language 98
Internet connection 132, 133

K

Kensington lock 4, 72
keyboard
 button 12
 on-screen 59
 USB 73
keywords, SCPI 258

L

label, identification 314
LAN network 214
language, selecting 98
laser safety information 21
launching probe application 147
LED
 battery 2
 indicators 10
left, swipe 60
level, battery 271
linking units
 Ethernet port 215
 via Bluetooth 75
list separator 258
local control 214, 219
lock mechanism 72

M

maintenance
 battery 271
 detector ports 268
 front panel 267
 general information 267
 touchscreen 270
managing files and folders 150
mandatory commands 352
manuals 313
maximum
 distance, Bluetooth 151
 file size 151
 input current 25
mechanical connector cleaning 269
microphone
 port 5
 volume 78
mnemonic, definition 258
modifying power plans 112
module
 controlling 213
 detection 44
 insertion 39
 removal 39
modules
 adapter 3
 slot 3
monitor, external 5
monitoring remote commands 263
mouse
 Bluetooth 75
 USB 73
moving files and folders 150
multiple capabilities 257

N

navigating the Internet 132
network, LAN/WAN 3, 214

- O**
- off LED 10
 - on/off button 2
 - online help 313
 - on-screen keyboard 2, 59
 - opening user guides 130
 - operating system 60
 - operation language 98
 - options
 - Bluetooth 75, 151
 - power meter and VFL 3, 145
 - shoulder strap 33
 - software 15, 66
 - ToolBox X 122
 - Wi-Fi 160
 - orange LED 10
 - output IEEE 488.2
 - special 342, 350
 - standard 339
- P**
- PACKed format 217
 - parameters
 - for ping 207
 - for trace route 210
 - PDF files
 - generating 129
 - viewing 130
 - PDF reader 130
 - physical keyboard 73
 - ping, performing a test 207
 - pipe character 258
 - platform commands 373
 - port
 - Ethernet 3, 215
 - USB 3, 5
 - power
 - sources 12, 25
 - supply 24
 - power management, configuring 112
 - power meter
 - accessing 145
 - location 3
 - power plans, selecting and modifying 112
 - press and hold 62
 - printer, Bluetooth 75
 - printing documents 129
 - product
 - identification label 314
 - specifications 327
 - profiles, Bluetooth 75
 - program switcher button 12
 - programmable instruments,
 - standards 213, 256
 - protective cap 268
 - purchased options 66
- R**
- radiation hazard, laser 21
 - reading PDF files 130
 - real keyboard 73
 - receiving data
 - via Bluetooth 151
 - with Ethernet port 215
 - red LED 10
 - regional and language settings 55
 - register
 - diagram 254, 255
 - ESE 252
 - ESR 252
 - SRE 252
 - STB 252
 - remaining disk space 150
 - remote control
 - ActiveX (DCOM) 214, 215
 - configuring 219, 222, 419
 - description of commands 256
 - error messages 262
 - methods 213
 - monitoring 263

Index

- RS-232 213, 214
- TCP/IP 214, 417–433
- removing
 - batteries 274
 - module 39
 - shoulder strap 33
- repairing unit 23
- return merchandise authorization (RMA) .. 325
- reverting to default settings 221
- right, swipe 60
- right-clicking with touchscreen 62, 86
- RJ-45 port 3
- RS-232
 - communication 213
 - control 214
 - selecting 219
- rules
 - programming 261
 - syntax 259
 - syntax conventions 256

S

- safety
 - caution 17
 - conventions 17
 - information 21
 - warning 17
- saving test results 212
- SCPI
 - commands 256
 - data types 349
 - guidelines 213, 256
- screen
 - captures 2, 12, 131
 - external 5
- securing unit 72
- selecting
 - language 98
 - startup applications 94
 - time zone 111
- semicolon 259

- sending data
 - via Bluetooth 151
 - with Ethernet port 215
- separator 258, 259
- service and repairs 325
- service centers 326
- service request enable register (SRE) 252
- setting
 - date and time 109, 111
 - instrument control utility 218
- sharing data 75
- shipping to EXFO 325
- short and long formats, date 109
- shoulder strap, installing 33
- show Charm bar 60
- shutdown modes 49
- sleep mode 49
- software
 - accessing 57
 - exiting 57
 - installing 63
 - options 15, 66
 - upgrading 63
- space 257
- speaker volume 78, 127
- specific commands 373
- specifications, product 327
- speed of right-click 86
- square brackets 257
- stand for unit 29
- standard event status
 - enable register (ESE) 252
 - register (ESR) 252
- standard status data structure
 - diagram 254, 255
 - general 252
- starting
 - applications 58, 144
 - probe application 147
 - ToolBox X 57
 - Wi-Fi module 172
- startup, selecting applications for 94

- status byte register (STB)..... 252
 - stopping Wi-Fi device..... 172
 - storage requirements..... 267
 - stud, grounding..... 27
 - stylus..... 5
 - support for unit..... 29
 - surfing the Internet..... 132
 - swipe..... 60
 - symbols, safety..... 17
 - syntax
 - rules..... 256, 259
 - SCPI..... 256
 - symbols..... 257
- T**
- TCP/IP
 - activating..... 419
 - commands..... 427–433
 - configuring parameters..... 220
 - connecting to Linux..... 424
 - connecting to Windows..... 420
 - control..... 213, 214
 - features..... 418
 - introduction..... 417
 - port number 5024..... 417
 - release examples..... 426
 - selecting..... 219, 420
 - technical specifications..... 327
 - technical support..... 314
 - telecom ground..... 4
 - temperature for storage..... 267
 - third-party software..... 71
 - time zone, selecting..... 111
 - ToolBox X
 - applications..... 144
 - language..... 98
 - options..... 122
 - touchscreen
 - calibrating..... 83
 - cleaning..... 270
 - gestures..... 60
 - location..... 2
 - right-clicking..... 62
 - stylus..... 5
 - trace route, performing a test..... 210
 - transferring data via Bluetooth..... 151
 - transportation requirements..... 267, 322
 - turning off
 - unit..... 49
 - Wi-Fi..... 172
 - types, data..... 329
- U**
- unit
 - back support..... 29
 - first configuration..... 55
 - installing..... 23
 - repairing..... 23
 - ventilation..... 23
 - updating
 - applications..... 63
 - Windows applications..... 286
 - upgrading software..... 63
 - USB
 - device..... 73
 - ports..... 3, 5
 - user guides..... 313
 - using
 - a 3G USB modem..... 133
 - Bluetooth devices..... 75
- V**
- ventilation..... 23
 - vertical bar..... 258
 - VFL
 - accessing..... 145
 - cleaning..... 269
 - option..... 3
 - viewing
 - current modules..... 58
 - PDF files..... 130
 - virtual private network (VPN)..... 176

Index

W

WAN network.....	214
warranty	
certification	324
exclusions	324
general	323
liability.....	324
null and void.....	323
Web browser.....	132
white space	257
Wi-Fi	
connecting.....	160
frequency band data	x
option.....	15
Windows	
8.1 Pro version.....	60
Embedded 8 Standard version.....	60
update of applications.....	286
Windows Mobility Center.....	127
Windows.old folder.....	168
wireless	
connection.....	133
internal device	172
mouse and keyboard	75
network.....	160
printer	75
wizard, configuration.....	55
working with Windows	60
wsp	257

Y

yellow LED.....	10
-----------------	----

NOTICE

通告

CHINESE REGULATION ON RESTRICTION OF HAZARDOUS SUBSTANCES

中国关于有害物质限制的规定

NAMES AND CONTENTS OF THE TOXIC OR HAZARDOUS SUBSTANCES OR ELEMENTS

CONTAINED IN THIS EXFO PRODUCT

包含在本 EXFO 产品中的有毒有害物质或元素的名称和含量



O	Indicates that this toxic or hazardous substance contained in all of the homogeneous materials for this part is below the limit requirement in SJ/T11363-2006 表示该有毒有害物质在该部件所有均质材料中的含量均在 SJ/T11363-2006 标准规定的限量要求以下。
X	Indicates that this toxic or hazardous substance contained in at least one of the homogeneous materials used for this part is above the limit requirement in SJ/T11363-2006 表示该有毒有害物质至少在该部件的某一均质材料中的含量超出 SJ/T11363-2006 标准规定的限量要求。

Part Name 部件名称	Toxic or hazardous Substances and Elements 有毒有害物质和元素					
	Lead 铅 (Pb)	Mercury 汞 (Hg)	Cadmium 镉 (Cd)	Hexavalent Chromium 六价铬 (Cr VI)	Polybrominated biphenyls 多溴联苯 (PBB)	Polybrominated diphenyl ethers 多溴二苯醚 (PBDE)
Enclosure 外壳	O	O	O	O	O	O
Electronic and electrical sub-assembly 电子和电子组件	X	O	X	O	X	X
Optical sub-assembly ^a 光学组件 ^a	X	O	O	O	O	O
Mechanical sub-assembly ^a 机械组件 ^a	O	O	O	O	O	O

a. If applicable.
如果适用。

MARKING REQUIREMENTS

标注要求

Product 产品	Environmental protection use period (years) 环境保护使用期限 (年)	Logo 标志
This EXFO product 本 EXFO 产品	10	
Battery ^a 电池 ^a	5	

- a. If applicable.
 如果适用。

P/N: 1068733

www.EXFO.com · info@exfo.com

CORPORATE HEADQUARTERS	400 Godin Avenue	Quebec (Quebec) G1M 2K2 CANADA Tel.: 1 418 683-0211 · Fax: 1 418 683-2170
EXFO AMERICA	3400 Waterview Parkway Suite 100	Richardson, TX 75080 USA Tel.: 1 972-761-9271 · Fax: 1 972-761-9067
EXFO EUROPE	Winchester House, School Lane	Chandlers Ford, Hampshire S053 4DG ENGLAND Tel.: +44 2380 246 800 · Fax: +44 2380 246 801
EXFO ASIA-PACIFIC	62 Ubi Road 1, #09-01/02 Oxley Bizhub 2	SINGAPORE 408734 Tel.: +65 6333 8241 · Fax: +65 6333 8242
EXFO CHINA	Beijing Global Trade Center, Tower C, Room 1207, 36 North Third Ring Road East, Dongcheng District	Beijing 100013 P. R. CHINA Tel.: +86 (10) 5825 7755 · Fax: +86 (10) 5825 7722
EXFO SERVICE ASSURANCE	270 Billerica Road	Chelmsford MA, 01824 USA Tel.: 1 978 367-5600 · Fax: 1 978 367-5700
EXFO FINLAND	Elektroniikkatie 2	FI-90590 Oulu, FINLAND Tel.: +358 (0) 403 010 300 · Fax: +358 (0) 8 564 5203
TOLL-FREE	(USA and Canada)	1 800 663-3936

© 2015 EXFO Inc. All rights reserved.
Printed in Canada (2015-11)

